

**BLACK HOLES
IN
COSMOLOGICAL BACKGROUNDS**

*A thesis
submitted for the degree of
Doctor of Philosophy
in the Faculty of Science
University of Calicut, India*

B. S. Ramachandra

**Indian Institute of Astrophysics
Bangalore, India**

March 2003

**BLACK HOLES
IN
COSMOLOGICAL BACKGROUNDS**

*A thesis
submitted for the degree of
Doctor of Philosophy
in the Faculty of Science
University of Calicut, India*

B. S. Ramachandra

**Indian Institute of Astrophysics
Bangalore, India**

March 2003

Dr B. R. S. Babu
Professor

Department of Physics
University of Calicut

Certificate

This is to certify that the thesis entitled '*Black Holes in Cosmological Backgrounds*' is a bona fide record of research work carried out by *B. S. Ramachandra* at the Indian Institute of Astrophysics under my supervision for the award of the degree of Doctor of Philosophy of the University of Calicut and that no part of this thesis has been presented elsewhere for the award of any degree, diploma or other similar title.

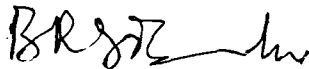

(B. R. S. Babu)

University of Calicut
Calicut, India

Date: 2-04-2003

**BLACK HOLES
IN
COSMOLOGICAL BACKGROUNDS**

*A thesis
submitted for the degree of
Doctor of Philosophy
in the Faculty of Science
University of Calicut, India*

B. S. Ramachandra

**Indian Institute of Astrophysics
Bangalore, India**

March 2003

Declaration

I hereby declare that this thesis entitled '*Black Holes in Cosmological Backgrounds*', submitted to the University of Calicut for the award of a Ph.D. degree, is a bona fide record of the research work carried out by me at the Indian Institute of Astrophysics, Bangalore (a recognised Research Center of the University of Calicut). No part of this thesis has been presented before for the award of any degree, diploma or other similar title.



B. S. Ramachandra

Indian Institute of Astrophysics
Bangalore, India

Date: 29-3-2003

**BLACK HOLES
IN
COSMOLOGICAL BACKGROUNDS**

*A thesis
submitted for the degree of
Doctor of Philosophy
in the Faculty of Science
University of Calicut, India*

B. S. Ramachandra

**Indian Institute of Astrophysics
Bangalore, India**

March 2003

Acknowledgments

Now that the thesis is done, there remains the pleasant task of acknowledging the various persons who have been a source of support, directly or indirectly, through this stage of my research career culminating in the present thesis.

I owe a deep debt of gratitude to my thesis advisor Prof C V Vishveshwara, Indian Institute of Astrophysics (IIA), who initiated and guided me patiently to perform the transition from the crude beginnings of the first steps of research to my 'ripening of the parts'. The accompanying scientific, intellectual, moral and human values imbibed by me during close interaction with him, in a spirit of free inquiry, have been inestimable.

My sincere gratitude goes to Prof B R S Babu, my thesis advisor at Calicut University. I acknowledge the instructive comments of Prof Babu regarding enhancing the readability of the thesis, in particular and on research, in general.

I am grateful once again to Prof B R S Babu and Prof K Neelakandan, Professor and Head, Department of Physics, Calicut University for sustained help and guidance regarding my registration at the University and the associated formalities. I thank Prof S S Hasan, Chairman, Board of Graduate Studies, (IIA) for his valuable guidance and advice regarding the same. My thanks are also due to Mangala Sharma for spear-heading the registration process.

I thank Prof R Cowsik, the Director, IIA, for giving me the opportunity to pursue graduate studies and work towards the PhD degree.

I thank Prof Bala Iyer at the Raman Research Institute (RRI) for his concern, support and advice on numerous occasions. In addition, I am indebted to him for providing me access to the computer centre at RRI and thus enabling me to finish my thesis in time.

I am grateful to Prof Joseph Samuel and Prof Madhavan Varadarajan for discussions at the GRIM meetings and for inviting me to the discussion groups and conferences at RRI.

I thank Prof C Sivaram (IIA) for instructive discussions especially during my course work.

I thank K Rajesh Nayak for numerous discussions, friendly interactions and travels during his stay at IIA.

I am indebted to Dr A Vagiswari, the Librarian, IIA for graciously extending to me the facilities of not only the IIA library but also that of RRI, the Indian Institute of Science (IISc) and the TIFR centre, Bangalore. I acknowledge also, the help rendered to me by the library staff including Mrs Christina Louis, Mr Venkatesh, Mr Yarappa and Mr Prabhakara.

It is with gratitude that I acknowledge the out of the way help that our 'telephone' Shankar (IIA) has been continually rendering to me ranging from enabling communications with Calicut University, to other local concerns.

I am grateful to Mrs Girija Srinivasan, the Librarian at the RRI library for extending to me the facilities of the library and especially, in allowing me to borrow books from the library.

I thank also, Mr A Ratnakar, the former Head Librarian, (RRI). I thank the present Head Librarian Mr Y M Patil for continuing to extend to me the same facilities. To them I must add Mr M N Nagaraj, Mr M Manjunath, Mrs Geetha Sheshadri, Mrs Vrinda Benegal, Mr Hanumappa and Mr Chowdappa.

I thank Mr G Manjunatha, the Secretary, Theoretical Physics division, RRI, for giving me an account at the computer centre thus greatly facilitating my work.

I am grateful to Mrs Meena Srinivasan and Mrs Vani at the TIFR centre, Bangalore, for extending to me the facilities of the library.

My friends at IIA, R Srikanth, Mangala Sharma and S Rajguru made my stay at IIA eventful. By our discussions ranging from science to literature, we literally had a wonderful time. I thank also all my fellow-students at IIA, especially to Raji, Suresh, Sahu, Reji Mathew, Kathiravan, Maheshwar, and Nagaraju for their friendship.

After the formal and official acknowledgments, now to some informal musings.

It is impossible to adequately acknowledge the instruction and guidance I received, during my engineering days, from Prof J Pasupathy who apart from encouraging me to strengthen my mathematical inclination and the basics of Theoretical Physics and Mathematics, also supported me in various ways like giving me problems to work on and access to the libraries at the Centre for Theoretical Studies(CTS) and IISc, Bangalore. To him my deep gratitude. At CTS, I also benefitted from the lectures and courses of Prof N Mukunda.

My 'survival' in Physics through the stormy days of my engineering career was due, in part, to the indescribably deep and continuing mutual empathy, support, strength and inspiration due to my dear friends and fellow way-farers of the 'Physics-team'- A Anand, Rajesh T and Srivatsa S K. In particular, I would like to acknowledge the significant interactions with Srivatsa which mutually furthered the refinement of the intellect and spirit. To them I must add Sudhir Rao, affectionately known to us as 'the Scholar', Ashwin S S, Nirmalya Barat, Manoj K Samal and fellow-seekers at the 'Pioneer Academy'.

To my dear friend Shrirang Deshingkar, I owe numerous discussions in Relativity, Physics, and culture, in general. Apart from this, I acknowledge his invaluable help and support during critical times. Similar are my feelings regarding my friends at IUCAA, Jatush Seth and Parampreet Singh.

I have no words to thank my dear friend R Srikanth for being such a warm-hearted friend ever ready to put aside his own pressing tasks in order to bail me out of difficulties with the computer. His mastery of over more than twenty foreign languages and knowledge of texts of antiquity has been a source of inspiration to me.

Certain things in life are truly inexpressible as they extend beyond the mundane levels and tend to become deep-rooted. 'Help' is, therefore, not the right term and 'thanks' is but a feeble word to acknowledge the support, strength and inspiration due to my dear fellow intellectual and spiritual way-farer, Pratiti. My gratitude to her will always be too deep for words.

The branches of the intellect derive their nourishment from the mother-soil and thus, it is but needless to emphasize the all-embracing nourishment, support and sustenance derived from my Father, Mother, Aunt, brother Nataraj and sister Aparna.

Along with the above, I acknowledge all the others who perhaps, have escaped my ken, but, nevertheless, have played a role in bringing the present stage of my research career to fruition.

**BLACK HOLES
IN
COSMOLOGICAL BACKGROUNDS**

*A thesis
submitted for the degree of
Doctor of Philosophy
in the Faculty of Science
University of Calicut, India*

B. S. Ramachandra

**Indian Institute of Astrophysics
Bangalore, India**

March 2003

Synopsis

For more than three decades black hole physics has been the focus of extensive investigations. A considerable body of knowledge has been accumulated in course of these studies. Most of these investigations, however, have been directed towards black holes represented by vacuum solutions that are time independent and asymptotically flat. Time independence is characterized by the existence of a timelike Killing vector field and asymptotic flatness implies that the spacetime at large distances from the black hole is Minkowskian. These features namely vacuum exterior, time independence and asymptotic flatness lie at the heart of most conceptual and mathematical work associated with black hole physics. When one wishes to study a totally realistic situation, however, it may be necessary to give up either time independence or asymptotic flatness or both. This would be the case, for instance, when the black hole is surrounded by local mass distributions or is embedded in an external universe. Under such circumstances, one would like to ascertain whether the well known properties of black holes are *retained, modified or radically altered*. Black holes in cosmological backgrounds, or more generally, in non-flat backgrounds form, therefore, an important topic. Very little has been done in this direction. Some of the issues involved here have been outlined in a recent article by Vishveshwara[1]. As discussed in that article, there may be fundamental questions of concepts and definitions involved in this context. Addressing all the pertinent issues in a comprehensive manner would be a formidable task indeed. Nevertheless, considerable insight may be gained by studying specific examples even if they are not entirely realistic. In a series of studies we have been investigating black holes in non-flat backgrounds. In this regard the family of spacetimes derived by Vaidya[2] representing in a way black holes in cosmological backgrounds have been found to be helpful. These metrics, in general, correspond to non-vacuum solutions that represent black holes which are no longer asymptotically flat. One of this represents the Kerr black hole in the background of the Einstein universe and the other the special case namely that of the Schwarzschild black hole in the background of the Einstein universe. These spacetimes contain, as limiting cases, the usual Kerr and the Schwarzschild spacetimes respectively and the Einstein universe. In the present thesis, therefore, for the sake of brevity and because of the specific model employed, we shall use the terms 'cosmological' and 'non-flat' interchangeably for convenience, depending on whether we wish to draw attention to the cosmological nature of the background or to the asymptotically non-flat nature respectively.

Some preliminary work performed before the advent of the present thesis may be noted here. The Schwarzschild black hole in the background of the Einstein universe was investigated by Nayak, MacCallum and Vishveshwara[3]. They constructed a composite static spacetime as an example of a black hole in a non-flat background, which comprises a vacuum Schwarzschild spacetime for the interior of the black hole, across which it is matched on to the spacetime of Vaidya representing a black hole in the Einstein universe; this it-

self, in turn, is matched to the Einstein universe. They called this composite spacetime the 'Vaidya-Einstein-Schwarzschild (VES) spacetime'. They also studied the behaviour of scalar waves in this spacetime.

We may mention here some previous work related to black holes in non-flat backgrounds. For instance, McVittie considered the spacetime corresponding to a mass-particle in an expanding universe[8][9][10]. The metric, at a first glance, seems to admit an event horizon. However it can be shown that the spacetime becomes singular on this surface and the interior is not defined at all. As such this spacetime represents essentially a mass-particle rather than a black hole in an expanding universe. For further properties and problems associated with the work of McVittie, we refer to Sussman[11]. There are also studies in the literature based on the so called 'Swiss-cheese model'. Einstein and Straus[10][12] constructed a model which comprises a cavity enclosing a Schwarzschild vacuum spacetime which includes the black hole; exterior to the cavity is the Friedman cosmological spacetime. The above two models have been employed to study the influence of the cosmological expansion on planetary orbits as has been done, for instance, by Gautreau[13](see also Brauer[14]). This study has been extended to the case of a slowly rotating black hole by Chamorro[15].

In the models mentioned above, the matching is not extended up to the horizon as in the case of the VES spacetime. Also, the background parameter R occurring in the VES spacetime can be varied continuously thereby controlling the influence of the non-flat cosmological background. As R increases, approaching the limit of the Schwarzschild vacuum solution as R tends to infinity. Furthermore, the VES spacetime is a special case of the Kerr black hole in the background of the Einstein universe given by Vaidya. So the study of the VES spacetime is a precursor to that of the Vaidya-Einstein-Kerr (VEK) spacetime. Obviously a study of the VEK spacetime would lead to a greater insight into rotating black holes in non-flat backgrounds.

In the present thesis we study both the VES and the VEK spacetimes. After investigating some physical effects in the VES spacetime we move on to the VEK spacetime focusing on the geometry and physics of the event horizon. This is followed by an investigation of important physical effects in the VEK spacetime. We then move on to discuss the Carter constant and the Petrov classification of the VEK spacetime. Lastly, we study the structure of particle angular momentum in the VEK spacetime. Throughout we compare and contrast the results obtained with that of their flat background counterparts. An detailed outline of the thesis is given below.

1. The Vaidya-Einstein-Schwarzschild black hole: Some physical effects.

In our study of the VES spacetime we have investigated some physical effects such as the classical tests and geodesics[21]. The pertinent results are as follows.

- **The background-black hole decomposition.**

In order to study the effects due to the background and the black hole clearly, we have introduced the background-black hole decomposition. This idea is implicit while expressing the Kerr metric in Kerr-Schild coordinates but has not been exploited fully especially in the case of the Schwarzschild metric. This decomposition enables us to neatly separate out the various geometrical and physical quantities associated with the spacetime into background and black hole quantities. Thus attention may be given to either the background spacetime or the black hole in order to study or generalize the properties of the spacetime. In particular, the background may be extended from a flat into a non-flat one. As an application, we have decomposed the test particle Lagrangian as the sum of a background and a black hole term. The background term may be thought of as a kinetic energy term and the black hole term may be thought of as a potential energy term, in analogy with the usual Lagrangian formalism. This allows us to decompose the conserved quantities into corresponding background and black hole terms as well.

It is expected that the background-black hole decomposition may be carried out in the case of black hole spacetimes other than the Einstein universe facilitating thereby to find new solutions of black holes in non-flat backgrounds, especially in the background of an expanding Universe.

- **The effective potential.**

We have presented the effective potential for particle motion and performed a qualitative analysis by plotting the effective potential against the radial coordinate. We have shown that at small values of the background parameter, the influence of the cosmological background is so large that there is an enormous modification in the nature of the orbits. At large values of the background parameter the orbits tend to their Schwarzschild character as the cosmological influence decreases.

- **The classical tests.**

Our study of the classical tests, namely the gravitational redshift, the perihelion precession and light bending, in the Vaidya sector of the VES spacetime shows how the non-flat nature of the background spacetime affects the Schwarzschild results. The non-flat background manifests itself through the background parameter R . This is more so in the case of the perihelion precession and light bending than in the case of the gravitational redshift.

- **The gravitational redshift.**

In the usual Schwarzschild case we can find the ratio of the frequencies of light emitted at a certain point in the spacetime and observed at another.

In the VES case however, due to the presence of different sectors, the effect becomes much more interesting. We have considered the gravitational redshift seen by a static observer in the Einstein sector due to light emitted in the Vaidya sector. We have shown that when both the observation and the emission points are in the Einstein sector the redshift is absent as is expected.

– **Perihelion precession.**

We have shown that the presence of the background increases the perihelion precession. The perihelion shift has been calculated in full and also to second order in $1/R$.

– **Bending of light.**

We have shown that the presence of the background causes an increase in the bending of light. This effect is analogous to that in perihelion precession. Again, the calculations have been presented in full and to second order in $1/R$.

• **Geodesics in the VES spacetime.**

A study of geodesics is the direct route towards gaining qualitative and quantitative insight into the nature of the spacetime. First we have studied circular geodesics and then presented a brief classification of the geodesics.

• **Circular geodesics.**

In the Schwarzschild case there is a photon orbit at $r = 3M_s$ and timelike orbits exist below this limit. In contrast we have shown that in the VES case, there are two photon orbits and that time-like circular geodesics exist within these two limits. There are no circular geodesics beyond these values. This is analogous to the effect in the Ernst spacetime, where two null circular geodesics are present as has been pointed out by Nayak and Vishveshwara[18]. As the background influence becomes small the inner null circular geodesic approaches the Schwarzschild value $r = 3M_s$ and the outer null circular geodesic approaches infinity. An interesting feature which we have pointed out here is that of the centrifugal force reversal, which has been discussed by Prasanna [19]. The centrifugal force reverses at the inner null circular orbit by becoming inward. This is analogous to what happens in the case of the Schwarzschild spacetime. We have shown that in the present case, such a reversal takes place at the outer null orbit also, as in the case of the Ernst spacetime. Since the Schwarzschild case has a null circular orbit at only $r = 3M_s$, this implies that the effect of the Einstein cosmological background is in bifurcating the null circular orbit of the Schwarzschild spacetime into two thereby completely altering the nature of the Schwarzschild circular geodesics.

- **Classification of the geodesics.**

We have presented a brief classification of the geodesics. In the Schwarzschild spacetime there are eight timelike and three null geodesics. In contrast to this we have shown that the VES spacetime allows eight timelike and eight null geodesics.

2. Geometry of the Vaidya-Einstein-Kerr black hole.

- **The event horizon.**

By studying the event horizon, we have shown that the background gives rise to significant modifications in the geometrical and physical quantities associated with the black hole. The event horizon shrinks from its limiting Kerr magnitude as the background influence increases and the stationary limit surface gets more distorted. Thus there is an enlargement of the ergosphere.

- **The circumferences.**

We have shown that the distortion of the horizon can be ascertained by computing its equatorial and polar circumferences and studying the variation of the oblateness parameter. The oblateness parameter δ is given by the difference of the equatorial and polar circumferences divided by the equatorial circumference. This has been investigated by two different approaches. In the first instance, to compare the results with those obtained by Smarr in the Kerr case, we have varied the distortion parameter without varying the background parameter.

We have shown that further insight can be gained into the structure of the horizon by investigating the oblateness as an explicit function of the parameters a and the background parameter R . As we have pointed out there exist both modulated and direct effects.

The modulated effect is obtained by varying a for different fixed values of R . Here we have found a totally unexpected effect. That is, whereas the equatorial circumference C_e increases monotonically with a for all values of R , the polar circumference C_p first decreases as a increases, starting from the Kerr value, and then increases after a critical value of R . Nevertheless, the oblateness parameter increases with a for all values of R . On the other hand the direct effect is obtained by varying the circumferences with R . Here, one sees that both C_e and C_p decrease as R decreases, ie as the background influence increases. However, the oblateness parameter increases as R decreases.

- **The surface area of the horizon.**

Another quantity that indicates the change in the geometry of the event horizon is its surface area. As was done in the case of the circumferences, we have studied two different effects of the background on the area. First the modulation of rotation by the background and second the direct effect of the background. In the first case, for large values of R the area decreases monotonically with a as in the Kerr case. Then for a critical range of values of R the area increases, attains a maximum and then, decreases. Finally for small values of R it increases monotonically with a . This effect is also a novel one which reveals the peculiarity of the background influence. Next, we have the direct effect of the background. As R decreases thereby enhancing the background effect, the area decreases and asymptotically approaches the Kerr value as the background effect goes down.

Our analysis of the surface area of the VEK black hole has shown that it is no longer a function of the scale parameter η alone as in the Kerr case. It gets coupled to the distortion parameter β as well.

- **The angular velocity of the horizon.**

The angular velocity of the VEK event horizon is an important physical quantity. It plays a central role in physical effects such as superradiance. We have shown that it goes up significantly as the background influence increases.

- **Gaussian curvature and embedding.**

By investigating the intrinsic geometry as represented by the Gaussian curvature we have shown that the VEK black hole may be classified into two distinct classes. The first class consists of black holes with positive Gaussian curvature and the second consists of black holes with negative Gaussian curvature. In the Kerr case studied by Smarr, this classification is on the basis of two constant 'limiting' values of the distortion parameter β . In the VEK case however, the corresponding 'limiting' values are no longer constants but depend on the angular momentum parameter a and the background parameter R . The topology of the VEK event horizon is that of a 2-sphere as may be expected for any normal black hole.

3. Examples of physical effects in the VEK Spacetime.

We have investigated some physical effects in the VEK spacetime. These include circular geodesics and the gyroscopic precession.

- **Circular geodesics.**

A study of the circular geodesics is very fruitful in gaining insight into the nature of the black hole and the spacetime. In the VES case, as mentioned above,

the nature of the geodesics changes significantly due to the non-flat background. In the VEK case we have shown that the changes are more pronounced due to the presence of rotation. In the Kerr spacetime only one null circular geodesic exists. Corresponding to this there is one co-rotating and one counter-rotating orbit. Timelike geodesics exist all the way up to infinity. In contrast, the VEK case allows two different possibilities depending on the background parameter.

In the first case two null circular geodesics are present. There is an inner null geodesic and an outer null geodesic. Each of these have one co-rotating and one counter-rotating orbit. Timelike geodesics exist between the inner and the outer null geodesics.

In the second case only one null geodesic exists. Corresponding to this is one co and one counter-rotating orbit. There is a complete absence of timelike circular geodesics. The impact parameter also reflects this feature as we have shown in the special case of the VES spacetime.

By investigating the phenomena of gyroscopic precession in the VEK spacetime we have shown that the background affects the precession in both modulated and direct effects. The first torsion which in the Kerr case coincided with the Schwarzschild Keplerian frequency now no longer coincides with the VES generalized Keplerian frequency. It is now a function of the angular momentum parameter as well in contrast to the Kerr case. This brings about a pronounced modification of the results from the Kerr case. In particular this gives rise to a generalized version of the Schiff precession. Moreover, even in the special cases of the generalized versions of the Fokker-De Sitter precession in the VES spacetime, the background prevents the first torsion from being equivalent to the generalized Keplerian frequency. Finally, the generalized version of the Thomas precession in the Einstein universe is also considerably modified.

- **The Carter constant and Petrov classification of the VEK spacetime.** A study of the Carter constant and the Petrov classification sheds light on the connection between the properties of the geodesics and the classification of the gravitational field. Thus, starting with a discussion of Carter's discovery of the fourth constant in the Kerr case, we have shown by construction that the Carter constant exists in the VEK spacetime also. From the Carter constant we have obtained the Killing tensor and brought out its significance by considering the special case of the Schwarzschild spacetime wherein the Killing tensor becomes reducible.

Next, taking into account the fact that in the Kerr spacetime, the Killing tensor is related to the Killing-Yano tensor which, in turn, is related to the type-D

nature of the spacetime, we have investigated the classification of the VEK spacetime. By employing the Newman-Penrose formalism we have calculated the spin coefficients for the VEK spacetime. We have shown that unlike the Kerr case there is a non-vanishing spin coefficient ϵ . Even though the rest of the results mirror that in the Kerr case, their expressions are considerably complicated. These spin coefficients contain as limiting cases the Kerr and the VES counterparts and of course the Schwarzschild ones also. The Bianchi identities contain non-zero Ricci terms also in addition to the Weyl scalars.

Motivated by the significance of the type-D nature of a black hole spacetime we have studied the classification of the VEK spacetime. We have demonstrated explicitly and in detail, that the VES spacetime is type-D. We have shown that the only non-vanishing Weyl scalar is Ψ_2 . Turning to the Ricci terms, the only non-zero terms are Φ_{00} , Φ_{11} , Φ_{22} and the scalar Λ . That these terms which vanish in the Schwarzschild case do not do so here shows that the spacetime is non-vacuum. In the Einstein universe also the Ricci terms are non-zero which brings out the asymptotically non-flat nature of the spacetime. The optical scalars ω and σ vanish as in the Schwarzschild case whereas the optical scalar Θ is modified because of the background.

We have discussed the 2-spinor formalism and constructed the Killing spinor for the VEK spacetime. By means of the Killing spinor we have calculated the Killing-Yano tensor and shown that in the limit of the background parameter tending to infinity this coincides with the Killing-Yano tensor of the Kerr spacetime.

- **Geodetic Particle Angular Momentum in the VEK spacetime.**

With the above apparatus in hand, we have investigated the relation between the Killing and the Killing-Yano tensors. The Killing tensor has been shown to be a 'square' of the Killing-Yano tensor. Both these tensors have been expressed through the Newman-Penrose tetrads to further clarify their structure. We have shown that these tensors contain the Kerr counterparts as limiting cases. By constructing a tetrad for the Killing tensor we have further exhibited the relations between the metric, the Killing and the Killing-Yano tensors. The eigenvalues of these tensors have been calculated.

We have introduced the background-black hole decomposition and discussed the Kerr-Schild and the generalized Kerr-Schild transformations and their implications for the Kerr and the VEK cases respectively. By employing this decomposition we have expressed the Newman-Penrose tetrad in terms of background and black hole terms. Further, we have split the Hamiltonian, the four-momentum, and the Killing tensor into background and black hole terms. We have shown

that the Killing-Yano tensor has only a background term.

Focusing on the Killing-Yano tensor we have employed the phase space formalism to project it to space. By means of the projected tensor we have defined quantities analogous to the components of particle angular momentum. These components satisfy the Poisson bracket relations expected of them. We have shown that to first order in the angular momentum parameter and to second order in the inverse of the background parameter, the angular momentum vector precesses along the central axis preserving its magnitude.

To summarize, we have demonstrated that the effect of the background on the properties of the usual black holes are significant. We have shown that the results may be classified into three groups. In the first, the properties of the black holes are *retained*. Such is the case with the gravitational redshift discussed in Chapter 2 and the existence of the Carter constant and the Petrov classification of the VES spacetime discussed in Chapter 5. The results here are similar to that in the flat case. In the second case, the properties of the black holes are considerably *modified*. This is the case with the perihelion precession, the bending of light considered in Chapter 2, the geometry of the ergosphere, the angular velocity, topology, and the nature of the spin coefficients corresponding to the VEK black hole as shown in Chapter 5. In the third case, the properties of the black holes are *radically altered*. This includes the behavior of circular geodesics and the classification of the timelike geodesics in the VES spacetime discussed in Chapter 2, circular geodesics in the VEK spacetime and the nature of gyroscopic precession discussed in Chapter 4.

To conclude, we have shown that the effect of the background on the properties of the usual black holes is clear and patent. As a prototype the Vaidya cosmological-black holes on which we have based our investigations is specific and restricted. Nevertheless, it is not at all unlikely that the above effects may be retained or even enhanced in more realistic models.

**BLACK HOLES
IN
COSMOLOGICAL BACKGROUNDS**

*A thesis
submitted for the degree of
Doctor of Philosophy
in the Faculty of Science
University of Calicut, India*

B. S. Ramachandra

**Indian Institute of Astrophysics
Bangalore, India**

March 2003

Contents

1	Introduction	1
1.1	Black Holes in Cosmological Backgrounds	1
1.2	Motivation	2
1.3	The Issues	5
1.4	Our Approach	6
1.5	Prototypes of Black Holes in Non-Flat Backgrounds	7
1.6	The Vaidya Cosmological-Black Hole Metric	8
1.7	Outline of the Present Investigations	8
2	The Vaidya-Einstein-Schwarzschild Black Hole: some physical effects	9
2.1	Introduction	9
2.2	The Vaidya-Einstein-Schwarzschild (VES) Spacetime	10
2.3	The Background-Black Hole Decomposition	12
2.3.1	The metric	13
2.3.2	The geodesic Lagrangian	16
2.3.3	The decomposed geodesic Lagrangian and conserved quantities	17
2.4	The Classical Tests	19
2.4.1	The gravitational redshift.	19
2.4.2	Perihelion precession	20
2.4.3	Bending of light	20
2.5	Geodesics in the VES spacetime	21
2.5.1	Circular geodesics	21
2.5.2	Geodesics and their classification	23
2.6	Concluding Remarks	25
3	Geometry of the Vaidya-Einstein-Kerr Black Hole	26
3.1	Introduction	26
3.2	The Vaidya-Einstein-Kerr (VEK) Spacetime	27
3.2.1	The Vaidya cosmological-black hole metric	27
3.2.2	VEK metric in the Boyer-Lindquist form	29
3.2.3	The energy-momentum tensor	30
3.2.4	The event horizon and the ergosphere	30
3.3	The Shape of the Event Horizon	34
3.3.1	The approach of Smarr	35

3.4	The Surface Area	42
3.4.1	Effect of the background on the area	42
3.5	Angular Velocity of the Horizon	44
3.6	Surface Gravity and the Extreme VEK Black Hole	45
3.7	The Gaussian Curvature and Embedding	46
3.7.1	Embedding	48
3.8	Concluding Remarks	49
4	Examples of Physical Effects in the VEK spacetime	52
4.1	Introduction	52
4.2	Circular Geodesics	53
4.2.1	The metric	53
4.2.2	The method of Killing vectors	54
4.2.3	The geodesic Lagrangian	56
4.3	Gyroscopic Precession	60
4.3.1	The Frenet-Serret formalism	60
4.4	Gyroscopic Precession Along Timelike Killing Trajectories	61
4.5	Rotating Coordinates and Gyroscopic Precession Along Circular Orbits	63
4.5.1	VES black hole	67
4.5.2	Einstein universe	69
4.6	Concluding Remarks	71
5	The Carter Constant and the Petrov Classification of the VEK Spacetime	72
5.1	Introduction	72
5.2	The Carter Constant	74
5.3	The Killing Tensor	77
5.4	The Spin Coefficients and Petrov Classification	80
5.4.1	The Newman-Penrose formalism	81
5.4.2	The Newman-Penrose null tetrad	82
5.4.3	The spin coefficients	83
5.5	Classification of the VES Spacetime	88
5.6	The Killing Spinor	91
5.6.1	Brief review of the 2-spinor formalism	91
5.6.2	The Killing spinor	94
5.6.3	Killing spinor and the VEK spacetime	96
5.7	The Killing-Yano Tensor	99
5.8	Concluding Remarks	101
6	Geodetic Particle Angular Momentum in the VEK Spacetime	103
6.1	Introduction	103
6.2	The Phase Space Formalism	106
6.3	Relation Between the Killing and the Killing-Yano Tensors	111
6.3.1	Some remarks on the Killing and the Killing-Yano tensors	113

6.3.2	Significance of the Killing-Yano tensor	115
6.4	The Background-Black Hole Decomposition	117
6.5	Particle Angular Momentum	121
6.6	Concluding Remarks	125
7	Conclusion	127
7.1	Summary of Results	127
7.2	Discussion	132

**BLACK HOLES
IN
COSMOLOGICAL BACKGROUNDS**

*A thesis
submitted for the degree of
Doctor of Philosophy
in the Faculty of Science
University of Calicut, India*

B. S. Ramachandra

**Indian Institute of Astrophysics
Bangalore, India**

March 2003

List of Figures

2.1	Plot of the effective potential $V(r)$ for $M = 1, L = 6$	18
3.1	Plots of r_s and r_+ corresponding to the stationary limit and the event horizon respectively for $R = 0.6, 1, 10$ respectively going outwards from the centre. The $R = 10$ plot is almost indistinguishable from the Kerr case(not shown). Here $M = 1, a = 0.5$	32
3.2	Plots of $R \tan(r_s/R)$ (the stationary limit represented by the solid curves), $R \tan(r_+/R)$ (event horizon represented by the dashed curves) for $M = 1, a = 0.5$ and different values of R . The values of R are 0.6(top left),1(top right) and 10(bottom).	33
3.3	This plot shows the behaviour of the distortion parameter β with a for $M = 1$ and for different values of R including the Kerr case.	36
3.4	This plot shows the behaviour of the distortion parameter β with R for $M = 1$ and $a = 0.5$	37
3.5	The equatorial and the polar circumferences plotted against β for different values of R	38
3.6	The oblateness parameter δ plotted against β for both the Kerr and the VEK cases.	38
3.7	Plot of the equatorial circumference C_e against a^{-1} for $M = 1$ and for different values of R . Both the Kerr(left) and the VEK(right) cases are shown.	39
3.8	Plot of the polar circumference C_p against a^{-1} for $M = 1$ and for different values of R . For large values of R including the Kerr case(left), C_p decreases as a^{-1} decreases. After a critical value of R (not shown), C_p increases as a^{-1} decreases(right). Thus C_p is strongly modulated by the background.	39
3.9	Plot of the oblateness parameter δ against a^{-1} for $M = 1$ and for different values of R . Both the Kerr(left) and the VEK(right) cases are shown.	40
3.10	Plot of the equatorial circumference C_e against R for $M = 1, a = 0.5$	41
3.11	Plot of the polar circumference C_p against R for $M = 1, a = 0.5$	41
3.12	Plot of oblateness parameter δ against R for $M = 1, a = 0.5$. This illustrates the direct effect of the background on δ	41
3.13	Plot of the area A against a for $M = 1$, for the Kerr case(top left) and for different values of R in the VEK case. For $R = 1.8$ (top right), A attains a maximum due to strong modulating effect of the background. After a critical range of values of R , the VEK area increases as a increases(bottom).	43
3.14	Plot of the area A against R for $M = 1$ and $a = 0.5$. Both the Kerr and the VEK cases are indicated. The decrease of the VEK area as R decreases, exhibits the direct effect of the background.	44
3.15	Plot of the angular velocity ω_H of the horizon against R for $M = 1, a = 0.5$. As R decreases, ω_H increases due to strong background influence.	45

3.16 The sequence of embedding diagram for $\beta = 0$ (dashed line), $\frac{1}{2}\sqrt{1 + a^2/R^2}$ (dotted line), $\frac{1}{\sqrt{2}}\sqrt{1 + a^2/R^2}$ (solid line) shown for $a = 0.5$ and $R = 1$ 48

**BLACK HOLES
IN
COSMOLOGICAL BACKGROUNDS**

*A thesis
submitted for the degree of
Doctor of Philosophy
in the Faculty of Science
University of Calicut, India*

B. S. Ramachandra

**Indian Institute of Astrophysics
Bangalore, India**

March 2003

Chapter 1

Introduction

1.1 Black Holes in Cosmological Backgrounds

For more than three decades black holes have been investigated in great detail. Most of these studies, however, have been directed towards black holes represented by vacuum solutions that are time independent and asymptotically flat. Time independence is characterized by the existence of a timelike Killing vector field and asymptotic flatness implies that the spacetime at large distances from the black hole is Minkowskian. These features namely vacuum exterior, time independence and asymptotic flatness lie at the heart of most conceptual and mathematical work associated with black hole physics. When one wishes to study a totally realistic situation, however, it may be necessary to give up either time independence or asymptotic flatness or both. This would be the case, for instance, when the black hole is surrounded by local mass distributions or is embedded in an external universe. Under such circumstances, one would like to ascertain whether the well known properties of black holes remain *retained, modified or radically altered*.

Black holes in cosmological backgrounds, or more generally, in non-flat backgrounds form, therefore, an important topic. Very little has been done in this direction. Some of the issues involved here have been outlined in a recent article by Vishveshwara[1]. As discussed in that article, there may be fundamental questions of concepts and definitions involved in this context. Addressing all the pertinent issues in a comprehensive manner would be a formidable task indeed. Nevertheless, considerable insight may be gained by studying specific examples even if they are not entirely realistic. In a series of studies we have been investigating black holes in non-flat backgrounds. In this regard the family of spacetimes derived by Vaidya[2] representing in a way black holes in cosmological backgrounds have been found to be helpful. These metrics, in general, correspond to non-vacuum solutions that represent black holes which are no longer asymptotically flat. One of this represents the Kerr black hole in the background of the Einstein universe and the other the special case of the Schwarzschild black hole in the background of the Einstein universe. These spacetimes contain, as limiting cases, the usual Kerr and the Schwarzschild spacetimes respectively and the Einstein universe. In the present thesis, therefore, for the sake of brevity and because of the specific model employed, we shall use the terms ‘cosmological’ and ‘non-flat’ interchangeably for convenience, depending on whether we wish to draw attention to the cosmological nature of the background or to the asymptotically non-flat

nature respectively.

We may mention some preliminary work performed before the advent of the present thesis. The Schwarzschild black hole in the background of the Einstein universe was investigated by Nayak, MacCallum and Vishveshwara [3]. They constructed a composite static spacetime as an example of a black hole in a non-flat background, which comprises a vacuum Schwarzschild spacetime for the interior of the black hole, across which it is matched on to the spacetime of Vaidya representing a black hole in the Einstein universe; this itself, in turn, is matched to the Einstein universe. They called this composite spacetime the ‘Vaidya-Einstein-Schwarzschild (VES) spacetime’. They also studied the behaviour of scalar waves in this spacetime.

With this as the starting point we shall investigate in this thesis, further properties of black holes in non-flat backgrounds.

The organization of this chapter is as follows. In Section 1.2, we discuss the motivation for our investigations. In Section 1.3, we address some of the issues involved. In Section 1.4, we give an outline of the approach we have taken. In Section 1.5, we consider other possible specific models and discuss the reason for choosing the Vaidya cosmological black hole spacetimes. In Section 1.6, we discuss briefly the Vaidya cosmological-black hole metric. In Section 1.7, we conclude this chapter with a brief outline of the investigations that we have performed.

1.2 Motivation

As mentioned in the Introduction, most investigations on black holes have been directed towards black holes represented by vacuum solutions which are time independent and asymptotically flat. We now discuss the implications of these features briefly.

1. Vacuum (or charged) solutions: This feature is at the base of most of the theorems on black holes. In particular, it is crucial for the formulation of theorems associated with the Petrov classification. For instance, the Goldberg-Sachs theorem rests on the vacuum nature of the Kerr and Schwarzschild spacetimes. Through this theorem, or directly by the nature of the Weyl scalar components, it follows that the vacuum black hole spacetimes are all of Petrov type-D. Another theorem of considerable importance in black hole physics, which assumes a vacuum spacetime, is the Hawking area theorem.
2. Asymptotic flatness: This feature is based on the reasonable assumption that the curvature generated by the source far outweighs the average curvature due to the

rest of the matter in the universe. Thus, it is assumed that the spacetime at large distances from the black hole is Minkowskian. Most of the black holes represented by vacuum solutions satisfy this criterion. Though this feature is present implicitly or explicitly in the formulation of theorems associated with black holes, it is not completely clear whether it is really necessary. Also, asymptotic flatness is invoked in order to identify conserved quantities via Komar integrals.

3. Time independence: The static, spherically symmetric Schwarzschild black hole and the stationary, axisymmetric Kerr black hole are both time independent. Thus, such spacetimes are characterized by the existence of a timelike Killing vector. It is this feature that ensures that one can define the event horizon of the black hole as a Killing horizon. Thus in the absence of this feature it is not clear as to how to define the black hole itself. Moreover, the definition of conserved quantities like the total mass are tied up with the existence of a timelike Killing vector.

We now contrast the above with an example of a totally realistic situation characterized by the following.

1. Non-vacuum: In a situation such as that encountered in astrophysics, for instance, the black hole may be surrounded by local mass distributions. The spacetime around the black hole would then be described by an energy-momentum tensor satisfying certain reasonable energy conditions. Thus the black hole would no longer be represented by a vacuum solution of the Einstein field equations. Thus, for instance, the classification of the spacetime could possibly be affected as there would be no analogue of the Goldberg-Sachs theorem.
2. Embedded in external universe: In a totally realistic situation the black hole would not be surrounded by empty space but by an external universe. Depending on the model chosen to correspond to observational data, there are two possibilities.
 - Static universe: In view of the observational tests suggesting a non-static universe this would seem to be not entirely realistic. However, this choice preserves time independence and ensures the existence of a timelike Killing vector field. Thus the black hole could still be defined by means of a Killing horizon. Such a model although not entirely realistic, affords a simple example for studying black holes in non-flat backgrounds. This would constitute a first step in developing more realistic scenarios.
 - Time dependent(Expanding) universe: Present day observational data is strongly in favour of an expanding universe described by a Friedman-Robertson-Walker spacetime. It is clear that in this case a timelike Killing vector field no longer

exists. Thus it is not possible to define the black hole via a Killing horizon as per the standard methods.

Regarding the above two points, it is clear that in both situations the black hole spacetime would no longer be asymptotically flat but would correspond to the spacetime of the background universe.

From the above discussion we may draw the following conclusions which serve as motivation for our studies.

- The properties of the usual black holes may change when the features of vacuum, asymptotic flatness and time independence are relaxed.
- Since black hole and cosmological spacetimes have been well explored the combination namely black holes in cosmological backgrounds may yield more insight into the properties of spacetimes in general.
- The usual black holes do not admit stationary perturbations that vanish at large distances from the black hole, thereby preserving asymptotic flatness. This means that the black holes cannot be distorted, a fact supported by the uniqueness theorems. Other topics that fall within the scope of perturbation analysis are, the question of stability, the study of propagation and scattering of radiation and the determination of quasinormal modes. It would be interesting and instructive to find out how these phenomena are modified when the background is no longer flat.

The relaxation of the above mentioned features of the usual black holes may give rise to subtle modifications from the standard results. Regarding this we may point out that even in the standard case of the Schwarzschild black hole the introduction of rotation leads to profound changes. For instance, in the static case the timelike Killing vector field becomes null on the event horizon which is at once the static limit and a Killing horizon. On the other hand, in the case of the Kerr black hole the stationary limit at which the corresponding timelike Killing vector field becomes null does not coincide with the event horizon which still remains a null surface. However, a suitable combination of the timelike and rotational Killing vector fields enables us to construct a globally hypersurface orthogonal, irrotational vector field which does become null on the event horizon. The separation of the stationary limit from the event horizon giving rise to the ergoregion in between leads to several interesting phenomena such as the Penrose process and superradiance. Similarly the reverse situation may prevail, namely phenomena that occur in the Schwarzschild spacetime may not take place in the Kerr spacetime. For instance, the generation of

gravitational synchrotron radiation present in the Schwarzschild spacetime is absent in the Kerr spacetime. In a like manner, relaxation of the features of standard black holes may radically transform black hole physics.

We now discuss some of the issues involved.

1.3 The Issues

We give a very brief account of some of the approaches attempted by different authors towards generalization of black holes.

1. Tipler(1977)[4] gave a definition of a black hole as a region containing all non-cosmological trapped surfaces whose boundary is generated by null geodesic segments. Thus in accordance with this, the local properties remain unaltered whereas the global behaviour does change.
2. Joshi and Narlikar(1982)[5] defined a black hole in a globally hyperbolic spacetime to be a future set of all closed compact spacelike 2-surfaces which are either trapped or marginally trapped. Their definition differs from that of Tipler in that it does not distinguish between local and cosmological trapped surfaces and covers all possible local collapse situations. In other words, they defined the black hole on the basis of the trapping of light by the gravitational field of a collapsing object in a globally hyperbolic spacetime.
3. Hayward[6] has defined the black hole as a certain type of trapping horizon. A trapping horizon is a 3-surface foliated by marginal surfaces. And a marginal surface is a spatial 2-surface where a light wave would have instantaneously parallel rays. He classified the marginal surfaces into four types, described as future or past and outer or inner. The future outer trapping horizon provides the definition of a black hole. This also excludes cosmological horizons and is thus closer in spirit to that of Tipler.
4. Ashtekar et al[7] in recent work have introduced the concept of what they call an isolated horizon. Their key idea is to replace the notion of a stationary black hole with that of an isolated horizon, which can be identified with a portion of the event horizon which is in equilibrium ie across which there is no flux of gravitational radiation or matter fields. They define an isolated horizon by means of certain boundary conditions. They state that these boundary conditions as well as the overall viewpoint are closely related to the work of Hayward. However, they do not give a 'direct' definition of the black hole. Nevertheless, their work gives importance to cosmological horizons as do Joshi and Narlikar.

Next we consider some of the issues directly related to our investigations and which we shall address in the present thesis.

1. Tests: This has to do with the issue as to whether the properties of the well-known black holes are retained, modified or radically altered. We shall exemplify these three possibilities and draw attention to the nature of the modifications that take place.
2. Physical phenomena: One would like to know whether anything new happens.
3. Exploration towards more realistic models: The nature of the modifications or the simplicity of the model may indicate the appropriateness of the prototype black hole on which to base our investigations. This may involve the theory of exact solutions which is beyond the scope of this thesis.

We now discuss the mode of investigation that we employ.

1.4 Our Approach

The approach that we shall take in investigating black holes in non-flat backgrounds may be outlined as follows.

- Consider specific examples: This conforms well to the historical evolution of the field of black holes. It was initially by the studies on the Schwarzschild and the Kerr black holes that the motivation for, and development, of the formalism took place. Investigations on the local properties of these black holes gave rise to the need to introduce suitable generalizations incorporating global methods as well. Studies on physical phenomena in the gravitational field of these black holes led to much of the presently well-known theorems such as, for instance, the area theorem along with the concept of the irreducible mass.
- Relax conditions step by step: Dropping at once all the features of the usual black holes may prove to be too formidable to handle as a first step. For instance, relaxing time independence deprives us of the timelike vector field which goes into defining the black hole. As a concrete illustration, the Vaidya cosmological-black hole metric, which we shall discuss below, having the Einstein static universe as the background spacetime naturally admits a timelike Killing vector field. However, as we shall discuss later on, its non-static counterpart given by Vaidya himself does not satisfy the

definition of a black hole as being a null surface with the light cone tangential to it. Therefore, in the present thesis we retain time independence but drop asymptotic flatness.

- Accumulate a sizeable body of knowledge: As in the case of the Schwarzschild and the Kerr black holes, possessing a substantial body of knowledge and results on specific examples makes it easier to proceed towards generalizations. Moreover, this step serves as a selection criterion for the specific examples by allowing us to restrict attention to those which retain the desirable properties of black holes.
- Study issues that emerge: In course of investigations, as in fact borne out by the present work, it is natural that further issues may arise. A study of these may shed light on the issues that confronted us at the starting point itself. We shall find several illustrations of this in the succeeding chapters.

We turn now to a discussion of possible specific examples of black holes in non-flat backgrounds.

1.5 Prototypes of Black Holes in Non-Flat Backgrounds

In an attempt to arrive at a suitable choice of a prototype we may mention here some previous work related to black holes in non-flat backgrounds. For instance, McVittie considered the spacetime corresponding to a mass-particle in an expanding universe[8][9][10]. The metric, at a first glance, seems to admit an event horizon. However it can be shown that the spacetime becomes singular on this surface and the interior is not defined at all. As such this spacetime may represent essentially a mass-particle rather than a black hole in an expanding universe. For further properties and problems associated with the work of McVittie, we refer to Sussman[11]. There are also studies in the literature based on the so called ‘Swiss-cheese model’. Einstein and Straus[10][12] constructed a model which comprises a cavity enclosing a Schwarzschild vacuum spacetime which includes the black hole; exterior to the cavity is the Friedman cosmological spacetime. The above two models have been employed to study the influence of the cosmological expansion on planetary orbits as was done, for instance, by Gautreau[13](see also Brauer[14]). This study has been extended to the case of a slowly rotating black hole by Chamorro[15].

All the above models essentially contain cavities. This shortcoming is remedied by the Vaidya spacetime. The Vaidya spacetime is of a very special kind in that it connects the black hole and the Einstein universe. The regular black holes form a member of the family represented by the Vaidya metric. In the limit we do obtain the regular black holes. This is not possible, for instance, for models having the De Sitter universe as background. Thus the Vaidya family provides the best prototype for our investigations.

1.6 The Vaidya Cosmological-Black Hole Metric

The Vaidya cosmological-black hole metric which we shall be dealing with was derived by Vaidya in 1977. We may point out that this is in no way related to the Vaidya radiating metric given by him earlier. His approach towards obtaining the metric is to take any suitable background metric and to make a transformation to rotating spheroidal coordinates. By making certain adjustments, he then arrives at the cosmological black hole metric. In the limit as we have noted earlier, we recover the usual black hole metric and the metric of the Einstein universe. The energy-momentum tensor is derived through the Einstein field equations. In the present thesis we confine ourselves to the Einstein universe as background.

1.7 Outline of the Present Investigations

In the present thesis we study both the Vaidya-Einstein-Schwarzschild and the Vaidya-Einstein-Kerr spacetimes. In Chapter 2, we investigate some physical effects in the VES spacetime. These include the classical tests namely the gravitational redshift, perihelion precession and light bending and a study of the geodesics. We move on to the VEK spacetime in Chapter 3 focusing on the geometry and physics of the event horizon. By computing the equatorial and polar circumferences we examine the oblateness of the horizon as a function of the background parameter. We discuss the behavior of the surface area and the angular velocity of the horizon as the background parameter is varied. We compute the Gaussian curvature and discuss conditions for embedding the horizon in Euclidean space. This will be followed by an investigation of some physical effects in the VEK spacetime in Chapter 4. These include circular geodesics and the gyroscopic precession. In Chapter 5, we study the Carter constant and the Petrov classification of the VEK spacetime. We construct the Killing tensor, the Killing spinor and the Killing-Yano tensor. In Chapter 6, we investigate the structure of the geodesic particle angular momentum analogues in the VEK spacetime by means of the Killing-Yano tensor. Chapter 7 contains a brief summary and conclusion of this thesis. Throughout this work we compare and contrast the results obtained in the case of black holes in non-flat backgrounds with that of their asymptotically flat background counterparts.

**BLACK HOLES
IN
COSMOLOGICAL BACKGROUNDS**

*A thesis
submitted for the degree of
Doctor of Philosophy
in the Faculty of Science
University of Calicut, India*

B. S. Ramachandra

**Indian Institute of Astrophysics
Bangalore, India**

March 2003

Chapter 2

The Vaidya-Einstein-Schwarzschild Black Hole: some physical effects

2.1 Introduction

In the previous chapter we discussed the motivation underlying our investigations on black holes in non-flat backgrounds. We elucidated the reasons for choosing the Vaidya cosmological spacetimes as being the most suitable spacetimes for our studies. In the present chapter we take as a starting point, a special case of the Vaidya cosmological spacetimes. This is the spacetime of the static, spherically symmetric Schwarzschild black hole in the background of the Einstein universe. As mentioned in Chapter 1, Nayak, MacCallum and Vishveshwara[3] constructed a composite static spacetime called the Vaidya-Einstein-Schwarzschild (VES) spacetime, as an example of a black hole in a non-flat background. As a physical effect they studied the behaviour of scalar waves in this spacetime.

We now study some more physical effects such as the classical tests and geodesics in the VES spacetime[21].

The organization of this chapter is as follows. In Section 2.2, we describe the VES metric as given in [3] and outline the salient points that led to the construction of the composite spacetime. In Section 2.3, we decompose the VES metric into a background and a black hole component. This is analogous to the expression of the Kerr metric in terms of Kerr-Schild coordinates, as will be clarified in the same section. This ‘background-black hole decomposition’ allows for a convenient separation of the effects due to the background spacetime and due to the black hole respectively. This type of decomposition is found to be useful and instructive in discussing physical effects as well. As an example we consider the geodesic Lagrangian. We may point out that this decomposition would be of considerable utility if one has to deal with the Kerr black hole in the background of the Einstein universe as we shall see in Chapter 6. Section 2.4 comprises the computations of the classical tests, namely the gravitational redshift, the perihelion precession and the

bending of light, modified by the non-flat background spacetime. Geodesics are studied in Section 2.5 and are shown to undergo significant changes because of the background of the VES spacetime as compared with the usual Schwarzschild spacetime. This study includes the structure of circular geodesics and the classification of geodesics in general. Section 2.6 carries some concluding remarks.

2.2 The Vaidya-Einstein-Schwarzschild (VES) Spacetime

The Kerr metric in the background of a homogeneous model of the universe rather than in the standard Minkowskian background was given by Vaidya[2]. This metric contains both the Kerr metric and the metric of the Einstein universe as limiting cases. The special case of this metric, the Schwarzschild metric in the background of the Einstein universe has been investigated in detail by Nayak, MacCallum and Vishveshwara[3] who constructed a composite spacetime called the Vaidya-Einstein-Schwarzschild (VES) spacetime. We take this VES spacetime as our starting point, the metric of which may be presented as

$$ds_{ves}^2 = \left(1 - \frac{2M}{R \tan(\frac{r}{R})}\right) dt^2 - \left(1 - \frac{2M}{R \tan(\frac{r}{R})}\right)^{-1} dr^2 - R^2 \sin^2\left(\frac{r}{R}\right) (d\theta^2 + \sin^2 \theta d\phi^2) \quad (2.1)$$

where, M is the mass parameter and the coordinates range from $0 \leq r/R \leq \pi$, $0 \leq \theta \leq \pi$ and $0 \leq \phi \leq 2\pi$. Here, M is termed the mass parameter because in order to define it rigorously one requires the spacetime to be asymptotically flat. Nevertheless, M indeed reduces to the mass of the Schwarzschild spacetime in the limiting case of $R \rightarrow \infty$ as we shall show below.

This metric incorporates both the Schwarzschild black hole and the Einstein universe as limiting cases. As R goes to infinity, we obtain the Schwarzschild spacetime

$$ds^2 = \left(1 - \frac{2M}{r}\right) dt^2 - \left(1 - \frac{2M}{r}\right)^{-1} dr^2 - r^2 (d\theta^2 + \sin^2 \theta d\phi^2) \quad (2.2)$$

and as M goes to zero we obtain the Einstein universe

$$ds^2 = dt^2 - dr^2 - R^2 \sin^2(r/R) (d\theta^2 + \sin^2 \theta d\phi^2) \quad (2.3)$$

The parameter R represents the influence of the cosmological background on the black hole. Smaller the value of R , greater the background influence. In view of this we shall denote R as the background parameter, which originally started off in the formalism as the scaling parameter in the Einstein universe. The background can also be viewed simply as matter distribution characterized by R . The event horizon of the black hole is at

$$R \tan(r/R) = 2M \quad (2.4)$$

Returning to the metric(2.1), the metric of the interior of the event horizon is taken to be that of the Schwarzschild vacuum with mass parameter M_s . The metric of this region is therefore

$$ds_s^2 = \left(1 - \frac{2M_s}{r}\right) dt^2 - \left(1 - \frac{2M_s}{r}\right)^{-1} dr^2 - R^2 \sin^2\left(\frac{r}{R}\right) (d\theta^2 + \sin^2\theta d\phi^2) \quad (2.5)$$

In ref[3], it has been shown that the metrics(2.1) and (2.2) can be smoothly matched across the event horizon. In their paper the authors use Kruskal coordinates for the vacuum Schwarzschild and the VES metric in order to perform the matching. We summarize the essential steps below.

The Kruskal form of the VES line element is given by

$$ds^2 = \left(\frac{4MR^2}{4M^2 + R^2}\right)^2 \frac{1}{R \sin(r/R)} e^{-r/2M} d\hat{U} d\hat{V} - (R \sin(r/R))^2 d\Omega^2 \quad (2.6)$$

The Kruskal line element for the Schwarzschild vacuum spacetime

$$ds^2 = 16M_s^2 \frac{1}{r_s} e^{-r_s/2M_s} d\hat{U} d\hat{V} - r_s^2 d\Omega^2, \quad (2.7)$$

may be recovered from equation (2.6) by the limit $R = \infty$.

The horizon of the VES metric is at $r = r_0$ where $2M = R \tan(r_0/R)$. To match to Schwarzschild at the horizon the angular variables part requires $2M_s = R \sin(r_0/R)$. Using $r' = R \sin(r/R)$ as the radial variable in the VES region both the \hat{U} and \hat{V} of each of the metrics may be rescaled by constant factors $4M_s/\sqrt{e}$ and $4MR^2 e^{-r_0/4M}/(4M^2 + R^2)$ respectively, giving new coordinates U, V , to reduce the metrics to the forms

$$ds^2 = \frac{1}{r'} e^{(r_0-r)/2M} dU dV - (r')^2 d\Omega^2 \quad (2.8)$$

$$ds^2 = \frac{1}{r_s} e^{(2M_s-r_s)/2M_s} dU dV - r_s^2 d\Omega^2. \quad (2.9)$$

Then we see the metric is continuous if we identify r_s and r' at the future horizon $U = 0$, $r' = r_s = 2M_s = R \sin(r_0/R)$, $r = r_0$.

The derivatives of the metric coefficients will match if

$$\frac{1}{2M} \frac{dr}{dr'} = \frac{1}{2M_s} \quad (2.10)$$

at the horizon, but $\frac{dr}{dr'} = 1/\cos(r/R)$ and $\frac{1}{2M_s} = \frac{1}{R \sin(r_0/R)}$. Therefore we obtain

$$\frac{1}{2M \cos(r_0/R)} = \frac{1}{R \sin(r_0/R)} \quad (2.11)$$

This is consistent because at the horizon $2M = R \tan(r_0/R)$.

Matching the metric component g_{33} yields the relation between the Schwarzschild vacuum mass M_s and the VES mass M

$$M = M_s \left[1 - \left(\frac{2M_s}{R} \right)^2 \right]^{-\frac{1}{2}}. \quad (2.12)$$

This clearly exhibits the influence of the cosmological matter distribution on the Schwarzschild vacuum black hole mass. Since it is required that $2M_s \leq R$ the length scale in the exterior places a bound on the black hole mass.

Next we see that at $r/R = \pi/2$ the metric (2.1) reduces to that of the Einstein universe. Here it is natural to match the Einstein universe given by equation(2.3) to the spacetime of (2.1). It has been shown that the metric components automatically match but the derivatives do not, giving rise to a surface distribution of matter. We have thus the composite VES spacetime which consists of a vacuum black hole interior which is matched across the event horizon to the spacetime of Vaidya, which in turn is matched to the Einstein universe. In other words the Vaidya spacetime now consists of three sectors namely the vacuum Schwarzschild sector, the Vaidya sector and the Einstein sector. We shall use this terminology whenever convenient.

The Schwarzschild spacetime is asymptotically flat whereas the VES spacetime is asymptotically Einstein. This may be seen directly by setting the radial coordinates r and $R \tan(r/R)$ to infinity in the respective metrics. However, in order to exhibit this feature clearly and also with a view towards future generalizations, in particular, having to do with the structure of geodetic angular momentum in the spacetime of the Kerr black hole in non-flat backgrounds in Chapter 6, we examine this feature in some detail.

2.3 The Background-Black Hole Decomposition

In order to study the effects due to the background and the black hole clearly, it is convenient to introduce the background-black hole decomposition. This idea is implicit while expressing the Kerr metric in Kerr-Schild coordinates but has not been exploited fully especially in the case of the Schwarzschild metric. This decomposition enables us to neatly separate out the various geometrical and physical quantities associated with the spacetime into background and black hole quantities. Thus attention may be given to either the background spacetime or the black hole in order to study or generalize the properties of the spacetime. In particular, the background may be extended from a flat into a non-flat one as will be shown in the following sections. In Chapter 6, we shall discuss this in greater detail.

2.3.1 The metric

For the sake of completeness we first consider the decomposition of the Schwarzschild metric. It is instructive to carry out this procedure for the Schwarzschild metric on its own rather than consider it as a special case of the Kerr metric in the Kerr-Schild form. Accordingly we begin with the Schwarzschild metric

$$ds_s^2 = \left(1 - \frac{2M_s}{r}\right) dt^2 - \left(1 - \frac{2M_s}{r}\right)^{-1} dr^2 - r^2 (d\theta^2 + \sin^2 \theta d\phi^2). \quad (2.13)$$

The corresponding Newman-Penrose (NP) null tetrad (l, n, m, \bar{m}) is given by

$$\begin{aligned} l_s &= l_a^s dx^a = dt - \frac{r^2}{\Delta} dr \\ n_s &= n_a^s dx^a = \frac{\Delta}{2r^2} l_s + dr \\ m_s &= m_a^s dx^a = -\frac{r}{\sqrt{2}} (d\theta + i \sin \theta d\phi) \\ \bar{m}_s &= \bar{m}_a^s dx^a = -\frac{r}{\sqrt{2}} (d\theta - i \sin \theta d\phi) \end{aligned} \quad (2.14)$$

where

$$\Delta = r^2 - 2M_s r \quad (2.15)$$

In terms of the above tetrad, the metric assumes the form,

$$\begin{aligned} ds_s^2 &= 2(l_s \otimes n_s - m_s \otimes \bar{m}_s) \\ g_{ab}^s &= l_a^s n_b^s + l_b^s n_a^s - m_a^s \bar{m}_b^s - m_b^s \bar{m}_a^s \end{aligned} \quad (2.16)$$

We make a transformation

$$dx^0 = dt - \frac{2M_s r^2}{r \Delta} dr \quad (2.17)$$

which enables us to express the metric as

$$ds_s^2 = (dx^0)^2 - dr^2 - r^2 (d\theta^2 + \sin^2 \theta d\phi^2) - \frac{2M_s}{r} (dx^0 - dr)^2 \quad (2.18)$$

with the corresponding NP tetrad

$$\begin{aligned} l_s &= dx^0 - dr \\ n_s &= \frac{\Delta}{2r^2} (dx^0 - dr) + dr \\ m_s &= -\frac{r}{\sqrt{2}} (d\theta + i \sin \theta d\phi) \\ \bar{m}_s &= \bar{m}_a dx^a = -\frac{r}{\sqrt{2}} (d\theta - i \sin \theta d\phi) \end{aligned} \quad (2.19)$$

The flat metric

$$ds^2 = (dx^0)^2 - dr^2 - r^2 (d\theta^2 + \sin^2 \theta d\phi^2) \quad (2.20)$$

on the other hand, has the NP tetrad

$$\begin{aligned}
l_f &= dx^0 - dr \\
n_f &= \frac{1}{2}(dx^0 + dr) \\
m_f &= -\frac{r}{\sqrt{2}}(d\theta + i \sin \theta d\phi) \\
\bar{m}_f &= -\frac{r}{\sqrt{2}}(d\theta - i \sin \theta d\phi)
\end{aligned} \tag{2.21}$$

The above transformation allows us to express the NP tetrad of the Schwarzschild metric entirely in terms of the tetrad of the flat background spacetime.

$$\begin{aligned}
l_s &= l_f \\
n_s &= n_f - \frac{M_s}{r} l_f \\
m_s &= m_f \\
\bar{m}_s &= \bar{m}_f
\end{aligned} \tag{2.22}$$

And the metric splits into a flat background metric and a term involving the tetrad of the flat background spacetime

$$\begin{aligned}
ds_s^2 &= ds_f^2 - h_s l_f \otimes l_f, \\
g_{ab}^s &= \eta_{ab} - h_s l_a^f l_b^f
\end{aligned} \tag{2.23}$$

where, $h_s = 2M_s/r$ and f refers to the flat background. We see that the information about the black hole is contained entirely in just one of the tetrad, n_s .

As r goes to infinity, the second term goes to zero and the metric coincides with the metric of the flat background spacetime. This shows that the metric is asymptotically flat. Turning now to the case where we have an asymptotically Einstein background, by a construction closely following the Schwarzschild case, we arrive at the decomposed metric for the VES spacetime.

$$ds_{ves}^2 = ds_e^2 - h l_e \otimes l_e \tag{2.24}$$

where, $h = 2M/R \tan(r/R)$, e refers to the Einstein background. The corresponding NP tetrad is

$$\begin{aligned}
l_{ves} &= dt - \frac{\bar{r}^2}{\bar{\Delta}} dr \\
n_{ves} &= \frac{\bar{\Delta}}{2r^2} l_{ves} + dr \\
m_{ves} &= -\frac{\bar{r}}{\sqrt{2}}(d\theta + i \sin \theta d\phi) \\
\bar{m}_{ves} &= -\frac{\bar{r}}{\sqrt{2}}(d\theta - i \sin \theta d\phi)
\end{aligned} \tag{2.25}$$

where,

$$\begin{aligned}\bar{r}^2 &= R^2 \sin^2(r/R) \\ \underline{r} &= R \sin(r/R) \cos(r/R) \\ \bar{\Delta} &= \bar{r}^2 - 2M\underline{r} = \bar{r}^2(1 - 2M/R \tan(r/R))\end{aligned}\quad (2.26)$$

A generalized transformation

$$d\bar{x}^0 = dt - \frac{2M}{R \tan(r/R)} \frac{\bar{r}^2}{\bar{\Delta}} dr \quad (2.27)$$

enables us to express the VES metric as a combination of a non-flat Einstein metric and a term involving the NP tetrad of the Einstein background spacetime.

$$ds_{ves}^2 = ds_e^2 - h l_e \otimes l_e \quad (2.28)$$

$$g_{ab}^{ves} = g_{ab}^e - h l_a^e l_b^e \quad (2.29)$$

the NP tetrad being given by

$$\begin{aligned}l_{ves} &= l_e \\ n_{ves} &= n_e - \frac{M}{R \tan(r/R)} l_e \\ m_{ves} &= m_e \\ \bar{m}_{ves} &= \bar{m}_e\end{aligned}\quad (2.30)$$

As $R \tan(r/R)$ goes to infinity, the second term in the VES metric goes to zero and the metric coincides with the metric of the Einstein universe. This shows that the metric is asymptotically Einstein. As in the Schwarzschild case this form of the metric is known as the generalized Kerr-Schild form[10], the term ‘generalized’, referring to the non-flat nature of the background spacetime. It is interesting to observe that the VES metric may be expressed as a combination of the flat metric and two other terms. This is because the Einstein metric may be written as

$$ds_e^2 = (dx^0)^2 - (d\bar{x})^2 - (d\bar{y})^2 - (d\bar{z})^2 - \frac{(\bar{x}d\bar{x} + \bar{y}d\bar{y} + \bar{z}d\bar{z})^2}{(R^2 - \bar{x}^2 - \bar{y}^2 - \bar{z}^2)} \quad (2.31)$$

where \bar{x}, \bar{y} and \bar{z} are cartesian-like coordinates defined by

$$\begin{aligned}\bar{x} &= R \sin(r/R) \cos \phi \sin \theta \\ \bar{y} &= R \sin(r/R) \sin \phi \sin \theta \\ \bar{z} &= R \sin(r/R) \cos \theta \\ x^0 &= u + r\end{aligned}$$

whence,

$$ds_e^2 = ds_f^2 - \frac{(\bar{x}d\bar{x} + \bar{y}d\bar{y} + \bar{z}d\bar{z})^2}{(R^2 - \bar{x}^2 - \bar{y}^2 - \bar{z}^2)} \quad (2.32)$$

Thus the VES metric may be expressed as

$$ds_{ves}^2 = ds_f^2 - \frac{(\bar{x}d\bar{x} + \bar{y}d\bar{y} + \bar{z}d\bar{z})^2}{(R^2 - \bar{x}^2 - \bar{y}^2 - \bar{z}^2)} - h l_e \otimes l_e \quad (2.33)$$

This clearly shows that as R goes to infinity the VES metric goes over into the metric of the vacuum black hole

$$ds_s^2 = ds_f^2 - 2\frac{M_s}{r} l_f \otimes l_f \quad (2.34)$$

As M goes to zero, it goes over into the metric of the Einstein universe

$$ds_{ves}^2 = ds_f^2 - \frac{(x dx + y dy + z dz)^2}{(R^2 - x^2 - y^2 - z^2)} \quad (2.35)$$

It is expected that the background-black hole decomposition may be carried out in the case of black hole spacetimes other than the Einstein universe facilitating thereby to find new solutions of black holes in non-flat backgrounds, especially in the background of an expanding universe.

2.3.2 The geodesic Lagrangian

Proceeding in the spirit of the previous subsection, we decompose the test particle Lagrangian and write it as the sum of the background and the black hole terms. The background term may be thought of as a kinetic energy term and the black hole term may be thought of as a potential energy term, in analogy with the usual Lagrangian formalism. This allows us to decompose the conserved quantities into corresponding background and black hole terms as well.

It is instructive to recall the usual geodesic Lagrangian method. As is well known, the equations governing the geodesics in a spacetime with the line element

$$ds^2 = g_{ab} dx^a dx^b \quad (2.36)$$

can be derived from the Lagrangian

$$\mathcal{L} = \frac{1}{2} \left(\frac{ds}{d\tau} \right)^2 \quad (2.37)$$

where τ is an affine parameter which is usually identified with the proper time, for time-like geodesics.

For the VES spacetime, the Lagrangian is

$$\mathcal{L} = \frac{1}{2} \left[\left(1 - \frac{2M}{R \tan(\frac{r}{R})} \right) \dot{t}^2 - \left(1 - \frac{2M}{R \tan(\frac{r}{R})} \right)^{-1} \dot{r}^2 - R^2 \sin^2 \left(\frac{r}{R} \right) (\dot{\theta}^2 + \sin^2 \theta \dot{\phi}^2) \right] \quad (2.38)$$

where the dot denotes differentiation with respect to τ . As in the Schwarzschild case, without loss of generality, we confine the geodesics to the equatorial plane defined by $\theta = \pi/2$. We then have

$$\mathcal{L} = \frac{1}{2} \left[\left(1 - \frac{2M}{R \tan(\frac{r}{R})}\right) \dot{t}^2 - \left(1 - \frac{2M}{R \tan(\frac{r}{R})}\right)^{-1} \dot{r}^2 - R^2 \sin^2\left(\frac{r}{R}\right) \dot{\phi}^2 \right] \quad (2.39)$$

The above Lagrangian has two conserved quantities coming from the cyclic coordinates t and ϕ , defined by

$$\left(1 - \frac{2M}{R \tan(\frac{r}{R})}\right) \dot{t} = E \quad (2.40)$$

the energy and

$$R^2 \sin^2(r/R) \dot{\phi} = L \quad (2.41)$$

the azimuthal angular momentum. In terms of these constants, the Lagrangian becomes

$$\mathcal{L} = \frac{1}{2} \left[\frac{E^2}{1 - 2M/R \tan(r/R)} - \frac{\dot{r}^2}{1 - 2M/R \tan(r/R)} - \frac{L^2}{R^2 \sin^2(r/R)} \right] \quad (2.42)$$

For time like geodesics, we have $\mathcal{L} = \frac{1}{2}(ds/d\tau)^2 = 1$, and hence

$$\frac{E^2}{1 - 2M/R \tan(r/R)} - \frac{\dot{r}^2}{1 - 2M/R \tan(r/R)} - \frac{L^2}{R^2 \sin^2(r/R)} = 1 \quad (2.43)$$

which immediately gives

$$\dot{r}^2 + V^2(r) = E^2 \quad (2.44)$$

where

$$V^2(r) = \left(1 - \frac{2M}{R \tan(\frac{r}{R})}\right) \left(1 + \frac{L^2}{R^2 \sin^2 \frac{r}{R}}\right) \quad (2.45)$$

is the effective potential for particle motion described by the above Lagrangian.

2.3.3 The decomposed geodesic Lagrangian and conserved quantities

The background-black hole decomposition of the test particle Lagrangian is obtained by taking the corresponding decomposed metric and forming the Lagrangian as

$$\mathcal{L} = \frac{1}{2} \left[(\dot{x}^0)^2 - \dot{r}^2 - R^2 \sin^2\left(\frac{r}{R}\right) \dot{\phi}^2 \right] - (1/2)h(l_a \dot{x}^a)^2 \quad (2.46)$$

which may be written as

$$\mathcal{L} = \mathcal{L}_e - (1/2)h(l_a \dot{x}^a)^2 \quad (2.47)$$

with the Lagrangian for the test particle in the Einstein universe alone given by

$$\mathcal{L}_e = \frac{1}{2} \left[(\dot{x}^0)^2 - \dot{r}^2 - R^2 \sin^2\left(\frac{r}{R}\right) \dot{\phi}^2 \right] \quad (2.48)$$

The conjugate momenta are

$$P_a^{ves} = \partial \mathcal{L} / \partial \dot{x}^a - h(l_a \dot{x}^a) l_a \quad (2.49)$$

and therefore

$$P_a^{ves} = P_a^e - h(l_a \dot{x}^a) l_a \quad (2.50)$$

where

$$P_a^e = \partial \mathcal{L}_e / \partial \dot{x}^a \quad (2.51)$$

and the two conserved quantities, the energy E and the azimuthal angular momentum L are therefore given by

$$E_{ves} = E_e - h(l_a \dot{x}^a) l_0 \quad (2.52)$$

$$L_{ves} = L_e \quad (2.53)$$

which indicates clearly that the energy receives a contribution from both the background and the black hole and that the azimuthal angular momentum is due only to the Einstein background.

We shall see that the above decomposition will be more relevant when we study the classical tests. Here we exhibit plots of the effective potential for particle motion after noting that the L appearing in equation 2.45 is just L_e .

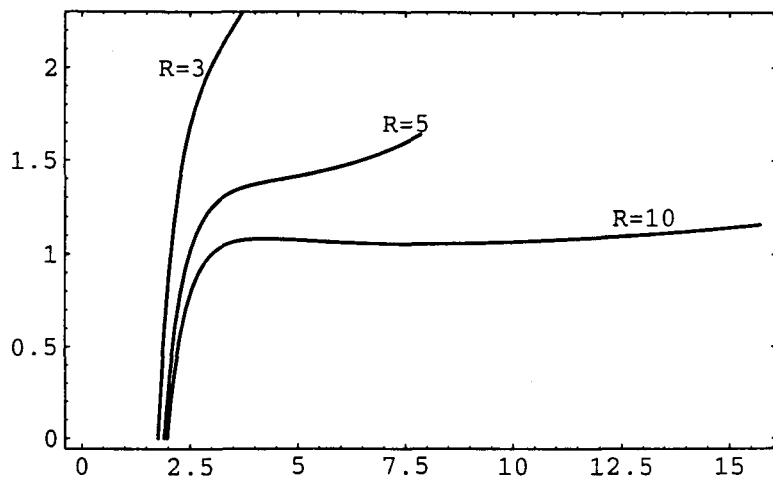

Figure 2.1: Plot of the effective potential $V(r)$ for $M = 1$, $L = 6$

The qualitative features of the orbits may be discerned from the plot of the effective potential against r . A detailed discussion of such a plot for the Schwarzschild spacetime is given in various standard sources [16] and the same may be done for the present case. As a detailed discussion based on a different approach will be given below we merely present here the plot for various values of R , indicating the degree of cosmological influence. At small values of R , the influence of the cosmological background is so large that there is an enormous modification in the nature of the orbits. At large values of R the orbits tend to their Schwarzschild character as the cosmological influence decreases.

2.4 The Classical Tests

A study of the classical tests, namely the gravitational redshift, the perihelion precession and light bending, of the VES spacetime shows how the non-flat nature of the background spacetime affects the Schwarzschild results. The non-flat background manifests itself through the parameter R . This is more so in the case of the perihelion precession and light bending than in the case of the gravitational redshift to which we turn first.

2.4.1 The gravitational redshift.

It is instructive to study the gravitational redshift first as it is the simplest among the classical tests. In the usual Schwarzschild case we can find the ratio of the frequencies of light emitted at a certain point in the spacetime and observed at another, to be given by[16]

$$\nu_O/\nu_E = (\sqrt{g_{00}})_E/(\sqrt{g_{00}})_O = \sqrt{(1 - 2M_s/r)_E}/\sqrt{(1 - 2M_s/r)_O} \quad (2.54)$$

where, ν_O and ν_E are the frequencies of light observed and emitted, with subscripts O and E referring to the observer and emitter, respectively and g_{00} the metric tensor component.

In the VES case, however, due to the presence of different sectors, the effect becomes much more interesting. We can consider the gravitational redshift seen by a static observer in the Einstein sector due to light emitted in the Vaidya sector. In the general case, the ratio of frequencies is given by

$$\nu_O/\nu_E = \sqrt{(1 - h)_E}/\sqrt{(1 - h)_O} \quad (2.55)$$

and in terms of the Schwarzschild mass M_s , this becomes

$$\begin{aligned} \nu_O/\nu_E &= \left(\left(1 - \frac{2M_s}{\sqrt{1 - 2M_s^2/R^2}} / (R \tan(r/R)) \right)_e \right)^{1/2} \\ &\times \left(\left(1 - \frac{2M_s}{\sqrt{1 - 2M_s^2/R^2}} / (R \tan(r/R)) \right)_e \right)^{-1/2} \end{aligned} \quad (2.56)$$

When light is emitted from a point in the Vaidya sector $\pi/2 < r/R < \pi$ and received by a static observer in the Einstein sector, we have

$$\nu_o/\nu_e = (\sqrt{g_{00}})_o/(\sqrt{g_{00}})_e = \sqrt{\left(1 - \frac{2M_s}{\sqrt{1 - 4M_s^2/R^2}} / (R \tan(r/R)) \right)_e^{-1/2}} \quad (2.57)$$

When both the observation and the emission points are in the Einstein sector the redshift is absent as is expected.

2.4.2 Perihelion precession

In order to consider the effect of perihelion precession in the VES spacetime, and to make the discussion analogous to the Schwarzschild case, it is convenient to define $\bar{u} = 1/R \tan(r/R)$ and do a similar calculation as in that case. the orbit equation for time-like geodesics is given by, [16]

$$\frac{d^2\bar{u}}{d\phi^2} + \bar{u} = M\left(\frac{1}{L_e^2} + \frac{1}{R^2}\right) + 3M\bar{u}^2 \quad (2.58)$$

By treating the second term on the right hand side as a perturbation, we obtain the solution

$$\bar{u} = M\left(\frac{1}{L_e^2} + \frac{1}{R^2}\right)\left[1 + e \cos \phi\left(1 - 3M^2\left(\frac{1}{L_e^2} + \frac{1}{R^2}\right)\right)\right] \quad (2.59)$$

where e is a constant emerging after integration, the eccentricity of the orbit as in the Schwarzschild case.

The perihelion shift is

$$\Delta\phi = 3M^2\left(\frac{1}{L_e^2} + \frac{1}{R^2}\right) \quad (2.60)$$

which in terms of the mass M_s is

$$\Delta\phi = 3M_s^2(1 - 4m_s^2/R^2)^{-1}\left(\frac{1}{L_e^2} + \frac{1}{R^2}\right) \quad (2.61)$$

and to second order in $1/R$ may be expressed as

$$\Delta\phi = \frac{3M_s^2}{L_s^2}\Delta\phi_s + \frac{3M_s^2}{R^2}\left(1 + \frac{4M_s^2}{L_e^2}\right) \quad (2.62)$$

where the subscript s indicates the Schwarzschild quantities. Thus the presence of the cosmological background, increases the perihelion precession.

2.4.3 Bending of light

The discussion here is similar to that in the above section. The orbit equation for null geodesics[16] is given by

$$\frac{d^2\bar{u}}{d\phi^2} + \bar{u} = \frac{M}{R^2} + 3M\bar{u}^2 \quad (2.63)$$

For small values such that the second term on the right hand side can be treated as a perturbation, we obtain the solution

$$\bar{u} = \frac{M}{R^2} + \frac{\cos \phi}{b} + \frac{3M^2}{R^2b}\phi \sin \phi + \frac{3M}{b^2}(\cos^2 \phi + 2 \sin^2 \phi) \quad (2.64)$$

where b is the impact parameter usually taken as the radius of the source.

Introducing cartesian-like coordinates

$$\begin{aligned}\bar{x} &= R \tan(r/R) \cos \phi \\ \bar{y} &= R \tan(r/R) \sin \phi\end{aligned}\tag{2.65}$$

we obtain

$$\bar{x} = b \pm \left[\frac{2M}{b} + \frac{M}{R^2}(b + 3M) \right] \bar{y}\tag{2.66}$$

whence, the deflection angle-the difference between the angular coefficients of the two asymptotes of the above equation-, is

$$\Delta = 2 \left[\frac{2M}{b} + \frac{M}{R^2}(b + 3M) \right]\tag{2.67}$$

$$\tag{2.68}$$

Which may be expressed in terms of the mass M_s as

$$\Delta = 2M_s(1 - 4M_s^2/R^2)^{-1/2} \left[\frac{2}{b} + \frac{1}{R^2}(b + 3M_s(1 - 4M_s^2/R^2)^{-1}) \right]\tag{2.69}$$

$$\tag{2.70}$$

and to second order in $1/R$ we have

$$\Delta = \frac{b_s}{b} \Delta_s + \frac{2M_s}{R^2} \left(b + 3M_s + \frac{2M_s^2}{b} \right)\tag{2.71}$$

where b_s represents the Schwarzschild quantity obtained as a limiting case when $R \rightarrow \infty$. We see that the presence of R causes an increase in the bending of light. This effect is analogous to that in perihelion precession.

2.5 Geodesics in the VES spacetime

A study of the geodesics is the direct route towards gaining qualitative and quantitative insight into the nature of the spacetime. First we study circular geodesics. Next we present a brief classification of the geodesics in general.

2.5.1 Circular geodesics

We first investigate the simpler case of circular geodesics by the method of Killing vectors given by Iyer and Vishveshwara[20]. The VES metric admits a time-like Killing vector ξ^a and a rotational Killing vector η^a .

$$\begin{aligned}\xi^a &= (1, 0, 0, 0) \\ \eta^a &= (0, 0, 0, 1)\end{aligned}\tag{2.72}$$

We form the combination

$$\chi^a = \xi^a + \omega \eta^a\tag{2.73}$$

where ω is the angular velocity.

Confining to the equatorial plane, we obtain by equating the derivative with respect to r of the norm $\chi^a \chi_a$ to zero, the generalized Kepler law in the Vaidya sector of the VES spacetime

$$\omega^2 = M/[R^3 \sin^3(\frac{r}{R}) \cos(\frac{r}{R})] \quad (2.74)$$

which in terms of the schwarzschild mass M_s is given by

$$\omega^2 = M_s(1 - 4M_s^2/R^2)^{-1/2}/(R^3 \sin^3(\frac{r}{R}) \cos(\frac{r}{R})) \quad (2.75)$$

For R going to infinity we recover the usual Kepler law

$$\omega^2 = M_s/r^3 \quad (2.76)$$

for the Schwarzschild spacetime.

For M going to zero, ie in the Einstein universe

$$\omega^2 = 0 \quad (2.77)$$

and there are no circular geodesics as is expected.

Let us consider the time-like and null circular geodesics, the condition being

$$\chi^a \chi_a = g_{00} + \omega^2 g_{33} \geq 0 \quad (2.78)$$

This and the generalized Kepler law together lead to the existence of null circular geodesics at the two coordinate values: The inner null circular geodesic defined by

$$R \tan \frac{r}{R} = 6M/[1 + \sqrt{1 - \frac{12M^2}{R^2}}] \quad (2.79)$$

and the outer null circular geodesic defined by

$$R \tan \frac{r}{R} = 6M/[1 - \sqrt{1 - \frac{12M^2}{R^2}}] \quad (2.80)$$

with $R^2 \geq 12M^2$.

Time-like circular geodesics exist 'sandwiched' within these two limits. There are no circular geodesics beyond these values. This is analogous to the effect in the Ernst spacetime, where two null circular geodesics are present as has been pointed out by Nayak and Vishveshwara[18]. As R becomes large the inner null circular geodesic approaches the Schwarzschild value $r = 3M_s$ and the outer null circular geodesic approaches infinity. An interesting feature to note here is that of the centrifugal force reversal, which has been discussed by Prasanna[19]. The centrifugal force reverses at the inner null circular orbit by becoming inward. This is analogous to what happens in the case of the Schwarzschild spacetime. In the present case, such a reversal takes place at the outer null orbit also, as in the case of the Ernst spacetime. Since the Schwarzschild case has a null circular orbit at only $r = 3M_s$, we see that the effect of the Einstein cosmological background is in bifurcating the null circular orbit of the Schwarzschild spacetime into two thereby completely altering the nature of the Schwarzschild circular geodesics.

2.5.2 Geodesics and their classification

We now present a classification of the geodesics[17]. Going back to the orbit equation considered in Section 4, we write it as

$$\left(\frac{d\bar{u}}{d\phi}\right)^2 = f(\bar{u}) \quad (2.81)$$

where

$$f(\bar{u}) = 2M\bar{u}^3 - \bar{u}^2 + \frac{2M}{L_e^2}\bar{u} - \left(\frac{1 - E_{ves}^2}{L_e^2} + \frac{1}{R^2}\right) \quad (2.82)$$

The nature of the roots of the cubic equation

$$f(\bar{u}) = 0 \quad (2.83)$$

determines the nature of the geodesics.

We take \bar{u}_1 , \bar{u}_2 and \bar{u}_3 to be the roots and refer to Chandrasekhar[17] for details of the analysis.

We note first the features of the time-like bound orbits which require that

$$\frac{1 - E_{ves}^2}{L^2} + \frac{1}{R^2} > 0 \quad (2.84)$$

or, in the background-black hole decomposed form

$$\frac{1 - E_e^2}{L_e^2} + \frac{1}{R^2} + \frac{2hE_e(l_a\dot{x}^a) - h^2(l_a\dot{x}^a)^2}{L_e^2} > 0 \quad (2.85)$$

which contains the special cases

$$\frac{1 - E_f^2}{L_f^2} + \frac{2hE_f(l_a\dot{x}^a) - h^2(l_a\dot{x}^a)^2}{L_f^2} > 0 \quad (2.86)$$

corresponding to the Schwarzschild case, with f denoting the flat quantities and

$$\frac{1 - E_e^2}{L_e^2} + \frac{1}{R^2} > 0 \quad (2.87)$$

corresponding to the case of the Einstein universe.

Without going into extensive details, we list the various cases:

There are five cases:

Case(1): For $0 < \bar{u}_1 < \bar{u}_2 < \bar{u}_3$, there exists two distinct orbits confined respectively, to the intervals

(a): $\bar{u}_1 \leq \bar{u} \leq \bar{u}_2$, an orbit which oscillates between two extreme values of the radial coordinate $\bar{u}^{-1} = R \tan(r/R)$, which we may call the orbit of the first kind and

(b): $\bar{u} \geq \bar{u}_3$, an orbit, which, starting at a certain aphelion distance, plunges into the

singularity at $R \tan(r/R) = 0$, which we may call an orbit of the second kind.

Case(2): The orbit of the first kind is a stable circular orbit and the orbit of the second kind plunges into the singularity.

Case(3): The orbit of the first kind, starts at a certain aphelion distance \bar{u}_1^{-1} and approaches the circle of radius \bar{u}_3^{-1} , asymptotically, by spiralling around it an infinite number of times. The orbit of the second kind spirals away from the same circle and plunges into the singularity.

Case(4): There is an unstable circular orbit of radius $\bar{u}_1^{-1} = \bar{u}_2^{-1} = \bar{u}_3^{-1}$.

Case(5): All orbits, starting from certain aphelion distances plunge into the singularity.

We note next the features of the time-like unbound orbits which require that

$$\frac{1 - E_e^2}{L_e^2} + \frac{1}{R^2} + \frac{2hE_e(l_a \dot{x}^a) - h^2(l_a \dot{x}^a)^2}{L_e^2} < 0 \quad (2.88)$$

There are only three cases:

Case(1): There exist orbits of the first kind restricted to the interval, $0 < \bar{u} \leq \bar{u}_2$ and orbits of the second kind with $\bar{u} \geq \bar{u}_3$

Case(2): Orbits with $\bar{u}_2 = \bar{u}_3$ which approach asymptotically a common circle, spiralling around it an infinite number of times.

Case(3): Orbits which all plunge into the singularity.

The above cases are qualitatively analogous to those occurring in the usual Schwarzschild spacetime. The quantitative differences which are considerable, are not revealed by means of this analysis. However, the null geodesics exhibit a drastic modification even in their qualitative features. To see this we consider the orbit equation for null geodesics,

$$\left(\frac{d\bar{u}}{d\phi}\right)^2 = g(\bar{u}) \quad (2.89)$$

where

$$g(\bar{u}) = 2M\bar{u}^3 - \bar{u}^2 + \frac{2M}{R^2}\bar{u} + \left(\frac{1}{D_{ves}^2} - \frac{1}{R^2}\right) \quad (2.90)$$

with

$$D_{ves} = L_e/E_{ves} = L_e/(E_e - h(l_a \dot{x}^a))$$

In the usual Schwarzschild case, the corresponding polynomial $g(u)$ is just

$$g(u) = 2M_s u^3 - u^2 + \frac{1}{D_s^2} \quad (2.91)$$

which is obtained from the above equation by tending R to infinity. Here, the nature of the roots depend on the sign of the term $1/D_s^2$ which being always positive, leads to a situation similar to the time-like unbound orbits, giving rise to three cases only.

In the VES case, however, the nature of the roots of the corresponding polynomial equation depend on the sign of the term $(1/D_{ves}^2 - 1/R^2)$ which can take on both positive and negative values depending on the value of R and leads to a situation similar to that of the time-like bound as well as time-like unbound orbits giving rise to eight cases. This makes the qualitative behaviour of the null geodesics completely different from that occurring in the Schwarzschild spacetime. As has been already mentioned, the effect of the background in altering physical phenomena occurring in the Schwarzschild spacetime is considerable.

2.6 Concluding Remarks

In the present chapter we have studied some physical effects in the composite Vaidya cosmological-black hole spacetime constructed by Nayak, MacCallum and Vishveshwara. This VES spacetime is asymptotically non-flat but is time independent. The event horizon is defined as a Killing horizon. By studying physical effects in this spacetime, we have shown that the introduction of the cosmological background modifies the Schwarzschild results considerably. In contrast to the Schwarzschild case, the nature of the null geodesics is drastically affected and the time-like circular geodesics depart significantly from their Schwarzschild counterparts. Regarding the classical tests- the gravitational redshift is modified from that in the Schwarzschild spacetime and the perihelion precession and light bending undergo an increase because of the background spacetime. These investigations allow us to conclude that the background spacetime has a clearly noticeable influence on the physical phenomena occurring in this spacetime.

**BLACK HOLES
IN
COSMOLOGICAL BACKGROUNDS**

*A thesis
submitted for the degree of
Doctor of Philosophy
in the Faculty of Science
University of Calicut, India*

B. S. Ramachandra

**Indian Institute of Astrophysics
Bangalore, India**

March 2003

Chapter 3

Geometry of the Vaidya-Einstein-Kerr Black Hole

3.1 Introduction

In the previous chapter we studied the Vaidya-Einstein-Schwarzschild black hole which represents the Schwarzschild black hole in the background of the Einstein universe. By investigating some physical effects such as the classical tests and geodesics we showed that the non-flat background leads to significant modifications of the Schwarzschild counterparts. Apart from the pronounced modifications of the classical tests, the nature of the circular geodesics as well as the classification of geodesics in general is completely altered by the presence of the background. At the same time, even in the asymptotically flat case it is well known that the introduction of rotation brings about profound changes. Thus taken together the above considerations allow us to expect that the inclusion of rotation in the asymptotically non-flat case would lead to interesting effects. In the present chapter we take up this line of investigation by studying the Kerr black hole in the background of the Einstein universe.

The Kerr black hole in the background of the Einstein universe is a stationary, axisymmetric black hole surrounded by matter distribution. As in the spherical case the cosmological-black hole spacetime given by Vaidya[2] has been found to be most suitable for our investigations. We shall call this the Vaidya-Einstein-Kerr(VEK) spacetime in analogy with its Schwarzschild counterpart referred to as the VES spacetime earlier. The scaling parameter of the Einstein universe characterizes the influence of the non-vacuum background which is no longer asymptotically flat. We show that several properties of black holes are significantly modified by the background effects. These properties include the structure of the ergosphere, the geometry of the event horizon as well as its angular velocity.

We begin this study in Section 3.2 where we describe the VEK metric as given by Vaidya and cast it in the Boyer-Lindquist form. We then present the energy momentum tensor

and discuss the structure of the event horizon and the stationary limit surface as modified by the background. In Section 3.3, we study the effect of the background on the shape of the black hole by computing the equatorial and polar circumferences. In Section 3.4, we investigate the surface area of the horizon. In Section 3.5, we discuss the angular velocity of the horizon. In Section 3.6, we examine the surface gravity and the ‘extreme’ VEK black hole. In Section 3.7, we consider the Gaussian curvature and the embedding of the surface of the horizon in Euclidean space. Section 3.8 comprises some concluding remarks.

3.2 The Vaidya-Einstein-Kerr (VEK) Spacetime

The Kerr metric represents the spacetime of a stationary, axisymmetric black hole. This spacetime is time independent and asymptotically flat. We wish to retain time independence but relax asymptotic flatness. A specific example of such a spacetime is the VEK spacetime given by Vaidya. He generalized the Kerr metric by extending the background spacetime from a flat one to a homogeneous model of the universe. Thus his cosmological rotating black hole metric represents the spacetime of a stationary, axisymmetric black hole in an asymptotically non-flat background. This metric yields, as limiting cases, both the Kerr metric and the Einstein universe expressed in spheroidal polar coordinates. The metric, in general, can be considered as representing the interaction between the black hole and the background.

Since the original paper by Vaidya is not easily accessible and for the sake of completeness we briefly outline Vaidya’s method in arriving at the VEK metric.

3.2.1 The Vaidya cosmological-black hole metric

Starting with the metric of the Einstein universe

$$ds_e^2 = (dx^0)^2 - (d\bar{x})^2 - (d\bar{y})^2 - (d\bar{z})^2 - \frac{(\bar{x}d\bar{x} + \bar{y}d\bar{y} + \bar{z}d\bar{z})^2}{(R^2 - \bar{x}^2 - \bar{y}^2 - \bar{z}^2)} \quad (3.1)$$

Vaidya makes a transformation from $(\bar{x}, \bar{y}, \bar{z})$ to spheroidal polar coordinates (r, θ, ϕ)

$$\begin{aligned} \bar{x} + i\bar{y} &= (R \sin(r/R) + ia \cos(r/R)) \sin \theta e^{i\bar{\phi}} \\ \bar{z} &= R \sin(r/R) \cos \theta \end{aligned} \quad (3.2)$$

under which the Einstein metric becomes

$$\begin{aligned} ds^2 &= dt^2 - dr^2 + 2a \sin^2 \theta d\bar{\phi} dr - \frac{((R^2 - a^2) \sin^2(r/R) + a^2 \cos^2 \theta)}{(1 - a^2 \sin^2 \theta / R^2)} d\theta^2 \\ &\quad + ((R^2 - a^2) \sin^2(r/R) + a^2 \cos^2 \theta) \sin^2 \theta d\bar{\phi}^2 \end{aligned} \quad (3.3)$$

In terms of the retarded null coordinate $u = t - r$ this takes the form

$$\begin{aligned}
ds^2 = & 2(du + a \sin^2 \theta d\tilde{\phi})dt - \frac{((R^2 - a^2) \sin^2(r/R) + a^2 \cos^2 \theta)}{(1 - a^2 \sin^2 \theta/R^2)} d\theta^2 \\
& - ((R^2 - a^2) \sin^2(r/R) + a^2 \cos^2 \theta) \sin^2 \theta d\tilde{\phi}^2 - (du + a \sin^2 \theta d\tilde{\phi})^2
\end{aligned} \tag{3.4}$$

which forms the background of the VEK metric given in[2]

$$\begin{aligned}
ds^2 = & 2(du + a \sin^2 \theta d\tilde{\phi})dt - (1 + 2M\mu)(du + a \sin^2 \theta d\tilde{\phi})^2 - \\
& \mathcal{M}^2 \left(\frac{d\theta^2}{1 - a^2 \sin^2 \theta/R^2} + \sin^2 \theta d\tilde{\phi}^2 \right)
\end{aligned} \tag{3.5}$$

where

$$\begin{aligned}
\mathcal{M}^2 &= (R^2 - a^2) \sin^2(r/R) + a^2 \cos^2 \theta \\
\mu &= \frac{R \sin(r/R) \cos(r/R)}{\mathcal{M}^2}
\end{aligned} \tag{3.6}$$

In the above, M and a are the ‘mass’ and the ‘angular momentum’ parameters respectively. These quantities are well defined in an asymptotically flat spacetime and it is not clear at the outset as to how to extend it to the non-flat case. Nevertheless, for the sake of convenience, we continue to use the terminology keeping in mind that these parameters go over to their corresponding limiting counterparts as the background influence vanishes. In the above, the coordinates range from $0 \leq r/R \leq \pi$, $0 \leq \theta \leq \pi$ and $0 \leq \phi \leq 2\pi$. At $\theta = \pi/2$ and $r/R = \pi$ the metric is singular. The former is present in the Kerr case as well and may be taken care of by going over into generalized-Kerr Schild coordinates in analogy with the Kerr case. The latter may be resolved by matching the Vaidya exterior to the Einstein universe. As in the VES case we match to the Einstein universe at $r/R = \pi/2$. At this radius the VEK line element reduces to

$$ds^2 = dt^2 - \left(1 - \frac{a^2 \sin^2 \theta}{R^2}\right) dr^2 - R^2(d\theta^2 + \sin^2 \theta d\phi^2) \tag{3.7}$$

which is the line element of the Einstein universe expressed in spheroidal polar coordinates. The metric components of the two spacetimes automatically match and the first derivatives of the tt parts is discontinuous, thereby giving rise to surface distribution of matter. The jump in the fundamental form of the $r = \text{const}$ surfaces is

$$[K_{tt}] = -\frac{MR}{(R^2 - a^2 \sin^2 \theta)^{3/2}} \tag{3.8}$$

which goes over to the VES counterpart

$$[K_{tt}] = -\frac{M}{R^2} \tag{3.9}$$

as $a \rightarrow 0$.

The Vaidya cosmological-black hole metric includes both the Kerr spacetime and the spacetime of the Einstein universe as limiting cases. In order to see this feature clearly, it is convenient to cast the metric in the Boyer-Lindquist form.

3.2.2 VEK metric in the Boyer-Lindquist form

In the case of the Kerr black hole, the Boyer-Lindquist form of the metric is found to be the most convenient one in describing the spacetime and the event horizon. We find that this is true for the VEK metric as well. We therefore proceed to cast the VEK metric in the Boyer-Lindquist form. Taking the VEK metric presented in the previous subsection, we make the transformations

$$\begin{aligned} du &= dt + f dr \\ d\tilde{\phi} &= d\phi + g dr \end{aligned} \quad (3.10)$$

where

$$\begin{aligned} f &= -\frac{2MR \sin(\frac{r}{R}) \cos(\frac{r}{R})}{(R^2 - a^2) \sin^2(\frac{r}{R}) + a^2 - 2MR \sin(\frac{r}{R}) \cos(\frac{r}{R})} \\ g &= \frac{a}{(R^2 - a^2) \sin^2(\frac{r}{R}) + a^2 - 2MR \sin(\frac{r}{R}) \cos(\frac{r}{R})} \end{aligned} \quad (3.11)$$

This brings the metric to the Boyer-Lindquist form

$$\begin{aligned} ds^2 &= (1 - 2\mu)dt^2 + \frac{\mathcal{M}^2}{(\mathcal{M}^2(1 - 2M\mu) + a^2 \sin^2 \theta)} dr^2 - \frac{\mathcal{M}^2}{(1 - a^2 \sin^2 \theta / R^2)^{-1}} d\theta^2 \\ &\quad - 2Ma\mu \sin^2 \theta dt d\phi - (\mathcal{M}^2 + a^2(1 + 2M\mu) \sin^2 \theta) \sin^2 \theta d\phi^2 \end{aligned} \quad (3.12)$$

To facilitate comparison with the Kerr metric, we develop our notation such that the VEK metric ‘looks’ similar to the Kerr metric. We define

$$\begin{aligned} \bar{r}^2 &= (R^2 - a^2) \sin^2\left(\frac{r}{R}\right), \\ \underline{r} &= R \sin\left(\frac{r}{R}\right) \cos\left(\frac{r}{R}\right) \\ \bar{\rho}^2 &= \bar{r}^2 + a^2 \cos^2 \theta \\ \bar{\Delta} &= \bar{r}^2 + a^2 - 2M\underline{r} \\ \bar{\Sigma}^2 &= (\bar{r}^2 + a^2)^2 - a^2 \sin^2 \theta \bar{\Delta}, \\ \zeta^2 &= 1 - \frac{a^2 \sin^2 \theta}{R^2}. \end{aligned} \quad (3.13)$$

In terms of these quantities the metric may be expressed as

$$ds^2 = \left(1 - \frac{2M\underline{r}}{\bar{\rho}^2}\right) dt^2 - \frac{\bar{\rho}^2}{\bar{\Delta}} dr^2 - \frac{\bar{\rho}^2}{\zeta^2} d\theta^2 - \frac{\sin^2 \theta}{\bar{\rho}^2} \bar{\Sigma}^2 d\phi^2 + 2\left(\frac{2M\underline{r} a \sin^2 \theta}{\bar{\rho}^2}\right) dt d\phi \quad (3.14)$$

As mentioned earlier, this metric incorporates both the Kerr black hole and the Einstein universe as limiting cases. As R goes to infinity, we obtain the Kerr metric in the Boyer-Lindquist coordinates

$$ds^2 = \left(1 - \frac{2Mr}{\rho^2}\right) dt^2 - \frac{\rho^2}{\Delta} dr^2 - \rho^2 d\theta^2 - \frac{\sin^2 \theta}{\rho^2} \Sigma^2 d\phi^2 + 2\left(\frac{2Mra \sin^2 \theta}{\rho^2}\right) dt d\phi \quad (3.15)$$

And as M goes to zero we obtain the Einstein universe expressed in spheroidal polar coordinates

$$ds^2 = dt^2 - \frac{\bar{\rho}^2}{\bar{r}^2 + a^2} dr^2 - \frac{\bar{\rho}^2}{\zeta^2} d\theta^2 - (\bar{r}^2 + a^2) \sin^2 \theta d\phi^2 \quad (3.16)$$

The parameter R represents the influence of the background on the black hole. In the spherical case of the VES metric, this parameter is unrestricted, ie the metric is regular for all values of R in the range $0 < R \leq \infty$. In the VEK case, however, we need the condition

$$a < R \quad (3.17)$$

to ensure the regularity of the metric coefficients.

3.2.3 The energy-momentum tensor

The VEK metric represents a non-vacuum solution which is not asymptotically flat. The energy momentum tensor is determined through the metric via the Einstein field equations

$$\mathcal{R}_{ab} - \frac{1}{2} g_{ab} \mathcal{R} = \kappa T_{ab} \quad (3.18)$$

The energy momentum tensor is taken to be that of a perfect fluid which is given by

$$T_{ab} = (\rho + p) u_a u_b - p g_{ab} \quad (3.19)$$

where $u^a = \xi^a / \sqrt{g_{00}}$ is the four velocity of a stationary observer and ξ^a is the timelike Killing vector field. The density and pressure are then given by

$$\begin{aligned} \kappa \rho &= \frac{3}{R^2} \left(1 - \frac{2M_{\underline{r}}}{\bar{\rho}^2}\right) \\ \kappa p &= -\frac{1}{R^2} \left(1 - \frac{2M_{\underline{r}}}{\bar{\rho}^2}\right) \end{aligned} \quad (3.20)$$

The stationary limit is given by $\xi^a \xi_a = g_{00} = 1 - 2M_{\underline{r}}/\bar{\rho}^2 = 0$ which shows that $\rho \geq 0$ but $p \leq 0$ everywhere outside the stationary limit and that both go to zero at the stationary limit. Nevertheless $\rho + p \geq 0$ outside the stationary limit so that the weak energy condition is satisfied which is reasonable. Furthermore $\rho \geq |p|$ and therefore the dominant energy condition is also satisfied.

3.2.4 The event horizon and the ergosphere

We now turn to study the structure of the event horizon as a function of the parameters (M, a, R) .

We may remark that when we speak of the ‘surface’ of the black hole, we are dealing essentially with a sequence of spacelike slices through the event horizon represented by a null hypersurface. This gives a family of 2-geometries which, if closed, can be thought of

as the surface of the black hole. In general, these surfaces depend on the particular slicing chosen. Nevertheless, in the VEK case, as in the Kerr case [24], the 2-geometry of the surface of the horizon is independent of the slicing. Thus we may consider the surface of the VEK black hole without reference to the slicing.

Since, therefore, the surface of the event horizon is a two dimensional manifold one would expect that only two parameters are needed to describe it. One way of doing this is for instance, by defining two new parameters in terms of the parameter R and then studying the geometry as a function of these parameters. We do not take this approach here as we wish to be able to go to the limiting cases of the Einstein and the VES black holes wherein $M = 0$ and $a = 0$ respectively. If, on the contrary, we take, for instance, $M = mR$ and $a = \alpha R$ we are led to the following restrictions. When $m = 0$ we have two possibilities, $R \rightarrow \infty$ and $M \rightarrow 0$ giving the limiting case of the flat Minkowski metric expressed in rotating coordinates. When $\alpha = 0$ we again have two possibilities $R \rightarrow \infty$ and $a \rightarrow 0$ giving the limiting case of the Schwarzschild metric. Clearly this is not suitable for obtaining the limiting cases of the Einstein and the VES metrics.

The Boyer-Lindquist form of the VEK metric is particularly convenient for calculations since orthogonal transitivity is manifestly inherent to this form of the metric. In these coordinates, we have the timelike Killing vector field $\xi = \partial/\partial t$ and the axial Killing vector field $\eta = \partial/\partial \phi$ and the condition for orthogonal transitivity

$$\epsilon^{abcd}\xi_{b;c}\xi_d\eta_a = \epsilon^{abcd}\eta_{b;c}\eta_d\xi_a = 0 \quad (3.21)$$

is satisfied.

As has been shown by Greene, Schucking and Vishveshwara[23] there exists a globally hypersurface orthogonal vector field

$$\chi = \xi + \omega_0\eta \quad (3.22)$$

with,

$$\omega_0 = -(\xi^a\eta_a)/(\eta^a\eta_a) = -g_{03}/g_{33} \quad (3.23)$$

Furthermore, the surface on which χ becomes null ($\chi^a\chi_a = 0$) is itself a null surface. In a stationary spacetime like that of VEK this is indeed the event horizon and hence defines the black hole in the Einstein background. The condition $\chi^a\chi_a = \bar{\Delta}/g_{33} = 0$ has a solution

$$R \tan(r_+/R) = M + \sqrt{M^2 - a^2} \quad (3.24)$$

where r_+ is the 'radius' of the outer event horizon.

On the other hand, as we have already mentioned, the stationary limit is given by the condition

$$\xi^a\xi_a = g_{00} = 0 \quad (3.25)$$

which has a solution

$$R \tan(r_s/R) = \frac{M + \sqrt{M^2 - (1 - a^2 \sin^2 \theta/R^2)a^2 \cos^2 \theta}}{\sqrt{1 - a^2 \sin^2 \theta/R^2}} \quad (3.26)$$

The ergosphere is the region between the event horizon and the stationary limit given

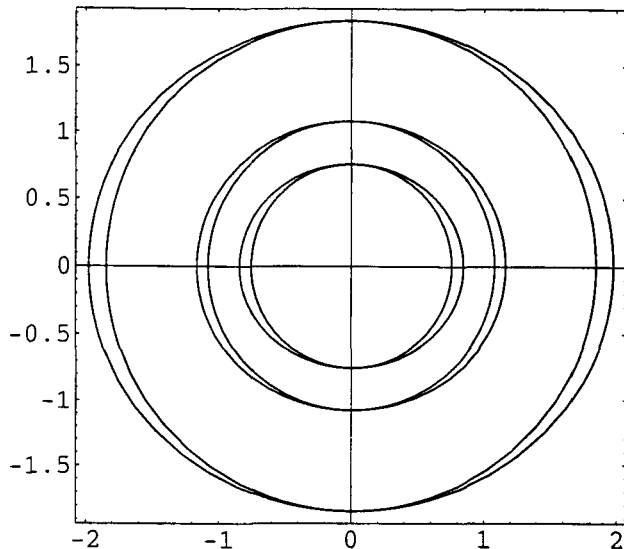

Figure 3.1: Plots of r_s and r_+ corresponding to the stationary limit and the event horizon respectively for $R = 0.6, 1, 10$ respectively going outwards from the centre. The $R = 10$ plot is almost indistinguishable from the Kerr case(not shown). Here $M = 1, a = 0.5$.

respectively by equations(3.24) and (3.26).

In figure 3.1 we show the polar plots of r_s and r_+ corresponding to the stationary limit and the event horizon respectively for different fixed values of R . These plots indicate the change in both the surfaces as R is varied. We see that for lower values of R , the shrinkage of both the stationary limit and the event horizon is more pronounced.

In figure 3.2 we have constructed the polar diagram of the functions $R \tan(r_s/R)$ and $R \tan(r_+/R)$ corresponding to the stationary limit and the event horizon respectively, for different values of R . Since $R \tan(r_+/R)$ is a constant for given values of M and a and coincides with the Kerr expression, the representation of the event horizon remains the same. However $R \tan(r_s/R)$ changes with R . Hence, the plots clearly show the changing form of the stationary limit compared to the fiducial event horizon surface. As R increases the situation tends to that in the Kerr spacetime. For lower values of R the ergosphere is larger and more distorted than in the Kerr case.

In the foregoing we have plotted the polar diagrams of the event horizon and the stationary limit only to give a feel for the changes that occur. We shall be considering the actual

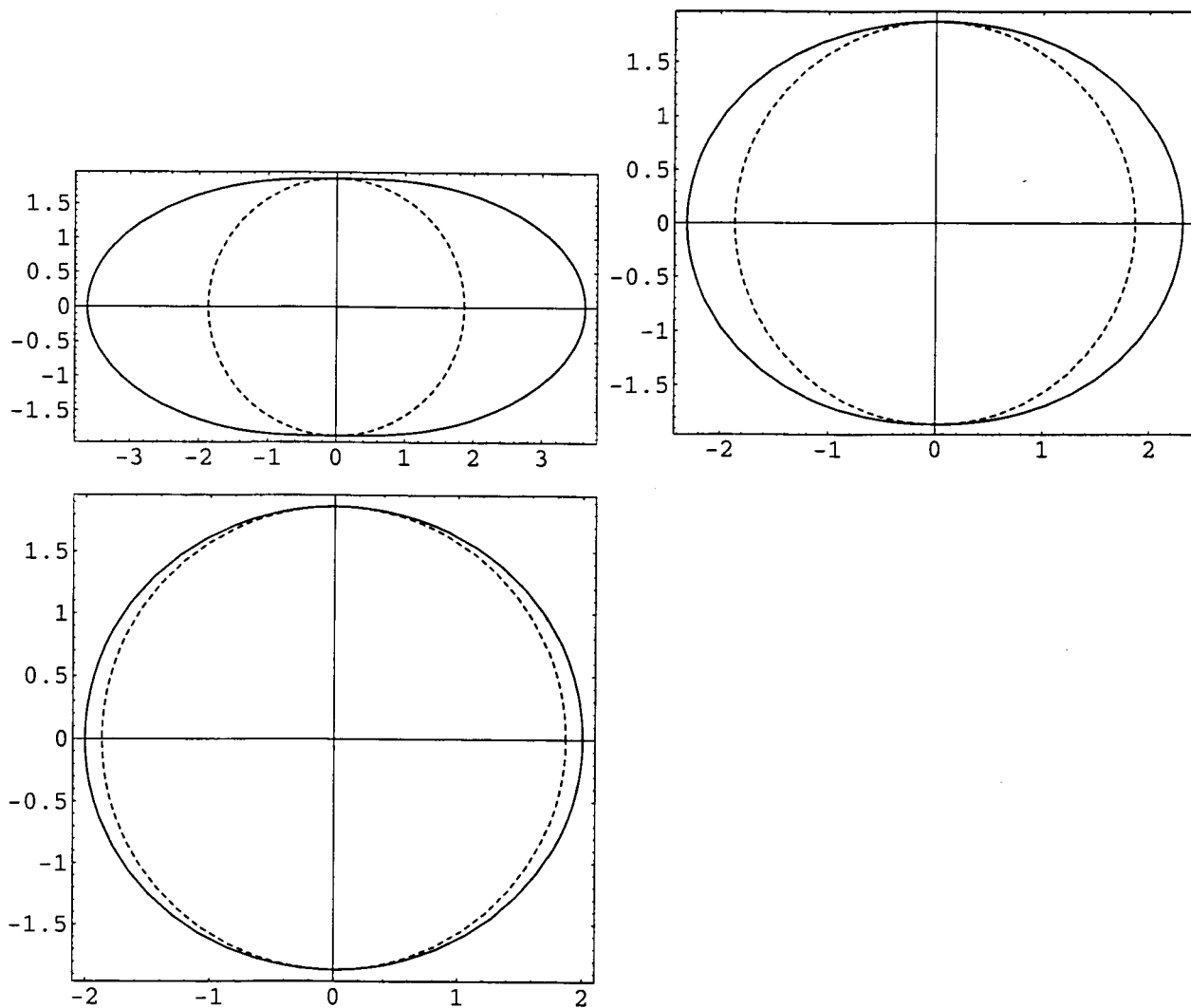

Figure 3.2: Plots of $R \tan(r_s/R)$ (the stationary limit represented by the solid curves), $R \tan(r_+/R)$ (event horizon represented by the dashed curves) for $M = 1$, $a = 0.5$ and different values of R . The values of R are 0.6(top left), 1(top right) and 10(bottom).

geometry by means of quantities which indicate more clearly the effect of the background. We shall now go on to discuss the effect of the background on the geometry of the event horizon.

3.3 The Shape of the Event Horizon

It is well known that there is a characteristic flattening of the poles and stretching of the equator when a fluid sphere is rotated. One would expect a similar effect in the case of the event horizon of a rotating black hole. The analogy with a rotating body is supported too by the fact that the angular velocity of the black hole is constant over the horizon. Smarr[24] investigated some rotational effects on the Kerr-Newmann black hole. For this purpose he introduced what he termed as the scale and the distortion parameters η and β respectively. In this paper, when we refer to the work of Smarr, it will be with respect to the case of the Kerr black hole where the charge is zero. We shall define the scale and the distortion parameters for the VEK horizon in analogy with the Kerr case as

$$\begin{aligned}\eta &= \sqrt{\bar{r}_+^2 + a^2} = \sqrt{(R^2 - a^2) \sin^2(r/R) + a^2} \\ \beta &= \frac{a}{\sqrt{\bar{r}_+^2 + a^2}} = \frac{a}{\sqrt{(R^2 - a^2) \sin^2(r/R) + a^2}}\end{aligned}\tag{3.27}$$

We see that in the VEK case, the scale and the distortion parameters depend on the background parameter as well.

We have two possible approaches which we can take while studying the geometry of the horizon. In the first approach, we hold R fixed and allow η and β to vary analogous to Smarr's original approach which is essentially equivalent to considering the effect of rotation on the horizon. In the present case this is further modified by the presence of the given background. We may therefore use this approach merely in order to compare our results with those of Smarr in the Kerr case. But in order to get a feel for the actual influence of the background, it is preferable to deal with the basic parameters a and R explicitly as we shall describe below. However, we do not entirely give up the use of the scale and distortion parameters but employ them, in particular, to classify the Gaussian curvature as in Section 3.7

In the second approach, we do not use the parameters η and β but instead, consider the explicit dependence of the geometrical quantities on the parameters a and R . Here, in turn, we have two effects which we term as the 'modulated effect' and the 'direct effect' in both of which we take M to be constant. In the case of the modulated effect, we vary the angular momentum parameter a for different values of R . Here the effect of rotation is modulated or controlled by the background parameter R . On the other hand, in the case of the direct effect, we hold a constant and vary R continuously. We shall see the differences in these two kinds of effects when we study the oblateness and the area of the

black hole.

3.3.1 The approach of Smarr

We now define the scale and distortion parameters for the event horizon of the VEK black hole. The 2-metric on the event horizon is then expressed entirely in terms of these parameters and R . The 2-metric on the event horizon of the VEK black hole is given by

$$ds^2 = \frac{\bar{\rho}_+^2}{\zeta^2} d\theta^2 + \frac{\bar{\Sigma}_+^2 \sin^2 \theta}{\bar{\rho}_+^2} d\phi^2 \quad (3.28)$$

where the subscript '+' indicates quantities on the event horizon. In terms of the dyad (θ^2, θ^3) this may be expressed as

$$ds^2 = (\theta^2)^2 + (\theta^3)^2 \quad (3.29)$$

where

$$\begin{aligned} \theta^2 &= \frac{\bar{\rho}_+}{\zeta} d\theta \\ \theta^3 &= \frac{\bar{\Sigma}_+ \sin \theta}{\bar{\rho}_+} d\phi \end{aligned} \quad (3.30)$$

The scale parameter η and the distortion parameter β for the above 2-metric are defined by

$$\begin{aligned} \eta &= \frac{\sqrt{\bar{r}_+^2 + a^2}}{a} = \frac{\sqrt{(R^2 - a^2) \sin^2(r/R) + a^2}}{a} \\ \beta &= \frac{a}{\sqrt{\bar{r}_+^2 + a^2}} = \frac{a}{\sqrt{(R^2 - a^2) \sin^2(r/R) + a^2}} \end{aligned} \quad (3.31)$$

Then the metric and the dyad forms θ^2 and θ^3 become,

$$\begin{aligned} ds^2 &= \frac{\eta^2(1 - \beta^2 \sin^2 \theta)}{1 - \eta^2 \beta^2 \sin^2 \theta / R^2} d\theta^2 + \frac{\eta^2 \sin^2 \theta}{1 - \beta^2 \sin^2 \theta} d\phi^2 \\ \theta^2 &= \frac{\eta \sqrt{1 - \beta^2 \sin^2 \theta}}{\sqrt{1 - \eta^2 \beta^2 \sin^2 \theta / R^2}} d\theta \\ \theta^3 &= \frac{\eta \sin \theta}{\sqrt{1 - \beta^2 \sin^2 \theta}} d\phi \end{aligned} \quad (3.32)$$

In the above we see that θ^3 does not depend explicitly on the parameter R .

In the Kerr case, given a set of values for (a, M) the parameters η and β are determined and can be treated as independent variables which may be used instead of a and M . In

the VEK case, there is a degeneracy in the 3-parameter family, however, which leads to the determination of only the angular momentum parameter a . To see this we express a and M in terms of η and β

$$\begin{aligned} a &= \eta\beta \\ M &= \frac{\eta(1 - \eta^2\beta^2/R^2)}{2\sqrt{(1 - \beta^2)(1 - \eta^2/R^2)}} \end{aligned} \quad (3.33)$$

We see that a is uniquely determined once η and β are given. But M is not since it depends on the background parameter R as well. Therefore, there is a whole family of stationary, axisymmetric black holes depending on R . We also note that the equation for the horizon can be expressed in terms of η and β as

$$R \sin(r_+/R) = \frac{\eta\sqrt{1 - \beta^2}}{1 - \eta^2\beta^2/R^2} \quad (3.34)$$

As we have seen above, the parameters η and β are inherent to the geometry of the black hole. It is instructive therefore to examine the variation of one of the parameters, say β , with the background. Here again we would have both the modulated and the direct effects. The variation of the other parameter η is easily ascertained from equation(3.33). Towards this end we express β in terms of M , a and R from equation(3.31) as

$$\beta = \frac{a\sqrt{(1 + (M + \sqrt{M^2 - a^2})^2/R^2)}}{\sqrt{2M(M + \sqrt{M^2 - a^2})}} \quad (3.35)$$

In Figure 3.3, the variation of β , with a is displayed for different values of R ; this shows the modulating effect of the background. We see that smaller the background parameter R , larger is the rate of variation of β with a .

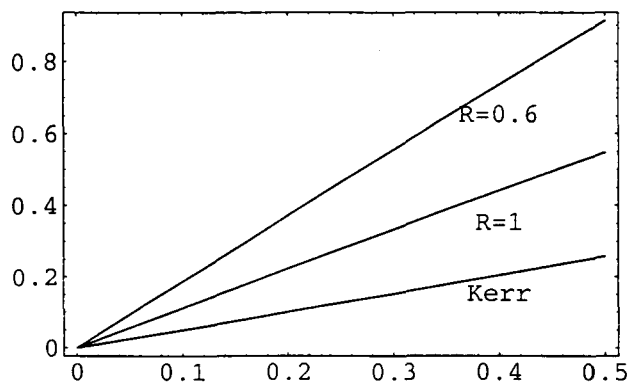

Figure 3.3: This plot shows the behaviour of the distortion parameter β with a for $M = 1$ and for different values of R including the Kerr case.

Turning to the direct effect, as can be seen, the plot of β against R in Figure 3.4 shows that β goes on increasing as the background parameter R decreases. That is, the distortion parameter goes up as the background influence increases. In particular, the minimum value

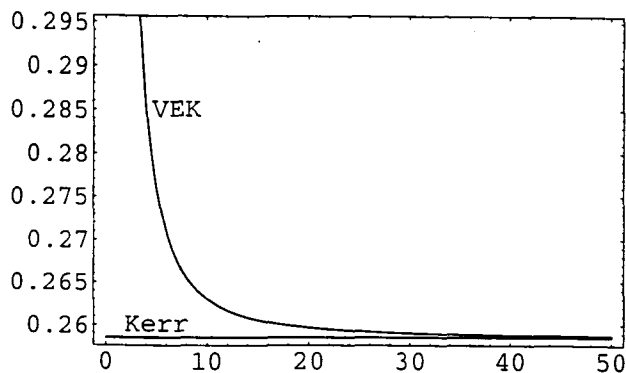

Figure 3.4: This plot shows the behaviour of the distortion parameter β with R for $M = 1$ and $a = 0.5$.

is attained for the limiting Kerr case.

One additional point to be considered is the allowable range of values for the scale and the distortion parameters. In the Kerr case, it is necessary and sufficient to demand that $a \leq M$. This places a restriction $\beta \geq 1/\sqrt{2}$, the equality holding for the case of the extreme Kerr black hole with $a = M$. In the VEK case, this generalizes to $a \leq M$ which is equivalent to the condition

$$\beta \geq \frac{1}{\sqrt{2}} \sqrt{1 + \frac{a^2}{R^2}} \quad (3.36)$$

In terms of the scale and the distortion parameters, we now study the equatorial and polar circumferences as well as the oblateness of the event horizon as a function of R .

Effect of the background on the circumferences via the scale and the distortion parameters.

The equatorial and polar circumferences C_e and C_p respectively are defined as follows.

$$\begin{aligned} C_e &= \int \theta^3 = \int_0^{2\pi} \sqrt{g_{\phi\phi}} d\phi \quad \text{at } \theta = \frac{\pi}{2} \\ C_p &= \int \theta^2 = \int_0^\pi \sqrt{g_{\theta\theta}} d\theta \end{aligned} \quad (3.37)$$

For the VEK event horizon we have

$$\begin{aligned} C_e &= \frac{2\pi\eta}{\sqrt{1-\beta^2}} \\ C_p &= \int_0^\pi \frac{\eta \sqrt{1-\beta^2 \sin^2 \theta}}{\sqrt{1-\eta^2 \beta^2 \sin^2 \theta / R^2}} d\theta \end{aligned} \quad (3.38)$$

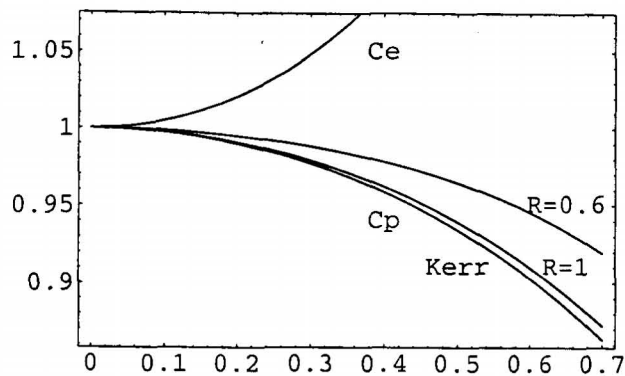

Figure 3.5: The equatorial and the polar circumferences plotted against β for different values of R .

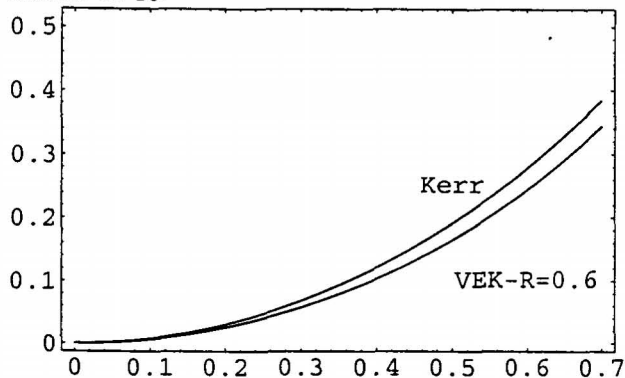

Figure 3.6: The oblateness parameter δ plotted against β for both the Kerr and the VEK cases.

Comparing these circumferences allows us to obtain a gross measure of the surface deformation. As in the Kerr case, both C_e and C_p are invariant since the curves are geodesics of the 2-metric of the horizon.

We may note that the expression for C_e is the same as that for the Kerr case, ie there is no explicit dependence of C_e on R . However, η and β are dependent on R .

As we have discussed at the beginning of this section, the variation of η and β could be due to the change in rotation for different fixed values of R . To compare the results with those of Smarr, we treat η and β as independent parameters and vary them for different fixed values of R . We compute C_e and C_p as functions of η and β for fixed values of R . The results are plotted in Figure 3.5. The equatorial circumference C_e , which does not depend explicitly on R and therefore, is the same for the VEK and Kerr cases, increases with β . However, the polar circumference decreases with β . For lower values of R , the rate of decrease of C_p is diminished compared to the Kerr case, showing that the flattening is reduced due to the background effect. The oblateness is reflected in the variation of $\delta = (C_e - C_p)/C_e$ which is shown in Figure 3.6. Once again the effect of the background is to decrease the oblateness generated by rotation.

The above calculations were carried out in order to apply Smarr's approach to the VEK metric. We now turn to the modulated and the direct effects of the background on C_e , C_p and δ to get further insight into the behaviour of the oblateness of the horizon.

Explicit effect of the background on the circumferences and the oblateness

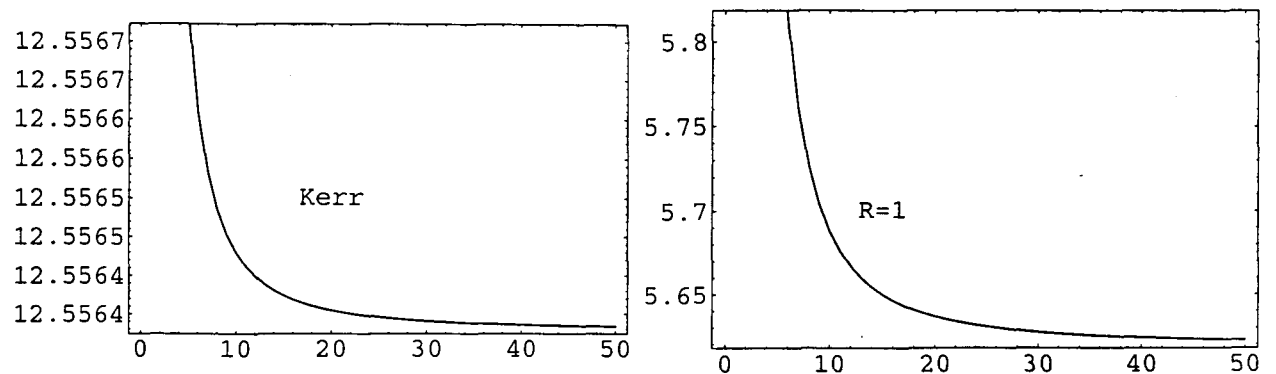

Figure 3.7: Plot of the equatorial circumference C_e against a^{-1} for $M = 1$ and for different values of R . Both the Kerr(left) and the VEK(right) cases are shown.

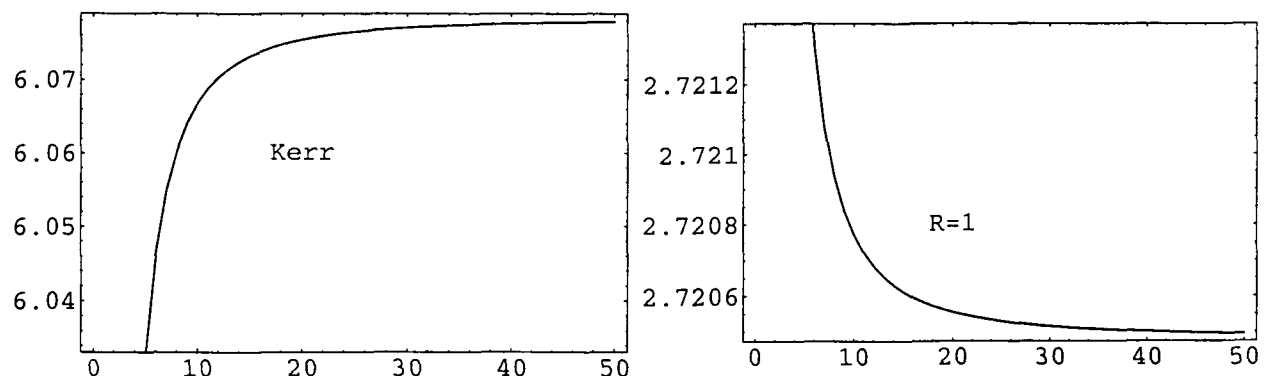

Figure 3.8: Plot of the polar circumference C_p against a^{-1} for $M = 1$ and for different values of R . For large values of R including the Kerr case(left), C_p decreases as a^{-1} decreases. After a critical value of R (not shown), C_p increases as a^{-1} decreases(right). Thus C_p is strongly modulated by the background.

We now express the circumferences in terms of the mass, angular momentum and the background parameter.

First we have the equatorial circumference

$$C_e = 2\pi \frac{\bar{\Sigma}_+}{\bar{\rho}_+} = \frac{2M(M + \sqrt{M^2 - a^2})}{1 + (M + \sqrt{M^2 - a^2})^2/R^2} \quad (3.39)$$

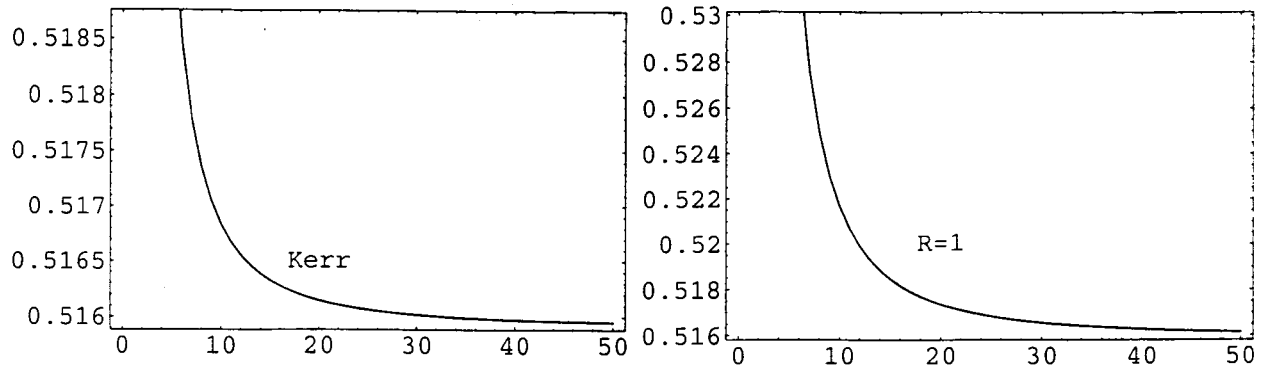

Figure 3.9: Plot of the oblateness parameter δ against a^{-1} for $M = 1$ and for different values of R . Both the Kerr(left) and the VEK(right) cases are shown.

And next the polar circumference

$$\begin{aligned}
 C_p &= \int_0^\pi \frac{\bar{\rho}_+}{\zeta} d\theta \\
 &= \int_0^\pi \frac{\sqrt{\left(1 - \frac{a^2 \sin^2 \theta}{R^2}\right) \left(M + \sqrt{M^2 - a^2}\right)^2 + a^2 \cos^2 \theta \left(1 + \left(M + \sqrt{M^2 - a^2}\right)^2 / R^2\right)^{-1}}{1 - a^2 \sin^2 \theta / R^2} d\theta
 \end{aligned} \tag{3.40}$$

In order to discern the modulated effect, these circumferences as well as the oblateness parameter δ are plotted against a^{-1} , instead of a for convenience, in Figures 3.7, 3.8 and 3.9 respectively, for different values of the background parameter R . The behaviour of the equatorial circumference C_e is uniform for all values of R including the limiting Kerr value, going up monotonically as a increases. However, the behaviour of the polar circumference C_p is not uniform for all values of R . For lower values of R , ie under strong background influence, C_p increases monotonically as a increases. This behaviour reverses at a critical value of R after which C_p decreases, as in the Kerr case, with increasing a . Therefore the effect of rotation is strongly modulated by the background parameter R . Nevertheless, the oblateness parameter δ increases uniformly for all values of R including the limiting Kerr value.

Thus the behaviour of the circumferences under the modulated effect may be summed up as follows. For large values of R , the horizon becomes oblate as the rotation increases, with the equatorial circumference increasing and the polar circumference decreasing with increase in rotation. Below a critical value of R , the horizon ‘bloats up’ as it were, with both the circumferences increasing with rotation accompanied by increased oblateness.

We now turn to the direct effect of the background on the circumferences. For this purpose, the circumferences as well as the oblateness parameter are plotted against R as shown in Figures 3.10 and 3.11 respectively. Both C_e and C_p decrease with R . This is due to the shrinkage of the event horizon which we had already anticipated in Section 3.2. The

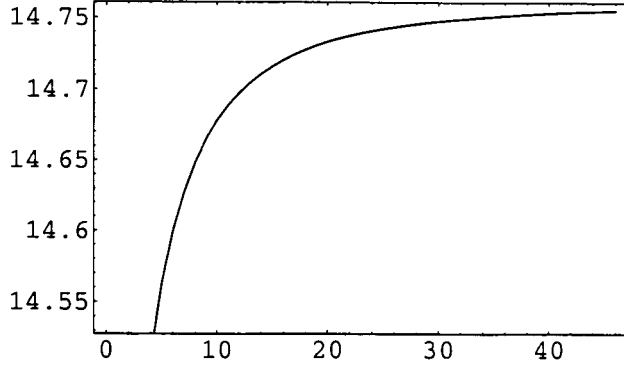

Figure 3.10: Plot of the equatorial circumference C_e against R for $M = 1$, $a = 0.5$.

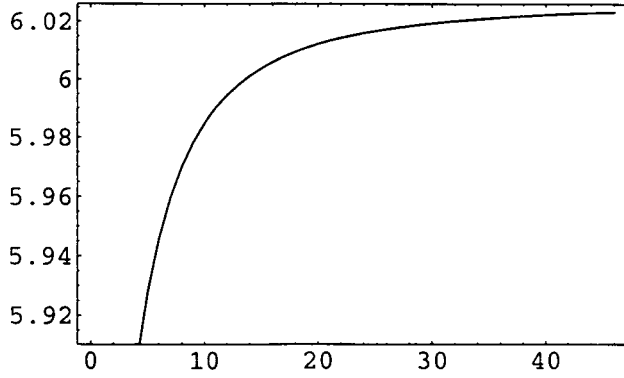

Figure 3.11: Plot of the polar circumference C_p against R for $M = 1$, $a = 0.5$.

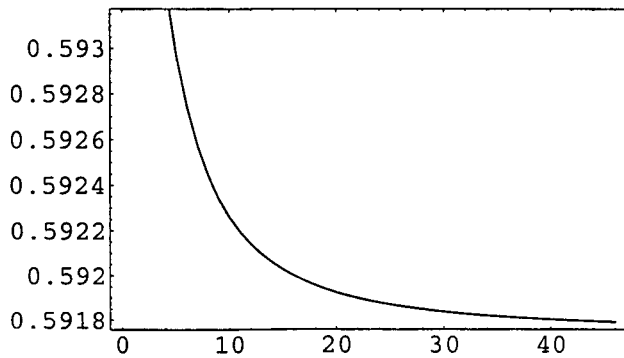

Figure 3.12: Plot of oblateness parameter δ against R for $M = 1$, $a = 0.5$. This illustrates the direct effect of the background on δ

oblateness is given by δ which is now an explicit function of R . The behaviour of δ with R is shown in Figure 3.12. Clearly, the effect of the background is to enhance the oblateness which increases with diminishing R .

In the Kerr case oblateness is caused only by rotation. Here we see that the non-flat background too contributes towards the oblateness by both modulated and direct effects.

We now consider another geometric quantity, the surface area of the event horizon.

3.4 The Surface Area

The surface area of the event horizon is an invariant geometric quantity of considerable importance. In a vacuum, asymptotically flat spacetime, it is a well established fact that Hawking's area theorem provides a starting point for black hole thermodynamics. This theorem states that the total surface area of a black hole can never decrease. We shall now examine the nature of the area in the VEK case.

In the Kerr case, the surface area of the horizon is given by

$$A_k = 8\pi M(M + \sqrt{M^2 - a^2}) \quad (3.41)$$

When we turn to the case of the VEK black hole, we find that the area

$$A = \int \theta^2 \wedge \theta^3 = \frac{4\pi M(M + \sqrt{M^2 - a^2})}{1 + \frac{(M + \sqrt{M^2 - a^2})^2}{R^2}} \int_0^\pi \frac{\sin \theta}{\sqrt{1 - \frac{a^2 \sin^2 \theta}{R^2}}} d\theta \quad (3.42)$$

This can be integrated to give

$$A = \frac{4\pi M(M + \sqrt{M^2 - a^2}) R}{1 + \frac{(M + \sqrt{M^2 - a^2})^2}{R^2}} \frac{1}{a} \tanh^{-1}\left(\frac{a}{R}\right) \quad (3.43)$$

3.4.1 Effect of the background on the area

It is interesting to study the effect of the background on the area of the event horizon.

First we consider the modulated effect of the background and study the variation of the area as a function of a for different constant values of R . The results are plotted in Figure 3.13. For large values of R starting from the limiting Kerr value, the area decreases monotonically with a . Below a critical range of values of R , however, the area first increases with a , attains a maximum and then decreases. For lower values of R the behaviour of the area entirely reverses. It now increases monotonically with a . This is something entirely unexpected. It indicates that there is a nontrivial coupling of the background spacetime

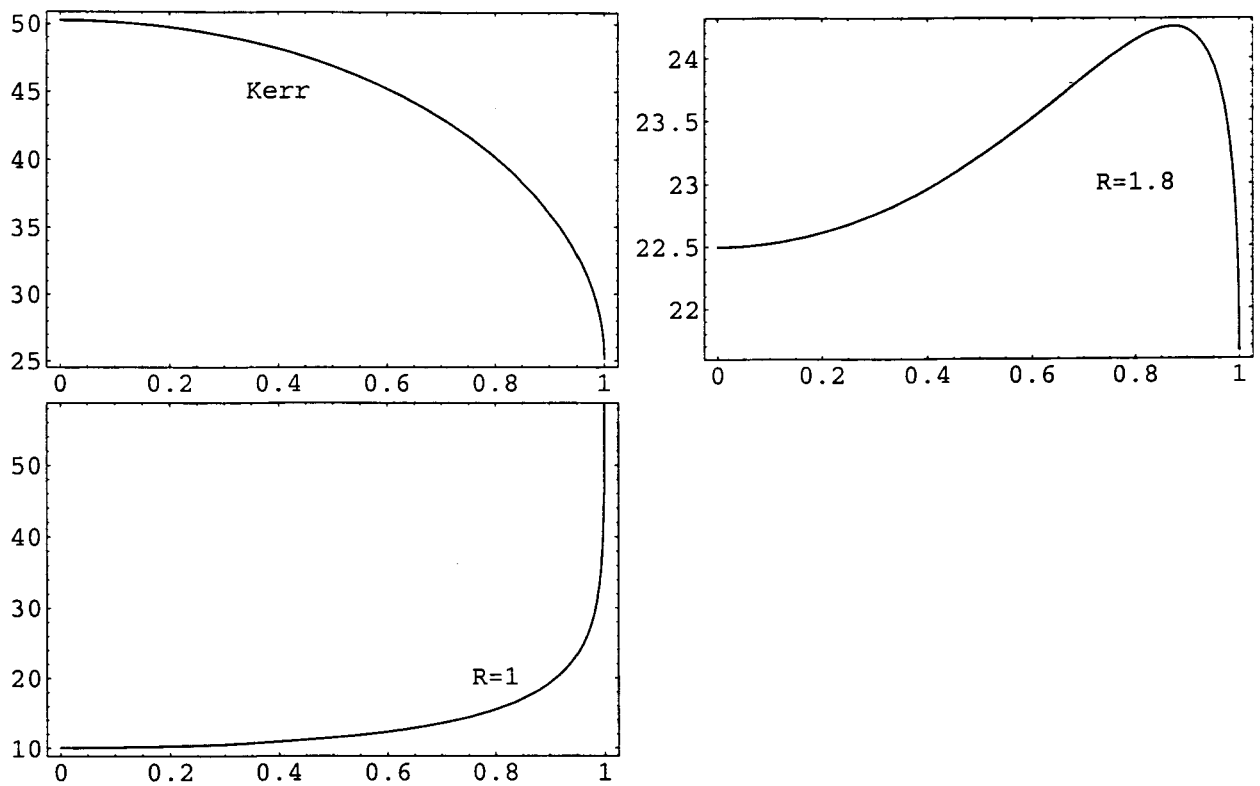

Figure 3.13: Plot of the area A against a for $M = 1$, for the Kerr case(top left) and for different values of R in the VEK case. For $R = 1.8$ (top right), A attains a maximum due to strong modulating effect of the background. After a critical range of values of R , the VEK area increases as a increases(bottom).

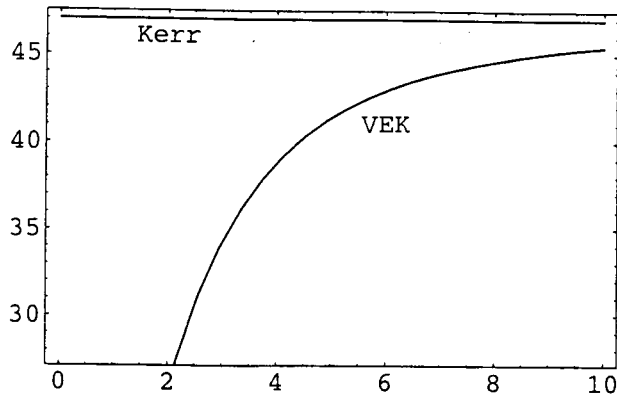

Figure 3.14: Plot of the area A against R for $M = 1$ and $a = 0.5$. Both the Kerr and the VEK cases are indicated. The decrease of the VEK area as R decreases, exhibits the direct effect of the background.

to rotation.

Turning to the direct effect of the background, the plot of the area against R in Figure 3.14 shows that it goes on decreasing as R decreases, that is, as the background influence increases. The area of the horizon goes down from its Kerr value at $R = \infty$ indicating the shrinkage of the horizon as was indicated by the polar diagrams of Figure 3.1.

3.5 Angular Velocity of the Horizon

The angular velocity of the Kerr black hole is constant over the horizon. This implies that the horizon rotates like a rigid body. This feature is of central importance in studying physical effects such as superradiance. It is also of direct interest in studying the effect of rotation on the black hole.

The angular velocity of the horizon of the VEK black hole is given by

$$\omega_H = \frac{a}{\bar{r}_+^2 + a^2} \quad (3.44)$$

As in the Kerr case, it is constant over the horizon of the VEK black hole. In terms of η and β , the angular velocity of the VEK horizon takes the simple form

$$\omega_H = \beta/\eta \quad (3.45)$$

In terms of M , a and R , the angular velocity of the horizon is

$$\omega_H = \frac{a(1 + (M + \sqrt{M^2 - a^2})^2/R^2)}{2M(M + \sqrt{M^2 - a^2})} \quad (3.46)$$

This shows that there is a significant increase in the angular velocity of the horizon as R decreases, that is as the background influence increases. This in turn indicates that there

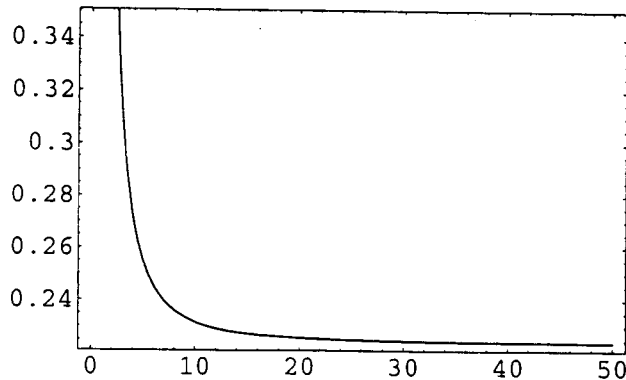

Figure 3.15: Plot of the angular velocity ω_H of the horizon against R for $M = 1$, $a = 0.5$. As R decreases, ω_H increases due to strong background influence.

would be a pronounced modification in the physical effects associated with the angular velocity of the horizon. The variation of ω_H with respect to R is plotted in Figure 3.15 and shows its sharp increase with decreasing R .

3.6 Surface Gravity and the Extreme VEK Black Hole

We now discuss the surface gravity of the VEK black hole and define the ‘extreme’ VEK black hole. The surface gravity of the VEK black hole is given by

$$\kappa_{vek} = \left(1 + \frac{M + \sqrt{M^2 - a^2}}{R^2}\right) \frac{M^2 - a^2}{2M(M + \sqrt{M^2 - a^2})} \quad (3.47)$$

This goes to zero when $a = M$. Therefore, in analogy with the Kerr case we may define the extreme VEK black hole as the VEK black hole corresponding to the case $a = M$. We now discuss the existence of yet another case for the VEK black hole.

In the Kerr case as discussed by Smarr[24](see also Carter[26]) we may define the equatorial surface velocity of the black hole by,

$$v := \sqrt{g_{33}}\omega_H \quad (3.48)$$

This reduces to

$$v = \frac{a}{M + \sqrt{M^2 - a^2}} \quad (3.49)$$

This tends to the velocity of light ($v \rightarrow 1$) as the extreme Kerr black hole is approached. In the VEK case, due to the absence of asymptotic flatness, it may not be possible to define the corresponding equatorial surface velocity of the black hole. Nevertheless, proceeding by analogy with the asymptotically flat case, we may use this ‘definition’ to obtain a classification of the VEK black hole. Thus, in the VEK spacetime the above formalism leads once again to

$$v_{vek} := \sqrt{g_{33}}\omega_H = \frac{a}{M + \sqrt{M^2 - a^2}} \frac{\sqrt{1 + (M + \sqrt{M^2 - a^2})^2/R^2}}{\sqrt{1 - a^2/R^2}} \quad (3.50)$$

The extreme VEK case $a = M$ gives

$$v_{vek} = \sqrt{1 + \frac{a^2}{R^2}} / \sqrt{1 - \frac{a^2}{R^2}} \quad (3.51)$$

This is clearly greater than unity. This makes it possible to classify the VEK black hole into two classes. One given by $v_{vek} < 1$ and the other given by $v_{vek} > 1$ as seen from outside by a Killing observer. The existence of the Killing observer is ensured because in the present, as in the asymptotically flat case, the norm of the timelike Killing vector is unity at the radius $r/R = \pi/2$ where the matching to the Einstein universe has been performed.

The value $v_{vek} = 1$ allows us to define the ‘limiting black hole’ for which

$$R = \frac{\sqrt{2}(M + \sqrt{M^2 - a^2})a}{\sqrt{2M(M + \sqrt{M^2 - a^2}) - 2a^2}} \quad (3.52)$$

This shows that for any given R there exists a set of values for a and M that generates a class of limiting black holes. We can see from the above equation that at $a = M$, $R = \infty$. As we have already stressed, the background parameter R represents the influence of the non-vacuum background which is asymptotically non-flat. $R = \infty$ corresponds to the limiting case of a vacuum background which is asymptotically flat. Therefore equation(3.52) which describes the limiting black hole contains, as a limiting case, the extreme black hole $a = M$ at which $R = \infty$. The analogue of the condition $a = M$ for an extreme black hole may now be expressed by an equivalent form of equation(3.52)

$$M = \frac{(1 - a^2/R^2)a}{\sqrt{1 - 2a^2/R^2}} \quad (3.53)$$

which goes over to the limiting case $a = M$ as $R \rightarrow \infty$

3.7 The Gaussian Curvature and Embedding

The Gaussian curvature defines an isometrically invariant local measure of the intrinsic distortion of the event horizon from sphericity. Being an invariant it provides us information about the topology of the horizon as well via the Gauss-Bonnet theorem. We may study the Gaussian curvature either by treating it as a function of the parameters η and β , or by treating it as an explicit function of the background parameter R .

The Gaussian curvature of the event horizon of the VEK black hole is given by

$$K = \frac{\bar{\Sigma}_+}{\bar{\rho}_+^6} \left(\left(1 + \frac{a^2 \cos^2 \theta}{R^2} \right) \bar{\rho}_+^2 - 4a^2 \zeta \cos^2 \theta \right) \quad (3.54)$$

which in terms of the scale and the distortion parameters, may be expressed as

$$K(\eta, \beta, \theta) = \frac{\sqrt{1 - \eta^2 \beta^2 \sin^2 \theta / R^2}}{\eta^2 (1 - \beta^2 \sin^2 \theta)^3} \left((1 + \eta^2 \beta^2 \cos^2 \theta / R^2) (1 - \beta^2 \sin^2 \theta) - 4\beta^2 \cos^2 \theta \sqrt{1 - \eta^2 \beta^2 \sin^2 \theta / R^2} \right) \quad (3.55)$$

When $\beta = 0$ ie when the rotation is absent, we have,

$$K = \frac{1}{\bar{r}_+^2} = \frac{1}{R^2 \sin^2(r/R)} \quad (3.56)$$

which is the spherical Gaussian curvature of the horizon of the VES black hole. And when $R \rightarrow \infty$ we have

$$K = \frac{\Sigma_+}{\rho_+^6} (\rho_+^2 - 4a^2 \cos^2 \theta) \quad (3.57)$$

the Gaussian curvature of the event horizon of the Kerr black hole.

In the Kerr case, K is a function of the polar angle θ . In the VEK case, K is in addition a function of the parameter R . The Gaussian curvature vanishes at the poles when

$$\beta = \frac{1}{2} \sqrt{1 + \frac{a^2}{R^2}} \quad (3.58)$$

which in turn happens for

$$M = \frac{2a\sqrt{1 - a^2/R^2}}{\sqrt{(1 - 3a^2/R^2)(3 - a^2/R^2)}} \quad (3.59)$$

For

$$\frac{1}{2} \sqrt{1 + \frac{a^2}{R^2}} < \beta \leq \frac{1}{\sqrt{2}} \sqrt{1 + \frac{a^2}{R^2}} \quad (3.60)$$

there are two ‘‘polar caps’’ where the Gaussian curvature becomes negative. This condition is obtained by examining the range of values of β for which the Gaussian curvature vanishes. It allows us to classify the VEK black holes into two distinct classes parametrized by a and R through the dependence on the value of β as given in the above equation. But unlike in the Kerr case ($R \rightarrow \infty$), each class gives in fact a whole family depending on both a and R . The first class, as in the Kerr case, consists of black holes with positive Gaussian curvature resembling oblately deformed spheres. The second class consists of black holes with negative Gaussian curvature. As Smarr has commented in the Kerr case, this class of negative Gaussian curvature is unlike any surface one can envision in our familiar 3-space. This is to be attributed to the presence of regions of negative Gaussian curvature both on and around the axis of symmetry, causing the surface to resemble a hybrid sphere and pseudosphere. By integrating the Gaussian curvature over the surface we find that the Euler characteristic of the horizon is 2. This establishes that the topology of the VEK black hole is that of a 2-sphere.

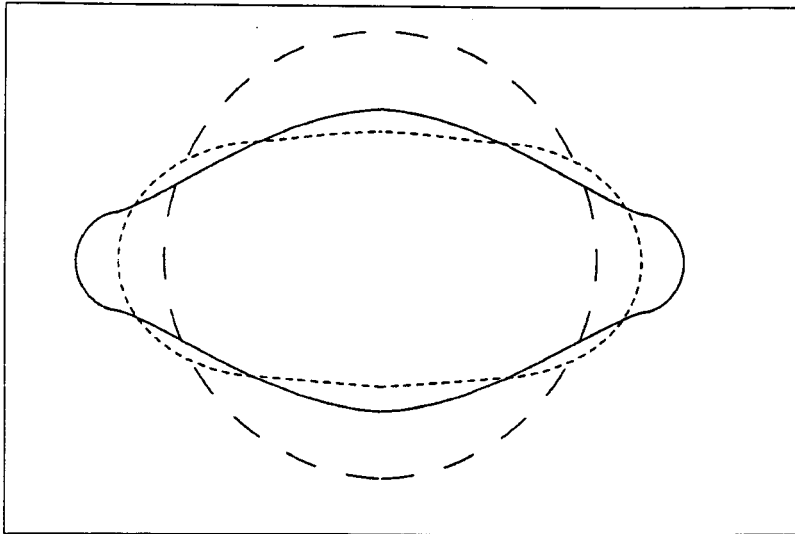

Figure 3.16: The sequence of embedding diagram for $\beta = 0$ (dashed line), $\frac{1}{2}\sqrt{1 + a^2/R^2}$ (dotted line), $\frac{1}{\sqrt{2}}\sqrt{1 + a^2/R^2}$ (solid line) shown for $a = 0.5$ and $R = 1$.

3.7.1 Embedding

Embedding the 2-surface of the VEK horizon in the Euclidean 3-space gives an additional visualization of the geometry. The possibility of embedding depends on the sign of the Gaussian curvature and may shed light on the nature of the surface under investigation. It is therefore instructive to find conditions for globally embedding the 2-surface of the VEK horizon. To this end we first rewrite the metric in the standard form

$$ds^2 = \eta^2 \left(\frac{1}{f(\mu)g(\mu)} + f d\phi^2 \right) \quad (3.61)$$

where

$$\begin{aligned} \mu &= \cos \theta \\ f &= \frac{(1 - \mu^2)}{1 - \beta^2(1 - \mu^2)} \\ g &= 1 - \frac{\beta^2 \eta^2 (1 - \mu^2)}{R^2} \end{aligned} \quad (3.62)$$

The Gaussian curvature is then given by

$$K(\mu) = \frac{-1}{2} \frac{\sqrt{g}}{\eta^2} (\sqrt{g} \ddot{f} + \frac{\dot{f} \dot{g}}{2\sqrt{g}}) \quad (3.63)$$

where the dot denotes differentiation with respect to μ .

We now define a map from (μ, ϕ) to (x, y, z) by

$$x = F(\mu) \cos \phi$$

$$\begin{aligned}y &= F(\mu) \sin \phi \\z &= G(\mu)\end{aligned}\tag{3.64}$$

The metric then becomes

$$ds^2 = dx^2 + dy^2 + dz^2 = (\dot{F}^2 + \dot{G}^2)d\mu^2 + F^2 d\phi^2\tag{3.65}$$

We now require that

$$\begin{aligned}\dot{F}^2 + \dot{G}^2 &= \frac{\eta^2}{fg} \\F^2 &= \eta^2 f\end{aligned}\tag{3.66}$$

from which we obtain

$$\begin{aligned}F &= \eta\sqrt{f} \\G &= \eta \int \frac{1}{f} \sqrt{1 - \frac{f^2}{4g}} d\mu\end{aligned}\tag{3.67}$$

The condition for global embedding is that the expression under the square root of the integrand be nonnegative definite. This leads to the result that the metric cannot be globally embedded in Euclidean 3-space if

$$\beta > \frac{1}{2} \sqrt{1 + \frac{a^2}{R^2}}\tag{3.68}$$

This is the same condition as for the negative curvature given by the inequality in equation(3.60).

The condition given by equation(3.68) is also equivalent to

$$M < \frac{2a\sqrt{1 - a^2/R^2}}{\sqrt{(1 - 3a^2/R^2)(3 - a^2/R^2)}}\tag{3.69}$$

The embedding diagram sequence for $\beta = 0, \frac{1}{2}\sqrt{1 + a^2/R^2}, \frac{1}{\sqrt{2}}\sqrt{1 + a^2/R^2}$ for $a = 0.5$ and $R = 1$ is shown in Figure 3.16. The first value of β corresponds to the VES black hole. For the second value, the polar region has negative curvature. The last value of β corresponds to the 'extreme' VEK black hole which, as we have shown, cannot exist. We have shown the diagram for this last value of β as an illustration only.

3.8 Concluding Remarks

In the present chapter we have investigated the Kerr black hole in the Einstein background given by Vaidya. This spacetime may be viewed as that of a rotating black hole surrounded by matter distribution satisfying reasonable energy conditions as we have demonstrated.

First of all we note that the VEK horizon is a Killing horizon as in the case of the Kerr spacetime. By studying the event horizon, we have shown that the background gives rise to significant modifications in the geometrical and physical quantities associated with the black hole. The event horizon shrinks from its limiting Kerr magnitude as the background influence increases and the stationary limit surface gets more distorted. Thus there is an enlargement of the ergosphere. The distortion of the horizon can be ascertained by computing its equatorial and polar circumferences and studying the variation of the oblateness parameter. The oblateness parameter δ is given by the difference of the equatorial and polar circumferences divided by the equatorial circumference. This has been investigated by two different approaches. In the first instance, to compare the results with those obtained by Smarr in the Kerr case, we vary the distortion parameter without varying the background parameter R . In this formalism the equatorial circumference remains the same as that of the Kerr horizon which of course varies with the distortion parameter. Nevertheless, the polar circumference progressively decreases but more slowly than in the Kerr case. The net effect is that the oblateness parameter increases more slowly as compared with the Kerr spacetime. In a sense, these computations reveal the variation of the oblateness modified by R and as compared with the Kerr horizon.

We have found that further insight can be gained into the structure of the horizon by investigating the oblateness as an explicit function of the parameters a and R . As we have pointed out there exist both modulated and direct effects.

The modulated effect is obtained by varying a for different fixed values of R . Here we have found a totally unexpected effect. That is, whereas the equatorial circumference C_e increases monotonically with a for all values of R , the polar circumference C_p first decreases as a increases, starting from the Kerr value, and then increases after a critical value of R . Nevertheless, the oblateness parameter increases with a for all values of R .

On the other hand the direct effect is obtained by varying R and studying the circumferences. Here, one sees that both C_e and C_p decrease as R decreases, ie as the background influence increases. However, the oblateness parameter increases as R decreases.

Another quantity that indicates the change in the geometry of the event horizon is its surface area. As was done in the case of the circumferences, we have studied two different effects of the background on the area. First the modulation of rotation by the background and second the direct effect of the background. In the first case, for large values of R the area decreases monotonically with a as in the Kerr case. Then for a critical range of values of R the area increases, attains a maximum and then decreases. Finally for small values of R it increases monotonically with a . This effect is also a novel one which reveals the peculiarity of the background influence. Next, we have the direct effect of the background. As R decreases thereby enhancing the background effect, the area decreases and asymp-

totically approaches the Kerr value as the background effect goes down.

Turning to the angular velocity of the VEK event horizon, we have shown that it goes up significantly as the background influence increases. By means of the surface gravity of the VEK horizon we have shown that the extreme VEK black hole occurs at $a = M$ as in the Kerr case. However the equatorial tangential velocity defined in analogy with the Kerr case is no longer that of light. By exploiting this fact, we have classified the VEK black hole and have shown that another type of black hole the 'limiting black hole' may be defined for which this velocity is that of light.

By investigating the intrinsic geometry as represented by the Gaussian curvature we have shown that the VEK black hole may be classified into two distinct classes. The first class consists of black holes with positive Gaussian curvature and the second consists of black holes with negative Gaussian curvature. In the Kerr case studied by Smarr, this classification is on the basis of two constant 'limiting' values of the distortion parameter β . In the VEK case however, the corresponding 'limiting' values are no longer constants but depend on the angular momentum parameter a and the background parameter R . The topology of the VEK event horizon is that of a 2-sphere as may be expected for any normal black hole.

To summarize, in this chapter we have considered a number of geometric properties as a function of the background parameter R . These properties are either *retained*, *modified* or *radically altered* as we have shown.

**BLACK HOLES
IN
COSMOLOGICAL BACKGROUNDS**

*A thesis
submitted for the degree of
Doctor of Philosophy
in the Faculty of Science
University of Calicut, India*

B. S. Ramachandra

**Indian Institute of Astrophysics
Bangalore, India**

March 2003

Chapter 4

Examples of Physical Effects in the VEK spacetime

4.1 Introduction

The stationary, axisymmetric, asymptotically flat Kerr black hole is associated with interesting and often intriguing physical effects. In particular we may mention the effects stemming from the presence of the ergoregion like the Penrose process and superradiance. Here the geometry of the event horizon plays an important role. The other, perhaps more observationally significant physical effects, are those associated with geodesics and the phenomenon of gyroscopic precession. A great deal of work has been done on both these topics in the asymptotically flat case. However, as we have pointed out and shown in the previous chapters, the introduction of the non-flat background leads to nontrivial modifications of the results obtained in the flat case. In the Chapter 3, we investigated the geometry of the event horizon and showed that many of the usual results were either strongly modulated or modified altogether by the presence of the non-flat background. Therefore it would be interesting and instructive to study some examples of physical effects in the VEK spacetime.

In the present chapter we investigate circular geodesics and gyroscopic precession in the VEK spacetime as examples of physical effects. In studying circular geodesics there are two approaches which are usually taken in the Kerr case. One is the geodesic Lagrangian method and the other the method of Killing vectors. The former is convenient when one wishes to express the results in terms of conserved quantities, the energy and the azimuthal angular momentum. The latter, perhaps faster and elegant, is that of the method of Killing vectors which leads one directly to the Keplerian frequency. In the Kerr case either of the two may be employed to obtain information on the circular geodesics. In the VEK case, however, due to the complicated nature of the intermediate expressions, we find it convenient to combine the above methods and use them in conjunction. In particular, we use the method of Killing vectors in order to obtain the Keplerian frequency and conditions for the existence of non-spacelike circular geodesics. We then use the geodesic Lagrangian

method to express these conditions in terms of the energy and the azimuthal angular momentum or the impact parameter. This also makes it easier to compare the results with the corresponding special case of the VES non-rotating spacetime.

Turning to gyroscopic precession in the VEK spacetime we approach it by employing the Frenet-Serret framework developed by Iyer and Vishveshwara[20]. Starting with a brief outline of the formalism, we apply it to the globally timelike Killing trajectories followed by stationary observers in the VEK spacetime. Next we study gyroscopic precession along circular orbits with constant angular speeds by using rotating coordinates. Armed with the above results we go on to investigate the generalized versions of the Schiff precession, precession in the VES spacetime, the Fokker-De Sitter precession and the Thomas precession in the the Einstein universe. We compare and contrast the results with the asymptotically flat case and show how the non-flat background leads to significant non-trivial modifications from the corresponding flat results.

4.2 Circular Geodesics

The study of circular geodesics is a significant topic in both Newtonian gravitation and general relativity. In the former it leads to the Kepler laws. In the latter it becomes even more important especially in black hole spacetimes wherein the Newtonian effects are considerably modified. In our investigations on circular geodesics in the VES spacetime in Chapter 2 we saw the emergence of novel features due to the asymptotically non-flat background. We now study circular geodesics in the rotating case namely in the VEK spacetime.

4.2.1 The metric

In the previous chapter we have presented the VEK metric and discussed its features in detail. Here, for the sake of reference, we recall that the metric in the generalized Boyer-Lindquist form is given by

$$ds^2 = \left(1 - \frac{2Mr}{\bar{\rho}^2}\right)dt^2 - \frac{\bar{\rho}^2}{\bar{\Delta}}dr^2 - \frac{\bar{\rho}^2}{\zeta^2}d\theta^2 - \frac{\sin^2\theta}{\bar{\rho}^2}\bar{\Sigma}^2d\phi^2 + 2\left(\frac{2Mra\sin^2\theta}{\bar{\rho}^2}\right)dtd\phi \quad (4.1)$$

where

$$\begin{aligned} \bar{r}^2 &= (R^2 - a^2) \sin^2\left(\frac{r}{R}\right), \\ r &= R \sin\left(\frac{r}{R}\right) \cos\left(\frac{r}{R}\right) \\ \bar{\rho}^2 &= \bar{r}^2 + a^2 \cos^2\theta \\ \bar{\Delta} &= \bar{r}^2 + a^2 - 2Mr \\ \bar{\Sigma}^2 &= (\bar{r}^2 + a^2)^2 - a^2 \sin^2\theta \bar{\Delta}, \end{aligned}$$

$$\zeta^2 = 1 - \frac{a^2 \sin^2 \theta}{R^2}. \quad (4.2)$$

In the above we impose $R > a$ to ensure the regularity of the metric coefficients. We now study circular geodesics by the method of Killing vectors[20].

4.2.2 The method of Killing vectors

The VEK metric admits a time-like Killing vector ξ^a and a rotational Killing vector η^a .

$$\begin{aligned} \xi^a &= (1, 0, 0, 0) \\ \eta^a &= (0, 0, 0, 1) \end{aligned} \quad (4.3)$$

The combination,

$$\chi^a = \xi^a + \omega \eta^a \quad (4.4)$$

is defined as a quasi-Killing vector if the Lie derivative of ω vanishes along χ

$$\mathcal{L}_\chi \omega = 0 \quad (4.5)$$

When ω is a constant χ^a reduces to a Killing vector field.

In order to investigate circular geodesics we adapt the four-velocity u^a along χ^a by writing

$$u^a = e^\psi \chi^a \quad (4.6)$$

we then have

$$\begin{aligned} e^{-2\psi} &= \chi^a \chi_a \\ \psi_{,a} \chi^a &= 0 \end{aligned} \quad (4.7)$$

Confining to the equatorial plane, we obtain by equating the derivative with respect to r of the norm $\chi^a \chi_a$ to zero, the generalized Keplerian frequency in the VEK spacetime

$$\omega = \frac{M}{Ma \pm \sqrt{\frac{M}{R \tan(r/R)} (R^2 - a^2) \sin^2(r/R)}} \quad (4.8)$$

The negative sign refers to the co-rotating orbit and the positive sign to the counter-rotating orbit.

The condition for the existence of null geodesics is obtained by demanding that

$$\chi^a \chi_a = 0 \quad (4.9)$$

This reduces to

$$\mp \frac{2Ma}{\sqrt{MR \tan(r/R)}} = ((1 - a^2/R^2)r - (1 + 2(1 - a^2/R^2) \cos^2(r/R))M) \quad (4.10)$$

For M going to zero, ie, in the Einstein universe,

$$\omega^2 = 0 \quad (4.11)$$

and there are no circular geodesics as is expected.

As $R \rightarrow \infty$ ie, in the limit of the Kerr spacetime, we obtain the Keplerian frequencies for the co and counter-rotating orbits

$$\omega = \frac{1}{a \pm \sqrt{\frac{r^3}{M}}} \quad (4.12)$$

And equation (4.10) becomes

$$\mp 2Ma\sqrt{\frac{r^3}{M}} = r^2(r - 3M) \quad (4.13)$$

This is the condition for the existence of null circular geodesics in the Kerr spacetime as discussed in Rindler and Perlick[27].

And in the limit $a \rightarrow 0$ of the VEK spacetime, we obtain the generalized Keplerian frequency

$$\omega = \sqrt{M/(R^3 \sin^3(\frac{r}{R}) \cos(\frac{r}{R}))} \quad (4.14)$$

Equation(4.10) now becomes

$$R \tan(r/R) = \frac{6M}{1 \pm \sqrt{1 - \frac{12M^2}{R^2}}} \quad (4.15)$$

This is the condition for the existence of null geodesics in the VES spacetime. The time-like geodesics are present within the limits given by the positive and negative roots of the equation as shown by Ramachandra and Vishveshwara[21].

Returning to the inequality(4.10) we may note that the null circular geodesics exist between the two limits

$$\mp \frac{2Ma}{\sqrt{MR \tan(r/R)}} = ((1 - a^2/R^2)r - (1 + 2(1 - a^2/R^2) \cos^2(r/R))M) \quad (4.16)$$

and the timelike geodesics exist between these two limits. In the VES case we have the corresponding equation(4.14) for $R \tan(r/R)$. To obtain a similar equation for the VEK case, it is necessary to solve equation(4.16) which is not easy. Therefore we now resort to the geodesic Lagrangian approach in order to obtain an equivalent equation for $R \tan(r/R)$ expressing the condition for the existence of null circular geodesics.

4.2.3 The geodesic Lagrangian

The equations governing the geodesics in a spacetime with the line element

$$ds^2 = g_{ab}dx^a dx^b \quad (4.17)$$

can be derived from the Lagrangian,

$$\mathcal{L} = \frac{1}{2} \left(\frac{ds}{d\tau} \right)^2 \quad (4.18)$$

as, for instance, given in Chandrasekhar[17] which we will follow in the discussion below. Here τ is an affine parameter which is usually identified with the proper time for time-like geodesics.

For the VEK spacetime, the geodesic Lagrangian is given by

$$2\mathcal{L} = \left(1 - \frac{2Mr}{\bar{\rho}^2}\right) \dot{t}^2 - \frac{\bar{\rho}^2}{\Delta} \dot{r}^2 - \frac{\bar{\rho}^2}{\zeta^2} \dot{\theta}^2 - \frac{\sin^2 \theta}{\bar{\rho}^2} \Sigma^2 \dot{\phi}^2 + 2 \left(\frac{2Mr a \sin^2 \theta}{\bar{\rho}^2} \right) \dot{t} \dot{\phi} \quad (4.19)$$

where the dot denotes differentiation with respect to τ .

In the equatorial plane defined by $\theta = \pi/2$ we have

$$2\mathcal{L} = \left(1 - \frac{2M}{R \tan(r/R)}\right) \dot{t}^2 - \frac{\bar{r}^2}{\Delta} \dot{r}^2 - \left((\bar{r}^2 + a^2 + \frac{2Ma^2}{R \tan(r/R)}) \right) \dot{\phi}^2 + 2 \left(\frac{2Ma}{R \tan(r/R)} \right) \dot{t} \dot{\phi} \quad (4.20)$$

The above Lagrangian has two conserved quantities coming from the cyclic coordinates t and ϕ , defined by

$$\left(1 - \frac{2M}{R \tan(r/R)}\right) \dot{t} + \frac{2Ma}{R \tan(r/R)} \dot{\phi} = E \quad (4.21)$$

the energy and

$$-\frac{2Ma}{R \tan(r/R)} \left(\dot{t} + (\bar{r}^2 + a^2) + \frac{2Ma^2}{R \tan(r/R)} \right) \dot{\phi} = L_z \quad (4.22)$$

the azimuthal angular momentum.

These quantities could also have been obtained by the method of Killing vectors but the present method is convenient in arriving at the differential equation for the radial coordinate.

Using the equations(4.21) and (4.22) we obtain the geodesic Hamiltonian for null geodesics as

$$2\mathcal{H} = E\dot{t} - L\dot{\phi} - \frac{\bar{r}^2}{\Delta} \dot{r}^2 = 0 \quad (4.23)$$

We now invert equations(4.21) and (4.22) to obtain

$$\dot{t} = \frac{1}{\Delta} \left(\left(1 - \frac{2M}{R \tan(r/R)}\right) L + \frac{2Ma}{R \tan(r/R)} E \right) \quad (4.24)$$

and

$$\dot{\phi} = \frac{1}{\Delta} \left((\bar{r}^2 + a^2 + \frac{2Ma^2}{R \tan(r/R)}) E - \frac{2Ma}{R \tan(r/R)L} \right) \quad (4.25)$$

Inserting these into equation(4.23) and simplyfing, we get

$$\dot{r}^2 = E^2 + \frac{2M}{R \tan(r/R)(R^2 - a^2) \sin^2(r/R)} (L - aE)^2 - \frac{1}{(R^2 - a^2) \sin^2(r/R)} (L^2 - a^2 E^2) \quad (4.26)$$

which may be written in terms of the impact parameter $D = L/E$ as

$$\dot{r}^2 = E^2 + \frac{2M}{R \tan(r/R)(R^2 - a^2) \sin^2(r/R)} (D - a)^2 E^2 - \frac{1}{(R^2 - a^2) \sin^2(r/R)} (D^2 - a^2) E^2 \quad (4.27)$$

Circular geodesics are defined by equating the above equation and its derivative to zero. We thus obtain

$$1 + \frac{2M}{R \tan(r/R)(R^2 - a^2) \sin^2(r/R)} (D - a)^2 - \frac{1}{(R^2 - a^2) \sin^2(r/R)} (D^2 - a^2) = 0 \quad (4.28)$$

And

$$\frac{2M}{R^2(R^2 - a^2) \sin^2(r/R)} (-csc^2(r/R) - 2cot^2(r/R))(D - a)^2 E^2 + \frac{2}{R(R^2 - a^2) \sin^2(r/R) \tan(r/R)} (D^2 - a^2) E^2 = 0 \quad (4.29)$$

Solving the above equation we obtain the condition for the existence of the circular null geodesics as

$$R \tan(r/R) = \frac{6M \frac{(D-a)}{(D+a)}}{1 \pm \sqrt{1 - \frac{12M^2 (D-a)^2}{R^2 (D+a)^2}}} \quad (4.30)$$

This is the generalized version and analogue of the equation(4.15) corresponding to the VES case. As $a \rightarrow 0$ we see that this reduces to equation(4.14).

Equations(4.16) and (4.30) express the condition for existence of null circular geodesics. These together with the generalized Keplerian frequency(4.8) completely characterize the timelike and null circular geodesics. In fact, these null geodesics are members of the principal null congruences confined to the equatorial plane. We now discuss the nature of the circular geodesics in some detail.

There are two possible cases of timelike and null circular geodesics in the VEK spacetime depending on the background parameter. This radical departure from the situation in the Kerr spacetime is due to the presence of the Einstein universe to which the Vaidya sector

has been matched.

The first case is defined by

$$R^2 > 12M^2 \frac{(D-a)^2}{(D+a)^2} \quad (4.31)$$

In this case null circular geodesics exist at the two limits of $R \tan(r/R)$ given by equation(4.10).

The inner null circular geodesic is defined by

$$R \tan(r/R) = \frac{6M \frac{(D-a)}{(D+a)}}{1 + \sqrt{1 - \frac{12M^2}{R^2} \frac{(D-a)^2}{(D+a)^2}}} \quad (4.32)$$

The outer null circular geodesic is defined by

$$R \tan(r/R) = \frac{6M \frac{(D-a)}{(D+a)}}{1 - \sqrt{1 - \frac{12M^2}{R^2} \frac{(D-a)^2}{(D+a)^2}}} \quad (4.33)$$

Timelike circular geodesics exist sandwiched between these two null geodesics.

In contrast to this the Kerr spacetime has only one photon orbit at $r = 3M \frac{(D-a)}{(D+a)}$ and the timelike circular geodesics exist starting from this value all the way up to infinity.

The second case is defined by

$$R^2 = 12M^2 \frac{(D-a)^2}{(D+a)^2} \quad (4.34)$$

In this case the null circular geodesics exist at only one value of $R \tan(r/R)$ given by

$$R \tan(r/R) = 6M \frac{(D-a)}{(D+a)} \quad (4.35)$$

And there are no timelike geodesics at all. We may understand this situation by considering the limit $R^2 \rightarrow 12M^2 \frac{(D-a)^2}{(D+a)^2}$ in equation(4.30). As this limit is approached the distance between the inner and outer null circular geodesics of the first case goes on decreasing. Thus the inner and outer geodesics approach and merge. Since timelike geodesics are confined between the inner and outer geodesics, as the limit is reached they disappear leaving the possibility of occurrence of only null circular geodesics at $R \tan(r/R) = 6M \frac{(D-a)}{(D+a)}$.

As mentioned earlier there are both co and counter rotating orbits at the value of $R \tan(r/R)$ given by equation(4.30). Therefore it is necessary to distinguish the cases $a < 0$, $a = 0$ and $a > 0$ as, for instance, done in the Kerr spacetime investigated in Chandrasekhar[17]

which we shall follow here. In the Kerr spacetime one determines the impact parameter D for these values of a . To do a similar analysis in the VEK case it is necessary to solve equations(4.28) and (4.29) simultaneously which is difficult for the case where $a \neq 0$. Nevertheless, we shall take the limit $a = 0$ and obtain further information on the VES case. Perhaps, the cases $a < 0$ and $a > 0$ can be tackled numerically which, however, we shall not attempt here.

For $a = 0$ equation(4.10) becomes

$$R \tan(r/R) = \frac{6M}{1 \pm \sqrt{1 - \frac{12M^2}{R^2}}} \quad (4.36)$$

Solving equations(4.28) and (4.29) together for $a = 0$ we obtain

$$D = \frac{3\sqrt{2}M}{\left(1 + \frac{12M^2}{R^2} \pm \sqrt{1 - \frac{12M^2}{R^2}}\right)^{1/2} \left(1 - \frac{1}{3} \left(1 \pm \left(\sqrt{1 - \frac{12M^2}{R^2}}\right)\right)\right)^{1/2}} \quad (4.37)$$

Here we must consider the cases $R^2 > 12M^2$ and $R^2 = 12M^2$.

For $R^2 > 12M^2$ there are two null circular geodesics. The inner corresponding to the positive sign and the outer to the negative sign. For $R^2 \gg 12M^2$ we may obtain the following approximate results.

The inner null circular geodesic with

$$D = \frac{3\sqrt{3}M}{\sqrt{\left(1 + \frac{3M^2}{R^2}\right)} \sqrt{1 - \frac{6M^2}{R^2}}} \quad (4.38)$$

This tends to $3\sqrt{2}$ as $R \rightarrow \infty$.

And the outer null circular geodesic with

$$D = \frac{R}{\sqrt{1 + \frac{2M^2}{R^2}}} \quad (4.39)$$

This tends to ∞ as $R \rightarrow \infty$.

For $R^2 = 12M^2$ we have

$$D = 3\sqrt{3/2} M \quad (4.40)$$

And there is only one photon orbit which occurs at $R \tan(r/R) = 6M$

We may summarize the situation as follows. In the Kerr case null geodesics occur at only one value of the radial coordinate, ie, at $r = 3M(D - a)/(D + a)$. There is one co and

one counter-rotating orbit corresponding to this value. In contrast to this, the VEK case we have two possibilities determined by the background parameter. In the first case, ie, for $R^2 > 12M^2 \frac{(D-a)}{(D+a)}$ null geodesics occur at two different values of $R \tan(r/R)$. Thus there are inner and outer photon orbits with one co and one counter-rotating orbit corresponding to each. Timelike geodesics exist sandwiched between the inner and the outer orbits. In the second case, ie, for $R^2 > 12M^2 \frac{(D-a)}{(D+a)}$ null circular geodesics occur at only one value of $R \tan(r/R)$. There is one co and one counter-rotating orbit corresponding to this. There is a total absence of timelike circular geodesics. This clearly illustrates that the presence of the nonflat background *radically alters* the nature of circular geodesics in the VEK spacetime.

In order to see other effects of the background we now turn our attention to the study of gyroscopic precession.

4.3 Gyroscopic Precession

The phenomenon of gyroscopic precession is an important example of rotational effects in black hole spacetimes. As shown by Iyer and Vishveshwara[20] this effect can be elegantly studied by employing the Frenet-Serret formalism. By means of this formalism we may exploit the invariant geometrical description of particle trajectories following the directions of spacetime symmetries represented by Killing vector fields. Once the Frenet-Serret formalism is adapted to characterize the Killing trajectories, the associated geometric parameters are identified with the physical characteristics of the trajectory. The curvature is identified with the particle acceleration and the first and the second torsions are directly related to the gyroscopic precession. The Frenet-Serret tetrad also serves as a convenient reference frame to describe physical phenomena. Here there are two approaches to take. In the first, by adapting the Frenet-Serret formalism to general timelike Killing vector fields, we may study the precession of a gyroscope with respect to a stationary observer. The precession is now due to the effect of the black hole rotation but as modified by the background.

Next, using the method of rotating coordinates the formalism can be adapted to the quasi-Killing trajectories defined in equation(4.5). The precession is now due to the effect of rotation of the black hole on the gyroscope moving in a circular trajectory as modified by the background. With this framework the gyroscopic precession can be investigated in various circumstances. We now briefly review the Frenet-Serret formalism. For details we refer to[20].

4.3.1 The Frenet-Serret formalism

We have already defined the quasi-Killing vector in the VEK spacetime in equations(4.4) to (4.7).

Introducing a tetrad $e_{(i)}^a$ with $i = 0, 1, 2, 3$ the Frenet-Serret equations may be written as

$$\begin{aligned}\dot{e}_{(0)}^a &= \kappa e_{(1)}^a \\ \dot{e}_{(1)}^a &= \kappa e_{(0)}^a + \tau_1 e_{(2)}^a \\ \dot{e}_{(2)}^a &= -\tau_1 e_{(1)}^a + \tau_2 e_{(3)}^a \\ \dot{e}_{(3)}^a &= -\tau_2 e_{(2)}^a\end{aligned}\quad (4.41)$$

where κ is the curvature and τ_1, τ_2 the first and second torsions respectively. From equations(4.6) and (4.7) we have

$$\dot{\kappa} = \dot{\tau}_1 = \dot{\tau}_2 = 0 \quad (4.42)$$

implying that along trajectories of χ^a the Frenet-Serret invariants κ, τ_1 and τ_2 are constants. We first apply this to the timelike Killing trajectories in the VEK spacetime.

4.4 Gyroscopic Precession Along Timelike Killing Trajectories

Writing the VEK metric for a stationary, axisymmetric spacetime expressed in generalized Boyer-Lindquist coordinates in a general form we have

$$ds^2 = g_{00}dt^2 + g_{11}dr^2 + g_{22}d\theta^2 + 2g_{03}dtd\phi + g_{33}d\phi^2 \quad (4.43)$$

The generalized Boyer-Lindquist coordinates are adapted to the Killing vectors ξ and η . As shown in reference[20], along trajectories of the timelike Killing vector ξ the the Frenet-Serret basis is given by

$$\begin{aligned}e_{(0)}^a &= \frac{1}{\sqrt{g_{00}}}(1, 0, 0, 0) \\ e_{(1)}^a &= -\frac{1}{2\kappa g_{00}}(0, g^{11}g_{00,1}, g^{22}g_{00,2}, 0) \\ e_{(2)}^a &= \frac{1}{\sqrt{g_{00}}\sqrt{-\Delta_3}}(-g_{03}, 0, 0, g_{00}) \\ e_{(3)}^a &= \frac{\sqrt{g^{11}g^{22}}}{2\kappa g_{00}}(0, -g_{00,2}, g_{00,1}, 0)\end{aligned}\quad (4.44)$$

where

$$\Delta_3 = g_{00}g_{33} - g_{03}^2 \quad (4.45)$$

The curvature and torsions are given by

$$\kappa^2 = -\frac{1}{4g_{00}^2}(g^{11}g_{00,1}^2 + g^{22}g_{00,2}^2) \quad (4.46)$$

$$\tau_1^2 = \frac{g_{03}^2}{4\Delta_3} \frac{(g^{ab}g_{00,a}(\ln \frac{g_{03}}{g_{00}})_{,b})^2}{(g^{ab}g_{00,a}g_{00,b})} \quad (4.47)$$

$$\tau_2^2 = \frac{1}{4\Delta_3 g_{11} g_{22}} \frac{(g_{00,1}g_{03,2} - g_{00,2}g_{03,1})^2}{(g^{ab}g_{00,a}g_{00,b})} \quad (4.48)$$

From equation(4.1) and the above we find that

$$\begin{aligned}
e_{(0)}^a &= \frac{1}{\sqrt{1 - \frac{2Mr}{\bar{\rho}^2}}}(1, 0, 0, 0) \\
e_{(1)}^a &= \frac{1}{\sqrt{\bar{\rho}^2(\bar{\Delta}\bar{\epsilon}^2 + 4\bar{r}^2 a^4 \sin^2 \theta \cos^2 \theta)}}(0, \bar{\Delta}\bar{\epsilon}, -2\bar{r}a^2 \sin \theta \cos \theta, 0) \\
e_{(2)}^a &= \frac{1}{\sin \theta \sqrt{\bar{\Delta}(1 - \frac{2Mr}{\bar{\rho}^2})}}(-\frac{2M\bar{r}a \sin^2 \theta}{\bar{\rho}^2}, 0, 0, (1 - \frac{2M\bar{r}}{\bar{\rho}^2})) \\
e_{(3)}^a &= \frac{1}{\sqrt{\frac{\bar{\rho}^2}{\bar{\Delta}}(\bar{\Delta}\bar{\epsilon}^2 + 4\bar{r}^2 a^4 \sin^2 \theta \cos^2 \theta)}}(0, 2\bar{r}a^2 \sin \theta \cos \theta, \bar{\epsilon}, 0)
\end{aligned} \tag{4.49}$$

and

$$\kappa^2 = \frac{M^2(\bar{\Delta}\bar{\epsilon}^2 + 4\bar{r}^2 a^4 \zeta^2 \cos^2 \theta \sin^2 \theta)}{(1 - \frac{2M\bar{r}}{\bar{\rho}^2})^2 \bar{\rho}^{10}} \tag{4.50}$$

$$\tau_1^2 = \frac{M^2 a^2 \bar{\Delta} \sin^2 \theta (\bar{\epsilon}^2 + 4\bar{r}a^2 \cos^2 \theta \zeta^2)}{(1 - \frac{2M\bar{r}}{\bar{\rho}^2})^2 \bar{\rho}^{10} (\bar{\Delta}\bar{\epsilon}^2 + 4\bar{r}^2 a^4 \zeta^2 \cos^2 \theta \sin^2 \theta)} \tag{4.51}$$

$$\tau_2^2 = \frac{4M^2 a^2 \bar{r}^2 \bar{\epsilon}^2 \cos^2 \theta}{\bar{\rho}^6 (\bar{\Delta}\bar{\epsilon}^2 + 4\bar{r}^2 a^4 \zeta^2 \cos^2 \theta \sin^2 \theta)} \tag{4.52}$$

where

$$\bar{\epsilon} \equiv \bar{r}^2 - a^2 \cos^2 \theta + 2a^2 \cos^2 \theta \sin^2(r/R) \tag{4.53}$$

Since κ is identified with the particle acceleration, the above equations(4.49-4.52) imply that in addition to being accelerated, the gyroscope carried by the stationary observer precesses with a non-zero angular velocity. This may be interpreted as a manifestation of the dragging of inertial frames in the VEK spacetime as modified by the background. To see the contribution from the background we examine the special case of an observer on the equatorial plane $\theta = \pi/2$. Equations(4.50-4.52) now become

$$\begin{aligned}
\kappa &= \frac{M\sqrt{\bar{\Delta}}}{(1 - \frac{2M\bar{r}}{\bar{r}^2}) \bar{r}^3} \\
&= \frac{M\sqrt{\bar{\Delta}}}{(1 - \frac{2MR \sin(r/R) \cos(r/R)}{(R^2 - a^2) \sin^2(r/R)})} (R^2 - a^2)^{3/2} \sin^3(r/R) \\
\tau_1 &= \frac{Ma}{\bar{r}^6} \left(1 - \frac{2M\bar{r}}{\bar{r}^2}\right) \\
&= \frac{Ma}{(R^2 - a^2)^3 \sin^6(r/R)} \left(1 - \frac{2MR \sin(r/R) \cos(r/R)}{(R^2 - a^2) \sin^2(r/R)}\right)
\end{aligned} \tag{4.54}$$

$$\tau_2 = 0 \tag{4.55}$$

That is, τ_1 is the only nonzero torsion.

Since the four-velocity is adapted to the timelike Killing vector field the basis vectors of the Frenet-Serret frame always remain oriented towards the stationary observers since they are Lie-dragged along the Killing trajectory. Thus the stationary observers will see the gyroscope precessing with an angular velocity per unit proper time given by $-\tau_1$. We shall return to this point after discussing the gyroscopic precession of an observer moving in a circular trajectory.

4.5 Rotating Coordinates and Gyroscopic Precession Along Circular Orbits

In Section 4.4, we have obtained κ, τ_1, τ_2 for an observer whose world line is along the integral curves of the timelike Killing vector ξ of a stationary spacetime. Such an observer is at a fixed value of r, θ and ϕ . We now use the method of rotating coordinates to adapt the expressions of Section 4.4 to trajectories belonging to a quasi-Killing congruence that represent observers moving along circular orbits with constant arbitrary angular speeds.

Taking the metric(4.43) adapted to the Killing vectors ξ and η we make a coordinate transformation

$$\begin{aligned}\phi &= \phi' + \omega t' \\ t &= t'\end{aligned}\tag{4.56}$$

under which the metric becomes

$$ds^2 = g_{0'0'} dt'^2 + 2g_{0'3'} d\phi' dt' + g_{3'3'} d\phi'^2 + g_{11} dr^2 + g_{22} d\theta^2\tag{4.57}$$

where

$$g_{0'0'} = g_{00} + 2\omega g_{03} + \omega^2 g_{33} \equiv \mathcal{A}\tag{4.58}$$

$$g_{0'3'} = g_{03} + \omega g_{33} \equiv \mathcal{B}\tag{4.59}$$

$$g_{3'3'} = g_{33}\tag{4.60}$$

Under this transformation the coordinate system is now adapted to $\xi' \equiv \xi + \omega\eta$ which is a Killing vector of this metric given by

$$\xi' = (1, 0, 0, 0)\tag{4.61}$$

We may now adapt the four-velocity along ξ' and obtain the curvature and the torsions along this world line. As ξ' now corresponds to $\xi + \omega\eta$ in the unprimed coordinates we can compute κ, τ_1 and τ_2 along trajectories $\xi + \omega\eta$ by replacing g_{00}, g_{03} and g_{33} in equations(4.50-4.52) by $g_{0'0'}, g_{0'3'}$ and $g_{3'3'}$. This procedure enables us to obtain the curvature and the torsions associated with an observer following circular trajectories. Along these orbits given

by trajectories of $\xi + \omega\eta$ the Frenet-Serret equations are given by

$$\begin{aligned} e_{(0)}^a &= \frac{1}{\sqrt{\mathcal{A}}}(1, 0, 0, \omega) \\ e_{(1)}^a &= -\frac{1}{2\kappa\mathcal{A}}(0, g^{11}\mathcal{A}_1, g^{22}\mathcal{A}_2, 0) \\ e_{(2)}^a &= \frac{1}{\sqrt{\mathcal{A}\sqrt{-\Delta_3}}}(\mathcal{B}, 0, 0, -C) \\ e_{(3)}^a &= \frac{\sqrt{g^{11}g^{22}}}{2\kappa\mathcal{A}}(0, -\mathcal{A}_2, \mathcal{A}_1, 0) \end{aligned} \tag{4.62}$$

$$\tag{4.63}$$

and the Frenet-Serret curvature and torsions are given by

$$\kappa^2 = -\frac{1}{4} \frac{(g^{11}\mathcal{A}_1^2 + g^{22}\mathcal{A}_2^2)}{\mathcal{A}^2} \tag{4.64}$$

$$\tau_1^2 = \frac{\mathcal{B}^2}{4\Delta_3(g^{11}\mathcal{A}_1^2 + g^{22}\mathcal{A}_2^2)} \left(\frac{g^{11}\mathcal{A}_1\mathcal{B}_1 + g^{22}\mathcal{A}_2\mathcal{B}_2}{\mathcal{B}} - \frac{g^{11}\mathcal{A}_1^2 + g^{22}\mathcal{A}_2^2}{\mathcal{A}} \right)^2 \tag{4.65}$$

$$\tau_2^2 = \frac{g^{11}g^{22}(\mathcal{A}_1\mathcal{B}_2 - \mathcal{A}_2\mathcal{B}_1)^2}{4\Delta_3\theta(g^{11}\mathcal{A}_1^2 + g^{22}\mathcal{A}_2^2)} \tag{4.66}$$

where

$$\begin{aligned} \mathcal{A}_a &= g_{00,a} + \omega^2 g_{33,a} \\ \mathcal{B}_a &= g_{03,a} + \omega g_{33,a} C = g_{00} + \omega g_{03} \end{aligned} \tag{4.67}$$

and the subscript a takes on values 1 and 2.

Explicitly, for the VEK spacetime the quantities \mathcal{A} , \mathcal{B} and \mathcal{C} are given by

$$\begin{aligned} \mathcal{A} &= 1 - \omega^2 \sin^2 \theta (\bar{r}^2 + a^2) - \frac{2M\underline{r}}{\bar{\rho}^2} (1 - a\omega \sin^2 \theta)^2 \\ \mathcal{B} &= \frac{2M\underline{r}a \sin^2 \theta}{\bar{\rho}^2} (1 - a\omega \sin^2 \theta) - (\bar{r}^2 + a^2)\omega \sin^2 \theta \\ \mathcal{C} &= 1 - \frac{2M\underline{r}}{\bar{r}^2} (1 - a\omega) \end{aligned} \tag{4.68}$$

and their derivatives with respect to r and θ are given by

$$\begin{aligned} \mathcal{A}_1 &= \frac{2M\bar{\epsilon}}{\bar{\rho}^4} (1 - a\omega \sin^2 \theta)^2 - 2(1 - a^2/R^2)\underline{r}\omega^2 \sin^2 \theta \\ \mathcal{A}_2 &= -2 \cos \theta \sin \theta (\bar{\Delta}\omega^2 + \frac{2M\underline{r}}{\bar{\rho}^4} ((\bar{r}^2 + a^2)\omega - a)^2) \\ \mathcal{B}_1 &= -2 \sin^2 \theta \left(\frac{M\bar{\epsilon}a(1 - a\omega \sin^2 \theta)}{\bar{r}^4} + (1 - a^2/R^2)\underline{r}\omega \right) \\ \mathcal{B}_2 &= \frac{4M\underline{r}a \sin \theta \cos \theta}{\bar{\rho}^2} \left(\frac{a^2 \sin^2 \theta (1 - a\omega \sin^2 \theta)}{\bar{\rho}^2} + (1 - 2a\omega \sin^2 \theta) \right) \\ &\quad - 2\omega \sin \theta \cos \theta (\bar{r}^2 + a^2) \end{aligned} \tag{4.69}$$

We now consider the gyroscopic precession by confining to the equatorial plane. Taking $\theta = \pi/2$ in the above equations we obtain

$$\begin{aligned}
A &= 1 - \omega^2(\bar{r}^2 + a^2) - \frac{2M\underline{r}}{\bar{r}^2}(1 - a\omega)^2 \\
B &= \frac{2M\underline{r}a}{\bar{r}^2}(1 - a\omega) - (\bar{r}^2 + a^2)\omega \sin^2 \theta \\
C &= 1 - \frac{2M\underline{r}}{\bar{r}^2}(1 - a\omega) \\
A_1 &= \frac{2M}{\bar{r}^2}(1 - a\omega)^2 - 2(1 - a^2/R^2)\underline{r}\omega^2 \\
A_2 &= 0 \\
B_1 &= -2 \left(\frac{M\underline{r}a(1 - a\omega)}{\bar{r}^2} + (1 - a^2/R^2)\underline{r}\omega \right) \\
B_2 &= 0
\end{aligned} \tag{4.70}$$

With these quantities we obtain the curvature and torsions as

$$\kappa^2 = \frac{\bar{\Delta}M^2 \left((a\omega - 1)^2 - \left(1 - \frac{a^2}{R^2}\right) \frac{\bar{r}^2 \underline{r} \omega^2}{M} \right)^2}{\bar{r}^6 \left(1 - (\bar{r}^2 + a^2)\omega^2 - \frac{2M\underline{r}(a\omega - 1)^2}{\bar{r}^2} \right)^2} \tag{4.71}$$

$$\tau_1^2 = \frac{1 \left(\frac{M\underline{r}a}{\bar{r}^2} - \left(\frac{\bar{r}^2 + 2a^2}{\bar{r}^2} M - \left(1 - \frac{a^2}{R^2}\right) \underline{r} \left(1 - \frac{2M}{\underline{r}}\right) \right) \omega + \frac{Ma(3\bar{r}^2 + a^2)\omega^2}{\bar{r}^2} \right)^2}{\bar{r}^2 \left(1 - (\bar{r}^2 + a^2)\omega^2 - \frac{2M(a\omega - 1)^2}{\underline{r}} \right)^2} \tag{4.72}$$

$$\tau_2^2 = 0. \tag{4.73}$$

We note that the gyroscopic precession is about $\mathbf{e}_{(3)}$ which is normal to the orbital plane and the precession frequency is given by τ_1 as above.

Geodesic motion and the Schiff precession.

Along a geodesic, $\kappa = 0$ and therefore the angular velocity ω is given by

$$\omega^2 = \frac{M}{Ma \pm \sqrt{\frac{M}{R \tan(r/R)} (R^2 - a^2) \sin^2(r/R)}} \tag{4.74}$$

which is just the generalized Keplerian frequency in the VEK spacetime already obtained in Section 4.2.

The only non-zero torsion τ_1 becomes

$$\begin{aligned}
\tau_1 &= \sqrt{\frac{M}{\bar{r}^2 R \tan(r/R)}} \\
&= \sqrt{\frac{M}{(R^2 - a^2) \sin^2(r/R) R \tan(r/R)}}
\end{aligned} \tag{4.75}$$

We see at once that a novel feature has emerged due to the presence of the background. In the Kerr case we have

$$\tau_{1(\text{Kerr})} = \sqrt{\frac{M}{r^3}} \quad (4.76)$$

This coincides with the Schwarzschild Keplerian frequency ω_s . The rotational effect of the Kerr black hole is in making the gyroscope following a circular trajectory, to precess with the Schwarzschild Keplerian frequency. There is no ‘direct effect’, in the sense defined in Chapter 3, of the black hole rotation on the gyroscope. This is evident from the absence of the angular momentum parameter in the expression for $\tau_{1(\text{Kerr})}$. In contrast to this, in the VEK case, the first torsion τ_1 does not coincide with the VES generalized Keplerian frequency given by

$$\omega_{\text{VES}} = \frac{M}{R^3 \sin^3(r/R) \cos(r/R)} \quad (4.77)$$

In fact $\tau_{1(\text{VEK})}$ is related to ω_{VES} as

$$\tau_1 = \frac{\cos^2(r/R)}{1 - \frac{a^2}{R^2}} \omega_{\text{VES}} \quad (4.78)$$

As $R \rightarrow \infty$, $\tau_{1(\text{VEK})} \rightarrow \omega_{\text{VES}}$ and the Kerr result is recovered. For values of a/R comparable to unity, however, $\tau_{1(\text{VEK})}$ no longer coincides with ω_{VES} and the relation is drastically affected.

Comparing this situation with the Kerr case we see that as the gyroscope moves along the circular geodesic its precession is affected not only indirectly by the black hole but also by the background through the parameter R . Moreover, R enters into the picture by coupling to the angular momentum parameter a . This implies that the effect of the background manifests itself in both modulated and direct effects in the sense elucidated in Chapter 3. We may recall that the ‘modulated effect’ is discerned by keeping the background parameter fixed and allowing the angular momentum parameter a to vary and the direct effect is discerned by holding a fixed and allowing R to vary. We now consider the gyroscopic precession in various circumstances.

The gyroscopic frequency $\mp|\tau_1|$ is about the basis $\mathbf{e}_{(3)}$ which is oriented along the z -direction. The orbiting(co-rotating) observer measures precession relative to the basis $\mathbf{e}_{(1)}$ which coincides with the radius vector which rotates with the angular velocity given by equation(4.10). The precession angle per unit time as evaluated in the rotating coordinates is

$$\begin{aligned} \Delta\phi' = & \\ \mp \frac{M}{\bar{r}^2 R \tan(r/R)} \sqrt{g_{0'0'}} \frac{2\pi}{|\omega|} = & \\ \mp 2\pi \left(\frac{(R^2 - a^2) \sin^2(r/R)}{R^2 \tan^2(r/R)} - \frac{M}{R \tan(r/R)} (1 + 2 \cos^2(r/R)) \pm 2a \sqrt{\frac{M}{R^3 \tan^3(r/R)}} \right)^{1/2} & \end{aligned} \quad (4.79)$$

Next, to evaluate the precession relative to a stationary geometry we subtract from the precession at the end of one revolution the angle through which $\mathbf{e}_{(1)}$ has rotated with respect to the stationary observer which is 2π radians. This gives the gyroscopic precession in the VEK spacetime.

$$\Delta\phi = \mp 2\pi \left(\left(\frac{(R^2 - a^2) \sin^2(r/R)}{R^2 \tan^2(r/R)} - \frac{M}{R \tan(r/R)} (1 + 2 \cos^2(r/R)) \pm 2a \sqrt{\frac{M}{R^3 \tan^3(r/R)}} \right)^{\frac{1}{2}} - 1 \right) \quad (4.80)$$

In the linear approximation this reduces to a generalized version of the Schiff precession.

Another interesting result is obtained by computing the precession of the orbiting gyroscope with respect to the gyroscope of the stationary observer. In the time taken for one revolution of the orbiting gyroscope the latter precesses due to dragging by an amount

$$\Delta\phi_{(\text{drag})} = (-\tau_1) \sqrt{g_{00}} \frac{2\pi}{|\omega|} \quad (4.81)$$

as has been discussed in [20] where τ_1 is given by equation (4.51). This leads to

$$\begin{aligned} \Delta\phi_{(\text{drag})} &= -\frac{2\pi M a}{(R^2 - a^2)^{3/2} \sin^3(r/R)} \left(\frac{(R^2 - a^2) \sin^2(r/R)}{\sqrt{M R \tan(r/R)}} \pm a \right) \\ &\times \left(1 - \frac{2MR \sin(r/R) \cos(r/R)}{(R^2 - a^2) \sin^2(r/R)} \right)^{-\frac{1}{2}} \end{aligned} \quad (4.82)$$

4.5.1 VES black hole

Since we have not considered gyroscopic precession in the VES spacetime in Chapter 2, we shall give it here as a special case.

The VES metric may be obtained from the VEK metric as a special case of $a = 0$. Thus the most general case of gyroscopic precession follows from the VEK expression for $a = 0$.

General VES case.

Taking $a = 0$ in equations (4.68-4.69) yields

$$\begin{aligned} \mathcal{A} &= 1 - \omega^2 \sin^2 \theta \bar{r}^2 - \frac{2M\bar{r}}{\bar{r}^2} \\ \mathcal{B} &= \bar{r}^2 \omega \sin^2 \theta \\ \mathcal{C} &= 1 - \frac{2M\bar{r}}{\bar{r}^2} \\ \mathcal{A}_1 &= \frac{2M}{\bar{r}^2} - 2\bar{r}\omega^2 \sin^2 \theta \end{aligned}$$

$$\begin{aligned}
\mathcal{A}_2 &= -2 \cos \theta \sin \theta \bar{r}^2 \omega^2 \\
\mathcal{B}_1 &= -2 \sin^2 \theta \omega \underline{r} \\
\mathcal{B}_2 &= -2 \omega \sin \theta \cos \theta \bar{r}^2
\end{aligned} \tag{4.83}$$

The curvature and torsions are given by

$$\kappa^2 = \frac{\left(1 - \frac{2M}{R \tan(r/R)}\right) \left(\frac{M}{\bar{r}^2} - \underline{r} \omega^2 \sin^2 \theta\right)^2 + \bar{r}^2 \omega^4 \sin^2 \theta \cos^2 \theta}{\left(1 - \frac{2M}{R \tan(r/R)} - \bar{r}^2 \omega^2 s^2\right)^2} \tag{4.84}$$

$$\begin{aligned}
\tau_1^2 &= \\
&\omega^2 \sin^2 \theta \times \\
&\frac{\left(1 - \frac{2M}{R \tan(r/R)}\right) \left(\frac{M \underline{r}}{\bar{r}^4} - \omega^2 \sin^2 \theta \cos^2(r/R)\right) \left(1 - M\left(\frac{1}{\underline{r}} + \frac{2\underline{r}}{\bar{r}^2}\right) - \omega^2 c^2\right)^2}{\left(1 - \frac{2M}{R \tan(r/R)} - \bar{r}^2 \omega^2 \sin^2 \theta\right)^2 \left(\left(1 - \frac{2M}{R \tan(r/R)}\right) \left(\frac{M}{\bar{r}^3} - \omega^2 \sin^2 \theta \cos^2(r/R)\right)^2 + \omega^4 \sin^2 \theta \cos^2 \theta\right)} \\
\tau_2^2 &= \frac{\omega^2 M^2 \cos^2 \theta}{\bar{r}^6 \left(\left(1 - \frac{2M}{R \tan(r/R)}\right) \left(\frac{M}{\bar{r}^3} - \omega^2 \sin^2 \theta \cos^2(r/R)\right)^2 + \omega^4 \sin^2 \theta \cos^2 \theta\right)}
\end{aligned} \tag{4.85}$$

The Frenet-Serret frame is given by

$$\begin{aligned}
e_{(0)}^a &= \frac{1}{\sqrt{1 - \frac{2M \underline{r}}{\bar{r}^2} - \bar{r}^2 \omega^2 \sin^2 \theta}} (1, 0, 0, \omega) \\
e_{(1)}^a &= \frac{1}{\left(\left(1 - \frac{2M}{R \tan(r/R)}\right) \left(\frac{M}{\bar{r}^2} - \underline{r} \omega^2 \sin^2 \theta\right)^2 + \bar{r}^2 \omega^4 \sin^2 \theta \cos^2 \theta\right)^{1/2}} \\
&\times \left(0, \left(1 - \frac{2M}{R \tan(r/R)}\right) \left(\frac{M}{(R \tan(r/R))^3} - \omega^2 \sin^2 \theta\right), \frac{\omega^2 \cos \theta \sin \theta}{R \tan(r/R)}, 0\right) \\
e_{(2)}^a &= \frac{1}{\underline{r} \sin \theta \sqrt{\left(1 - \frac{2M}{R \tan(r/R)}\right) \left(1 - \frac{2M}{R \tan(r/R)} - \omega^2 \bar{r}^2 \sin^2 \theta\right)}} \left(\omega \bar{r}^2 \sin^2 \theta, 0, 0, -\left(1 - \frac{2M}{R \tan(r/R)}\right)\right) \\
e_{(3)}^a &= \frac{\sqrt{1 - \frac{2M}{R \tan(r/R)}}}{\underline{r} \left(\left(1 - \frac{2M}{R \tan(r/R)}\right) \left(\frac{M \underline{r}}{\bar{r}^4} - \omega^2 \sin^2 \theta\right)^2 + \omega^4 \cos^2 \theta \sin^2 \theta\right)^{1/2}} \\
&\times \left(0, \cos \theta \sin \theta \underline{r} \omega^2, \frac{M \underline{r}}{\bar{r}^3} - \omega^2 \sin^2 \theta, 0\right)
\end{aligned} \tag{4.86}$$

The equatorial plane.

As is usual we compute the precession for orbits in the equatorial plane for which $\theta = \pi/2$. Equations(4.84-4.85) reduce when $\theta = \frac{\pi}{2}$ to

$$\kappa^2 = \frac{\bar{r}^2 \left(1 - \frac{2M}{R \tan(r/R)}\right) \left(\frac{M}{\bar{r}^3} - \omega^2 \cos^2(r/R)\right)^2}{\left(1 - \frac{2M}{R \tan(r/R)} - \bar{r}^2 \omega^2\right)^2} \tag{4.87}$$

$$\tau_1^2 = \omega^2 \frac{\left(1 - M\left(\frac{1}{\underline{r}} + \frac{2\underline{r}}{\bar{r}^2}\right)\right)^2 \cos^2(r/R)}{\left(1 - \frac{2M}{R \tan(r/R)} - \bar{r}^2 \omega^2\right)^2} \tag{4.88}$$

$$\tau_2^2 = 0 \tag{4.89}$$

The bases vectors of the Frenet-Serret frame are obtained by inserting $\theta = \pi/2$ in equation(4.86). The gyroscopic precession in this case is

$$\tau_1 = \omega \frac{(1 - M(\frac{1}{r} + \frac{2r}{r^2}))}{(1 - \frac{2M}{R \tan(r/R)} - \bar{r}^2 \omega^2)} \quad (4.90)$$

And

$$\begin{aligned} \Delta\phi = & -2\pi((1 - M(\frac{1}{R \sin(r/R) \cos(r/R)} + \frac{2}{R \tan(r/R)})) \times \\ & (1 - \frac{2M}{R \tan(r/R)} - R^2 \sin^2(r/R) \omega^2)^{-1/2} - 1) \end{aligned} \quad (4.91)$$

As $R \rightarrow \infty$ this reduces to

$$\Delta\phi = -2\pi((1 - \frac{3M}{r})(1 - \frac{2M}{r} - r^2 \omega^2)^{-1/2} - 1) \quad (4.92)$$

Fokker-De Sitter precession.

A generalized version of the Fokker-De Sitter precession is obtained by specializing the above results to the case of a geodesic along which $\kappa = 0$ so that we recover the generalized Keplerian frequency

$$\omega^2 = \frac{M}{R^3 \sin^3(r/R) \cos(r/R)} \quad (4.93)$$

In this case

$$\tau_1^2 = \omega^2 \cos^2(r/R) \quad (4.94)$$

so that the orbital gyroscopic precession frequency is not the same as the angular speed ω . Thus even in the absence of rotation the direct effect of the background is manifest. There is a significant modification of the results from the asymptotically flat case.

In one orbital revolution, the gyroscope rotates by

$$\Delta\phi = -2\pi((\cos^4(r/R) - \frac{M}{R \tan(r/R)}(1 + \frac{2r}{R \tan(r/R)}))^{1/2} - 1) \quad (4.95)$$

This reduces to

$$\Delta\phi = -2\pi((1 - \frac{3M}{r})^{1/2} - 1) \quad (4.96)$$

as $R \rightarrow \infty$ thereby recovering the well-known Schwarzschild result.

4.5.2 Einstein universe

The general case.

Taking $M = 0$ in equations(4.84-4.85) the results are automatically specialized to the case of the Einstein universe. We note that the circular orbits are not geodesics as in the flat

case as there are no geodesics in the Einstein universe. Nevertheless, non-geodesic circular orbits may be examined in order to find analogues of the Thomas precession.

We now have

$$\kappa^2 = \frac{\bar{r}^2 \omega^4 \sin^2 \theta \sin^2(r/R)}{(1 - \bar{r}^2 \omega^2 \sin^2 \theta)^2} \quad (4.97)$$

$$\tau_1^2 = \frac{\omega^2 (1 - \sin^2(r/R) \sin^2 \theta)}{(1 - \bar{r}^2 \omega^2 \sin^2 \theta)^2} \quad (4.98)$$

$$\tau_2^2 = 0 \quad (4.99)$$

while equations(4.86) reduce to

$$\begin{aligned} e_{(0)}^a &= \frac{1}{\sqrt{1 - \bar{r}^2 \sin^2 \theta \omega^2}} (1, 0, 0, \omega) \\ e_{(1)}^a &= (0, -\sin \theta, \frac{r \cos \theta}{\bar{r}^2}, 0) \\ e_{(2)}^a &= \frac{r}{\bar{r}^2 \sin \theta \sqrt{1 - \omega^2 \bar{r}^2 \sin^2 \theta}} (\omega \bar{r}^2 \sin^2 \theta, 0, 0, -1) \\ e_{(3)}^a &= (0, \cos \theta, -\frac{r \sin \theta}{\bar{r}^2}, 0) \end{aligned} \quad (4.100)$$

We see that τ_2 vanishes identically. This implies that the precession is about the normal to the orbital plane as should be expected from the symmetry of the situation.

Thomas precession.

The above expressions reduce on the $\theta = \pi/2$ plane to

$$\kappa^2 = \frac{R^2 \sin^2(r/R) \omega^4 \cos^2(r/R)}{1 - (R^2 \sin^2(r/R) \omega^2)^2} \quad (4.101)$$

$$\tau_1^2 = \frac{\omega^2}{1 - (R^2 \sin^2(r/R) \omega^2)^2} \quad (4.102)$$

$$\tau_2^2 = 0 \quad (4.103)$$

leading to the expression for the generalized version of the Thomas precession

$$\Delta\phi = -2\pi((1 - R^2 \sin^2(r/R) \omega^2)^{-1/2} - 1) \quad (4.104)$$

As $R \rightarrow \infty$ ie, in the flat spacetime, this reduces to

$$\Delta\phi = -2\pi((1 - r^2 \omega^2)^{-1/2} - 1) \quad (4.105)$$

which is the well-known formula for the Thomas precession.

4.6 Concluding Remarks

In this chapter we have investigated some examples of physical effects characteristic to a rotating black hole in the asymptotically nonflat VEK spacetime. By studying circular geodesics we have shown that there is a significant departure of the VEK results from the usual Kerr counterparts. This is due to the matching of the Vaidya spacetime to the Einstein universe wherein there are no circular geodesics at all. In the Kerr spacetime null circular geodesics exist at only one value of the radial coordinate expressed in terms of the impact parameter. At this value of the radial coordinate, there is one co-rotating and one counter-rotating orbit. Timelike geodesics exist from this point, all the way up to infinity. In contrast, the VEK case allows two different possibilities depending on the background parameter.

In the first case the null circular geodesics are present at two different values of $R \tan(r/R)$. These values are now functions of both the impact parameter and the background parameter. There is an inner photon orbit and an outer photon orbit. Each of these have one co-rotating and one counter-rotating orbits. Timelike geodesics exist sandwiched between the inner and the outer photon orbits.

In the second case, null geodesics occur at only one value of $R \tan(r/R)$ with one co-rotating and one counter-rotating orbit. There is a complete absence of timelike circular geodesics. The impact parameter also reflects this feature as we have shown in the special case $a = 0$ of the VES spacetime.

By investigating the phenomenon of gyroscopic precession in the VEK spacetime we have shown that the background affects the precession in both modulated and direct effects. The first torsion which in the Kerr case coincided with the Schwarzschild Keplerian frequency now no longer coincides with the VES generalized Keplerian frequency. It is now a function of the angular momentum parameter as well in contrast to the Kerr case. This brings about a pronounced modification of the results of the Kerr case. In particular this gives rise to a generalized version of the Schiff precession. Moreover, even in the special cases of the generalized versions of the Fokker-De Sitter precession in the VES spacetime, the background prevents the first torsion from being equivalent to the generalized Keplerian frequency. Finally, the generalized version of the Thomas precession in the Einstein universe is also considerably modified.

Thus we may conclude that the influence of the nonflat background on the physical effects associated with black hole rotation investigated herein is significant and manifest.

**BLACK HOLES
IN
COSMOLOGICAL BACKGROUNDS**

*A thesis
submitted for the degree of
Doctor of Philosophy
in the Faculty of Science
University of Calicut, India*

B. S. Ramachandra

**Indian Institute of Astrophysics
Bangalore, India**

March 2003

Chapter 5

The Carter Constant and the Petrov Classification of the VEK Spacetime

5.1 Introduction

Having discussed the geometry of the event horizon and some physical effects in the VEK spacetime, we now turn to the investigation of certain separability properties of the geodesics and the Petrov classification of the spacetime. We study also certain quantities that have proved to be indispensable in defining particle angular momentum in a stationary, axisymmetric spacetime with a view to extend them to the VEK case. These quantities are the Killing tensor, the Killing spinor and the Killing-Yano tensor. Their significance lies in the fact that on one hand, they are the only quantities that seem to support particle angular momentum structure. On the other hand, together, these quantities relate the properties of the geodesics, in particular, the separability of the Hamilton-Jacobi equation and the Carter constant, to the Petrov classification of the spacetime.

The existence of these quantities in the VEK spacetime is not at all obvious. There are two reasons for this. One is that the separability properties of the equations of mathematical physics possessed by the Kerr metric may not be possessed by the VEK metric. In fact, going by the evidence of our studies on geodesics in the VES and the VEK spacetimes, it is not at all unlikely to expect that the drastic modification in the nature of the geodesics from their asymptotically flat counterparts would affect the separability properties also.

Another reason has to do with the Petrov classification of the spacetime. The Kerr spacetime is of Petrov type-D and is a vacuum spacetime. Therefore it admits a Killing spinor. The Killing spinor goes into defining the Killing-Yano tensor. The type-D nature of the Kerr spacetime relies on the vacuum, asymptotically flat features of the spacetime. When one or both of these features are relaxed it need not be expected that the classification remains invariant. Even if the type-D classification is retained as in the VEK case, but the spacetime is non-vacuum and asymptotically non-flat, it is not at all clear whether the

Killing spinor and hence, the Killing-Yano tensor exists.

A significant feature of the Kerr metric is that almost all the equations of mathematical physics are separable. Central among these equations is the Hamilton-Jacobi equation. The importance of this stems from the fact that the solution of the Hamilton-Jacobi equation gives complete information on the nature of the geodesics. The Kerr metric being stationary and axisymmetric there exist two Killing vector fields, one timelike and one rotational. These lead directly to two conserved quantities namely the energy and the azimuthal angular momentum. The metric itself leads to another conserved quantity namely the rest mass. In general, there is no reason to expect any other conserved quantities apart from these three. However, as discovered by Carter[28] in his investigations on the Hamilton-Jacobi equation for the Kerr metric, there exists a fourth constant of motion which has proved to be extremely useful in the study of geodesics in the Kerr spacetime. Since it is a quadratic constant of motion, it may be expressed as the contraction of a symmetric rank two tensor, called the Killing tensor, twice with a four-momentum. The Killing tensor, in turn, may be expressed as a 'square' of an antisymmetric rank two tensor, the Killing-Yano tensor as shown by Penrose and Floyd[29][30].

This discovery came from another line of investigation, viz, that related to the Petrov classification of the spacetime. It was shown by Walker and Penrose[31] that an asymptotically flat type-D vacuum spacetime admits a Killing spinor. The vacuum, type-D character of the Kerr spacetime ensures that the principal null congruences are geodesic and shear-free and that there is only one non-vanishing Weyl scalar Ψ_2 . The Killing spinor is constructed out of Ψ_2 and the basis spinors. The Killing spinor, in turn, may be used to construct the Killing-Yano tensor. The Killing tensor is now obtained as a partial contraction of Killing-Yano tensors twice as shown by Floyd[30]. Thus once again one arrives at the same Carter constant.

The above discussion indicates that the Killing-Yano tensor serves as a link between the Killing tensor and the Killing spinor. Therefore the Killing-Yano tensor itself, in turn, depends on either the separability property of the Hamilton-Jacobi equation or the type-D character of the spacetime both of which are tied up with the existence of the Carter constant. Closely related to these properties is the fact that the Kerr spacetime is vacuum and asymptotically flat. On one hand the property of being type-D depends on the vacuum nature of the spacetime. On the other hand, the property of asymptotic flatness enables the physical quantities to be appropriately identified through the Killing-Yano tensor.

To reiterate then, in the case of the non-vacuum, asymptotically non-flat VEK spacetime there are no grounds to expect that either of the above properties be valid. It is not improbable that the matter distribution surrounding the VEK black hole would be expected to affect the classification and the asymptotically non-flat feature of the spacetime may make

it difficult to define physical quantities. Nevertheless, as we shall show both the separability property and the type-D nature of the spacetime hold in the case of the VEK spacetime.

This chapter is organized as follows. In Section 5.2, we show that the Carter constant exists by constructing it following the original method of Carter[35] in the case of the Kerr metric. In Section 5.3, we present the Killing tensor. In Section 5.4, we discuss the classification of the VEK spacetime. Employing the Newman-Penrose formalism we calculate the spin coefficients and contrast the results with the Kerr case. In Section 5.5, we present calculations to demonstrate explicitly that the special case of the VEK spacetime, namely, the VES spacetime is Petrov type-D. After a brief review of the 2-spinor formalism in Section 5.6, we go on to construct the Killing spinor for the VEK spacetime. This will be followed by Section 5.7 wherein we construct the Killing-Yano tensor. Section 5.8 carries the concluding remarks.

5.2 The Carter Constant

The discovery by Carter of the fourth constant which now bears his name was one of the remarkable results on investigations involving the Kerr metric. In his studies[28] Carter was motivated by the need to integrate the geodesic equations. As discussed in Chapters 2 and 4, the geodesic equation for a free particle of mass m can be obtained from the Hamiltonian

$$\mathcal{H} = \frac{1}{2}g^{ab}p_a p_b \quad (5.1)$$

where

$$p_a = g_{ab}\dot{x}^a \quad (5.2)$$

is the four-momentum. Since the affine parameter does not appear explicitly in the Hamiltonian, the Hamiltonian itself is automatically a constant of the motion and is given by

$$\mathcal{H} = \frac{1}{2}m^2 \quad (5.3)$$

In a stationary, axisymmetric spacetime wherein there are two cyclic coordinates corresponding to the timelike and rotational Killing trajectories we have in addition to the above, two other constants. The four-momenta p_t and p_ϕ where t and ϕ are the time and azimuthal Boyer-Lindquist coordinates respectively, are also conserved.

For a complete set of first integrals of the motion we need in all four constants of the motion. Thus a fourth constant of the motion is needed. This would not exist in a general stationary, axisymmetric spacetime. However, in the case of the Kerr spacetime the fourth constant does exist as shown by Carter. Since the Kerr spacetime is vacuum and asymptotically flat there is no reason to expect that the the non-vacuum, asymptotically Einstein VEK spacetime admits a fourth constant. Nevertheless, proceeding in analogy

with Carter's construction of the fourth constant we now construct it for the VEK space-time. We first recall the method of Carter[35] which bypasses the necessity of going through the Hamilton-Jacobi equation. Thus the Carter constant may be obtained directly by inspection of the Hamiltonian by means of the following lemma due to Carter.

Lemma: Let the Hamiltonian have the form

$$\mathcal{H} = \frac{1}{2} \frac{\mathcal{H}_r + \mathcal{H}_\theta}{U_r + U_\theta} \quad (5.4)$$

where U_r and U_θ are single variable functions of the coordinates r and θ respectively and where \mathcal{H}_r is independent of the momentum p_θ and of all the coordinate functions other than r and \mathcal{H}_θ is independent of the momentum p_r and of all the coordinate functions other than θ . Then the quantity

$$\mathcal{K} = \frac{U_r \mathcal{H}_\theta - U_\theta \mathcal{H}_r}{U_r + U_\theta} \quad (5.5)$$

Poisson commutes with \mathcal{H} and hence is a constant of the motion. The proof is as follows.

Since \mathcal{H}_r commutes with \mathcal{H}_θ and U_r commutes with \mathcal{H}_θ and $U_r + U_\theta$ we obtain

$$[\mathcal{H}_r, \mathcal{H}]_{PB} = \frac{1}{2} (\mathcal{H}_r + \mathcal{H}_\theta) \left[\mathcal{H}_r, \frac{1}{U_r + U_\theta} \right]_{PB} \quad (5.6)$$

and

$$[U_r, \mathcal{H}]_{PB} = \frac{1}{2(U_r + U_\theta)} [U_r, \mathcal{H}_r]_{PB} \quad (5.7)$$

We thus obtain

$$\begin{aligned} \left[\mathcal{H}_r, \frac{1}{U_r + U_\theta} \right]_{PB} &= -\frac{1}{(U_r + U_\theta)^2} \frac{\partial \mathcal{H}_r}{\partial p_r} \frac{dU_r}{dr} \\ &= -\frac{1}{(U_r + U_\theta)^2} [U_r, \mathcal{H}_r]_{PB} \end{aligned} \quad (5.8)$$

Using this in equations(5.6) and (5.7) we obtain

$$[\mathcal{H}_r, \mathcal{H}] = 2\mathcal{H}[U_r, \mathcal{H}] \quad (5.9)$$

This may be written as

$$[2U_r \mathcal{H} - \mathcal{H}_r, \mathcal{H}] = 0 \quad (5.10)$$

or

$$[\mathcal{K}, \mathcal{H}] = 0 \quad (5.11)$$

since $\mathcal{K} = 2U_r \mathcal{H} - \mathcal{H}_r$ as can be readily verified.

It therefore follows that the quantity \mathcal{K} is a constant of the motion.

In order to apply this lemma to the VEK Hamiltonian we note that the VEK metric in generalized Boyer-Lindquist form may be written as

$$ds^2 = \left(1 - \frac{2M\bar{r}}{\bar{\rho}^2}\right) dt^2 - \frac{\bar{\rho}^2}{\bar{\Delta}} dr^2 - \frac{\bar{\rho}^2}{\zeta^2} d\theta^2 - \frac{\sin^2 \theta}{\bar{\rho}^2} \bar{\Sigma}^2 d\phi^2 + 2\left(\frac{2Mra \sin^2 \theta}{\bar{\rho}^2}\right) dt d\phi \quad (5.12)$$

where \bar{r} , \bar{r} , $\bar{\rho}$, $\bar{\Delta}$, $\bar{\Sigma}$ and ζ are as in equation(3.13) of Chapter 3.

The contravariant form of this metric is given by

$$\begin{aligned} \left(\frac{\partial}{\partial s}\right)^2 &= \frac{\bar{\Sigma}^2}{\bar{\rho}^2 \bar{\Delta}} \frac{\partial}{\partial t} \otimes \frac{\partial}{\partial t} - \frac{\bar{\Delta}}{\bar{\rho}^2} \frac{\partial}{\partial r} \otimes \frac{\partial}{\partial r} - \frac{\zeta^2}{\bar{\rho}^2} \frac{\partial}{\partial \theta} \otimes \frac{\partial}{\partial \theta} - \\ &\quad \left(\frac{1}{\sin^2 \theta} - \frac{a^2}{\bar{\Delta}}\right) \frac{\partial}{\partial \phi} \otimes \frac{\partial}{\partial \phi} + 2\frac{2Mra}{\bar{\rho}^2 \bar{\Delta}} \frac{\partial}{\partial t} \otimes \frac{\partial}{\partial \phi} \end{aligned} \quad (5.13)$$

Therefore the Hamiltonian is

$$2\mathcal{H} = \frac{\bar{\Sigma}^2}{\bar{\rho}^2 \bar{\Delta}} p_t^2 - \frac{\bar{\Delta}}{\bar{\rho}^2} p_r^2 - \frac{\zeta^2}{\bar{\rho}^2} p_\theta^2 - \left(\frac{1}{\sin^2 \theta} - \frac{a^2}{\bar{\Delta}}\right) p_\phi^2 + 2\frac{2Mra}{\bar{\rho}^2 \bar{\Delta}} p_t p_\phi \quad (5.14)$$

We now bring the Hamiltonian to a form in which the above Lemma may be applied. We rewrite the Hamiltonian as

$$2\mathcal{H} = \frac{1}{\bar{r}^2 + a^2 \cos^2 \theta} \left(\frac{(\bar{r}^2 + a^2)^2}{\bar{\Delta}} p_t^2 - \bar{\Delta} p_r^2 + \frac{a^2}{\bar{\Delta}} p_\phi^2 + 2\frac{2Mra}{\bar{\rho}^2 \bar{\Delta}} p_t p_\phi - a^2 \sin^2 \theta p_t^2 - \zeta^2 p_\theta^2 - \frac{p_\phi^2}{\sin^2 \theta} \right) \quad (5.15)$$

This is clearly of the form given in equation(5.4) with

$$\begin{aligned} \mathcal{H}_r &= \frac{(\bar{r}^2 + a^2)^2}{\bar{\Delta}} p_t^2 - \bar{\Delta} p_r^2 + \frac{a^2}{\bar{\Delta}} p_\phi^2 + 2\frac{2Mra}{\bar{\rho}^2 \bar{\Delta}} p_t p_\phi \\ \mathcal{H}_\theta &= -a^2 \sin^2 \theta p_t^2 - \zeta^2 p_\theta^2 - \frac{p_\phi^2}{\sin^2 \theta} \\ \mathcal{U}_r &= \bar{r}^2 \\ \mathcal{U}_\theta &= a^2 \cos^2 \theta \end{aligned} \quad (5.16)$$

Therefore we immediately obtain

$$\begin{aligned} \mathcal{K} &= -\frac{a^2}{\bar{\rho}^2 \bar{\Delta}} \left((\bar{r}^2 + a^2)^2 + \bar{\Delta} \bar{r}^2 \sin^2 \theta \right) p_t^2 + \frac{a^2 \cos^2 \theta \bar{\Delta}}{\bar{\rho}^2} p_r^2 - \frac{\zeta^2 \bar{r}^2}{\bar{\rho}^2} p_\theta^2 \\ &\quad - \frac{(a^2 \cos^2 \theta \sin^2 \theta + \bar{\Delta} \bar{r}^2)}{\bar{\rho}^2 \bar{\Delta} \sin^2 \theta} p_\phi^2 - \frac{(2a(\bar{r}^2 + a^2)a^2 \cos^2 \theta + \bar{r}^2 \bar{\Delta})}{\bar{\rho}^2 \bar{\Delta}} p_t p_\phi \end{aligned} \quad (5.17)$$

which is the Carter constant for the VEK metric.

That \mathcal{K} is a constant of the motion follows by the fact that the Poisson bracket of \mathcal{K} and \mathcal{H} vanishes.

Thus we have shown that the Carter constant exists despite the fact that the VEK space-time is non-vacuum and asymptotically non-flat.

In the phase space view the Carter constant is a quadratic constant of motion. In analogy with the metric which also leads to a quadratic constant of motion, namely, the rest mass squared, this motivates the possibility of expressing the Carter constant in terms of a similar quantity. Since the metric is expressed by means of a symmetric second rank tensor we may express the Carter constant by means of a similar symmetric second rank tensor called the Killing tensor which we shall now discuss.

5.3 The Killing Tensor

The Killing tensor is an extension of the concept of a Killing vector field to a tensor field with analogous properties.

We recall that a vector field ξ_a is termed a Killing vector field if the Lie derivative of the metric along ξ_a vanishes

$$L_\xi g_{ab} = 0 \quad (5.18)$$

This is equivalent to the Killing equations

$$\xi_{a;b} + \xi_{b;a} = 0 = \xi_{(a;b)} \quad (5.19)$$

Then, if p^a is a geodesic vector satisfying the relations $p^b p_{a;b} = 0$ the product $\xi_a p^a$ is a conserved quantity for

$$p^b (\xi_a p^a)_{;b} = p^b p^a_{;b} \xi_a + p^b p^a \xi_{a;b} = 0 \quad (5.20)$$

the first term vanishes since p^a is a geodesic and the second term vanishes due to the Killing equations. We now give the definition of a Killing tensor.

A Killing tensor $K_{ab\dots cd}$ is a symmetric tensor satisfying, in analogy with the Killing equations(5.19)

$$K_{(ab\dots cd;e)} = 0 \quad (5.21)$$

It straight away follows that $K_{ab\dots cd}$ leads to a conserved quantity. Indeed, considering the quantity $Q = K_{ab\dots cd} p^a p^b \dots p^c p^d$ we have

$$\begin{aligned} p^e (K_{ab\dots cd} p^a p^b \dots p^c p^d)_{;e} &= 2p^c p^a_{;e} p^b \dots p^c p^d K_{ab\dots cd} + \\ & 2p^e p^a p^b_{;e} \dots p^c p^d K_{ab\dots cd} + \dots + p^e p^a p^b K_{ab\dots cd;e} \\ &= 0 \end{aligned} \quad (5.22)$$

the terms other than the last vanish since p^a is geodesic and the last term vanishes by the Killing tensor equations(5.21).

For a Killing tensor of rank two which is what we shall be dealing with the above definition reduces to the simple form

$$p^e(K_{ab}p^ap^b) = 2p^ep^a{}_{;e}p^bK_{ab} + p^ep^ap^bK_{ab;e} = 0 \quad (5.23)$$

Just as a Killing vector field is associated with a linear constant of motion $\xi_a p^a$, $K_{ab}p^ap^b$ is associated with a quadratic constant of motion.

The metric tensor trivially satisfies the requirements for being a Killing tensor, the corresponding conserved quantity being the particle rest-mass.

The phase space view of the Killing tensor reveals the following. Just as the metric tensor multiplied twice by a four-momentum is twice the Hamiltonian, the Killing tensor multiplied twice by a four-momentum is associated with the Carter constant which, being a constant of the motion, Poisson-commutes with the Hamiltonian.

We now exhibit the Killing tensor for the VEK spacetime. First we note that the Carter constant introduced in equation(5.17) may be expressed through the contravariant form

$$\begin{aligned} K &= K^{ab} \frac{\partial}{\partial x^a} \otimes \frac{\partial}{\partial x^b} \\ &= -\frac{a^2}{\bar{\rho}^2 \bar{\Delta}} \left((\bar{r}^2 + a^2)^2 + \bar{\Delta} \bar{r}^2 \sin^2 \theta \right) \frac{\partial}{\partial t} \otimes \frac{\partial}{\partial t} + \frac{a^2 \cos^2 \theta \bar{\Delta}}{\bar{\rho}^2} \frac{\partial}{\partial r} \otimes \frac{\partial}{\partial r} \\ &\quad - \frac{\zeta^2 \bar{r}^2}{\bar{\rho}^2} \frac{\partial}{\partial \theta} \otimes \frac{\partial}{\partial \theta} - \frac{(a^2 \cos^2 \theta \sin^2 \theta + \bar{\Delta} \bar{r}^2)}{\bar{\rho}^2 \bar{\Delta} \sin^2 \theta} \frac{\partial}{\partial \phi} \otimes \frac{\partial}{\partial \phi} \\ &\quad - \frac{(2a(\bar{r}^2 + a^2)a^2 \cos^2 \theta + \bar{r}^2 \bar{\Delta})}{\bar{\rho}^2 \bar{\Delta}} \frac{\partial}{\partial t} \otimes \frac{\partial}{\partial \phi} \end{aligned} \quad (5.24)$$

We identify this as the Killing tensor for the VEK spacetime

$$K^{ab} = \begin{pmatrix} -\frac{a^2}{\bar{\rho}^2 \bar{\Delta}} \left((\bar{r}^2 + a^2)^2 + \bar{\Delta} \bar{r}^2 \sin^2 \theta \right) & 0 & 0 & -\frac{(2a(\bar{r}^2 + a^2)a^2 \cos^2 \theta + \bar{r}^2 \bar{\Delta})}{\bar{\rho}^2 \bar{\Delta}} \\ 0 & \frac{a^2 \cos^2 \theta \bar{\Delta}}{\bar{\rho}^2} & 0 & 0 \\ 0 & 0 & -\frac{\zeta^2 \bar{r}^2}{\bar{\rho}^2} & 0 \\ -\frac{(2a(\bar{r}^2 + a^2)a^2 \cos^2 \theta + \bar{r}^2 \bar{\Delta})}{\bar{\rho}^2 \bar{\Delta}} & 0 & 0 & -\frac{(a^2 \cos^2 \theta \sin^2 \theta + \bar{\Delta} \bar{r}^2)}{\bar{\rho}^2 \bar{\Delta} \sin^2 \theta} \end{pmatrix} \quad (5.25)$$

The covariant form of the Killing tensor is

$K_{ab} =$

$$\begin{pmatrix} \frac{(-a^2 \cos^2 \theta \bar{\Delta} + \bar{r}^2 \sin^2 \theta)}{\bar{\rho}^2} & 0 & 0 & \frac{2a \sin^2 \theta}{\bar{\rho}^2} (\bar{\Delta} a^2 \cos^2 \theta + \bar{r}^2 (\bar{r}^2 + a^2)) \\ 0 & \frac{a^2 \cos^2 \theta \bar{\rho}^2}{\bar{\Delta}} & 0 & 0 \\ 0 & 0 & \frac{\bar{r}^2 \bar{\rho}^2}{\zeta^2} & 0 \\ \frac{2a \sin^2 \theta}{\bar{\rho}^2} (\bar{\Delta} a^2 \cos^2 \theta + \bar{r}^2 (\bar{r}^2 + a^2)) & 0 & 0 & -\frac{\sin^2 \theta}{\bar{\rho}^2} (a^4 \cos^2 \theta \sin^2 \theta \bar{\Delta} + \bar{r}^2 (\bar{r}^2 + a^2)^2) \end{pmatrix} \quad (5.26)$$

$$\begin{aligned} K &= K_{ab} dx^a \otimes dx^b \\ &= \frac{(-a^2 \cos^2 \theta \bar{\Delta} + \bar{r}^2 \sin^2 \theta)}{\bar{\rho}^2} dt^2 + \frac{a^2 \cos^2 \theta \bar{\rho}^2}{\bar{\Delta}} dr^2 - \frac{\bar{r}^2 \bar{\rho}^2}{\zeta^2} d\theta^2 \\ &\quad - \frac{\sin^2 \theta}{\bar{\rho}^2} (a^4 \cos^2 \theta \sin^2 \theta \bar{\Delta} + \bar{r}^2 (\bar{r}^2 + a^2)^2) d\phi^2 \\ &\quad + \frac{2a \sin^2 \theta}{\bar{\rho}^2} (\bar{\Delta} a^2 \cos^2 \theta + \bar{r}^2 (\bar{r}^2 + a^2)) dt d\phi \end{aligned} \quad (5.27)$$

In order to see the significance of the Killing tensor it is instructive to look at the limiting case of the Schwarzschild space-time by taking $R \rightarrow \infty$ and $a = 0$. We then have

$$K = -r^4 d\theta^2 - r^4 \sin^2 \theta d\phi^2 \quad (5.28)$$

The Schwarzschild metric admits three Killing vectors \hat{L}_x , \hat{L}_y , and \hat{L}_z arising from spherical symmetry

$$\begin{aligned} \hat{L}_x &= -\sin \phi \frac{\partial}{\partial \theta} - \cot \theta \cos \phi \frac{\partial}{\partial \phi} \\ \hat{L}_y &= \cos \phi \frac{\partial}{\partial \theta} - \cot \theta \sin \phi \frac{\partial}{\partial \phi} \\ \hat{L}_z &= \frac{\partial}{\partial \phi} \end{aligned} \quad (5.29)$$

The Lie brackets of these vector fields are

$$\begin{aligned} [\hat{L}_x, \hat{L}_y] &= -\hat{L}_z \\ [\hat{L}_y, \hat{L}_z] &= -\hat{L}_x \\ [\hat{L}_z, \hat{L}_x] &= -\hat{L}_y \end{aligned} \quad (5.30)$$

With these K^{ab} may be expressed as

$$K^{ab} = \hat{L}_x^a \hat{L}_x^b + \hat{L}_y^a \hat{L}_y^b + \hat{L}_z^a \hat{L}_z^b \quad (5.31)$$

The three Killing vectors \hat{L}_x , \hat{L}_y , \hat{L}_z give us natural definitions of components of angular momentum

$$\begin{aligned} L_x &= \hat{L}_x^a p_a, \\ L_y &= \hat{L}_y^a p_a, \\ L_z &= \hat{L}_z^a p_a, \end{aligned} \quad (5.32)$$

and the Carter constant is found to be the square of the angular momentum vector

$$\mathcal{K} = K^{ab}p_a p_b = (\hat{L}_x^a \hat{L}_x^b + \hat{L}_y^a \hat{L}_y^b + \hat{L}_z^a \hat{L}_z^b)p_a p_b = L_x^2 + L_y^2 + L_z^2 \quad (5.33)$$

In this limiting case of the Schwarzschild spacetime however, the Killing tensor from which it arose, is degenerate or reducible. That is, the Killing tensor is expressible in terms of the Killing vectors.

The above discussion suggests that the Carter constant is somehow analogous to the square of the angular momentum of the particle.

In passing we may note that instead of the limiting case $R \rightarrow \infty$, $a = 0$ we may consider the special case of the VES spacetime by keeping the background parameter R finite while taking $a = 0$. An analogous discussion as in the Schwarzschild case may be given. Thus the VES spacetime also has a similar Carter constant as the Schwarzschild spacetime via a reducible Killing tensor. This is because the VES spacetime also admits the rotation group due to spherical symmetry.

The existence of the Carter constant gives strong motivation to expect that the VEK spacetime is of Petrov type-D. We now turn to a brief discussion of the Newman-Penrose formalism in order to calculate the spin coefficients for the VEK spacetime.

5.4 The Spin Coefficients and Petrov Classification

The Newman-Penrose(NP) formalism enables one to capture the full content of the Einstein field equations in terms of the five complex independent tetrad components of the Weyl scalar, the six complex independent tetrad components of the trace-free part of the Ricci tensor, the Ricci scalar, and the twelve complex spin coefficients. The Newman-Penrose equations are expressed in terms of a null tetrad (l, n, m, \bar{m}) . l and n are real while m and \bar{m} are complex conjugates of each other. The special adaptability of the Newman-Penrose formalism to the asymptotically flat, vacuum, black hole spacetimes is related to the type-D character and the Goldberg-Sachs theorem. This theorem allows one to make statements on the Petrov classification of the black hole spacetime as a consequence of the vanishing of certain spin coefficients. This, in turn, is related to the geodesic and shear-free nature of the congruences formed by the principal null-directions. Thus an examination of the spin coefficients allows one to draw conclusions on the nature of the Weyl scalars and *vice versa*. Since the asymptotically flat, vacuum black hole spacetimes are all of Petrov type-D, it is convenient to examine such spacetimes by means of a null tetrad in which the spin coefficients $\kappa, \sigma, \lambda, \nu$ and all the Weyl scalars except Ψ_2 vanish.

In a non-vacuum, asymptotically non-flat VEK spacetime however, it is not possible to draw conclusions on the Petrov classification by an examination of the spin coefficients

alone. To do so would need at least a generalized version of the Goldberg-Sachs theorem applicable to non-vacuum asymptotically non-flat spacetimes. Nevertheless, the existence of the Carter constant and its strong relation to the Petrov classification in the case of vacuum asymptotically flat black hole spacetimes motivates us to discuss the spin coefficients and their relation to the Weyl scalars in the VEK spacetime. We now present the null tetrad formalism for the VEK spacetime.

5.4.1 The Newman-Penrose formalism

The NP null tetrad may be obtained by a consideration of the shear-free null congruences that emerge while solving the equations for the null geodesics. We may recall that in Chapter 4, we obtained the null geodesics that are members of the principal null congruences confined to the equatorial plane. This procedure may be continued to construct the null tetrad. However, in what follows we shall construct the null tetrad directly from the metric.

We write the VEK metric in generalized Boyer-Lindquist coordinates in the form

$$ds^2 = \frac{\bar{\Delta}}{\bar{\rho}^2}(dt - a \sin^2 \theta d\phi)^2 - \frac{\sin^2 \theta}{\bar{\rho}^2}((\bar{r}^2 + a^2)d\phi - a dt)^2 - \frac{\bar{\rho}^2}{\bar{\Delta}}dr^2 - \frac{\bar{\rho}^2}{\zeta^2}d\theta^2 \quad (5.34)$$

Introducing the tetrad forms $e^A = e_a^A dx^a$ where the tetrad indices A, B, C, \dots range from $A = 0, 1, 2, 3$, and expressing the metric as

$$ds^2 = \eta_{AB} e^A \otimes e^B \quad (5.35)$$

we may pick out the tetrad forms

$$\begin{aligned} e^0 &= \frac{\bar{\Delta}}{\bar{\rho}}(dt - a \sin^2 \theta d\phi) \\ e^1 &= \frac{\bar{\rho}}{\bar{\Delta}}dr \\ e^2 &= \frac{\bar{\rho}}{\zeta}d\theta \\ e^3 &= \frac{\sin \theta}{\bar{\rho}}((\bar{r}^2 + a^2)d\phi - a dt) \end{aligned} \quad (5.36)$$

From these we may define new tetrad forms $E^A = E_a^A dx^a$ by

$$\begin{aligned} E^0 &= \frac{\sqrt{2\bar{\rho}}}{\sqrt{\bar{\Delta}}}e^0 = \sqrt{2}(dt - a \sin^2 \theta d\phi) \\ E^1 &= \frac{\sqrt{\bar{\Delta}}}{\sqrt{2\bar{\rho}}}e^1 = \frac{\bar{\rho}^2}{\sqrt{2\bar{\Delta}}} \\ E^2 &= \frac{\sqrt{2}}{\bar{\rho}_1}e^2 = \frac{\sqrt{2\bar{\rho}^2}}{\zeta}d\theta \\ E^3 &= \frac{\sqrt{2}}{\bar{\rho}_1}e^3 = \frac{\sqrt{2} \sin \theta}{\bar{\rho}_1}((\bar{r}^2 + a^2)d\phi - a dt) \end{aligned} \quad (5.37)$$

These tetrad forms may be most conveniently used to arrive at the null tetrad.

5.4.2 The Newman-Penrose null tetrad

The null tetrad forms may be obtained immediately from the above tetrad forms E^A as

$$\begin{aligned}
 l &= \frac{\bar{\rho}}{\sqrt{\Delta}}(E^0 - E^1) \\
 n &= \frac{\sqrt{\Delta}}{2\bar{\rho}}(E^0 + E^1) \\
 m &= -\frac{1}{\sqrt{2\bar{\rho}_1}}(E^2 + iE^3) \\
 \bar{m} &= -\frac{1}{\sqrt{2\bar{\rho}_1^*}}(E^2 - iE^3)
 \end{aligned} \tag{5.38}$$

where we have defined

$$\begin{aligned}
 \bar{\rho}_1 &= \bar{r} + ia \cos \theta \\
 \bar{\rho}_1^* &= \bar{r} - ia \cos \theta
 \end{aligned} \tag{5.39}$$

and made use of the identity $\bar{\rho}^2 = \bar{\rho}_1 \bar{\rho}_1^*$

Explicitly we have

$$\begin{aligned}
 l &= l_a dx^a = dt - \frac{\bar{\rho}^2}{\Delta} dr - a \sin^2 \theta d\phi \\
 n &= n_a dx^a = \frac{\bar{\Delta}}{2\rho^2} dt + \frac{1}{2} dr - \frac{a^2 \sin^2 \theta \bar{\Delta}}{2\rho^2} d\phi \\
 m &= m_a dx^a = \frac{1}{\sqrt{2\bar{\rho}_1}} (ia \sin \theta dt - \frac{\bar{\rho}^2}{\zeta} d\theta - i(r^2 + a^2) \sin \theta d\phi) \\
 \bar{m} &= \bar{m}_a dx^a = \frac{1}{\sqrt{2\bar{\rho}_1^*}} (-ia \sin \theta dt - \frac{\bar{\rho}^2}{\zeta} d\theta + i(r^2 + a^2) \sin \theta d\phi)
 \end{aligned} \tag{5.40}$$

The contravariant form of the above tetrad is

$$\begin{aligned}
 \tilde{l} &= \frac{\bar{r}^2 + a^2}{\Delta} \frac{\partial}{\partial t} + \frac{\partial}{\partial r} + \frac{a}{\Delta} \frac{\partial}{\partial \phi} \\
 \tilde{n} &= \frac{\bar{r}^2 + a^2}{2\bar{\rho}^2} \frac{\partial}{\partial t} - \frac{1}{2} \frac{\bar{\Delta}}{\bar{\rho}^2} \frac{\partial}{\partial r} + \frac{a}{2\bar{\rho}^2} \frac{\partial}{\partial \phi} \\
 \tilde{m} &= \frac{ia \sin \theta}{\sqrt{2\bar{\rho}_1}} \frac{\partial}{\partial t} + \frac{1}{\sqrt{2\bar{\rho}_1}} \frac{\partial}{\partial \theta} + \frac{i \csc \theta}{\sqrt{2\bar{\rho}_1}} \frac{\partial}{\partial \phi} \\
 \tilde{\bar{m}} &= -\frac{ia \sin \theta}{\sqrt{2\bar{\rho}_1^*}} \frac{\partial}{\partial t} + \frac{1}{\sqrt{2\bar{\rho}_1^*}} \frac{\partial}{\partial \theta} - \frac{i \csc \theta}{\sqrt{2\bar{\rho}_1^*}} \frac{\partial}{\partial \phi}
 \end{aligned} \tag{5.41}$$

It is easily verified that l, n, m, \bar{m} satisfy the standard normalization relations

$$\begin{aligned}
 l \cdot l &= n \cdot n = m \cdot \bar{m} = \bar{m} \cdot \bar{m} = 0 \\
 l \cdot n &= 1 \\
 m \cdot \bar{m} &= -1
 \end{aligned} \tag{5.42}$$

where the dot denotes the operation of the inner product or contraction.

In order to facilitate the calculations we note the following useful relations

$$\begin{aligned}
l \wedge l &= n \wedge n = m \wedge m = \bar{m} \wedge \bar{m} = 0 \\
l \wedge n &= (dt - a \sin^2 \theta d\phi) \wedge dr \\
m \wedge \bar{m} &= -\frac{i \sin \theta}{\zeta} (adt \wedge d\theta + (\bar{r}^2 + a^2) d\theta \wedge d\phi)
\end{aligned} \tag{5.43}$$

The coordinate forms dt , dr , $d\theta$ and $d\phi$ may be expressed in terms of the null forms as

$$\begin{aligned}
dt &= \frac{\bar{r}^2 + a^2}{2\bar{\rho}^2} l + \frac{\bar{r}^2 + a^2}{\bar{\Delta}} n + \frac{ia \sin \theta}{\sqrt{2}\bar{\rho}^2} (\bar{\rho}_1 m - \bar{\rho}_1^* \bar{m}) \\
dr &= -\frac{1}{2} \frac{\bar{\Delta}}{\bar{\rho}^2} l + n \\
d\theta &= -\frac{\zeta}{\sqrt{2}\bar{\rho}^2} (\bar{\rho}_1 m + \bar{\rho}_1^* \bar{m}) \\
d\phi &= \frac{a}{2\bar{\rho}^2} l + \frac{a}{\bar{\Delta}} n + \frac{i}{\sqrt{2}\bar{\rho}^2 \sin \theta} (\bar{\rho}_1 m - \bar{\rho}_1^* \bar{m})
\end{aligned} \tag{5.44}$$

These satisfy

$$\begin{aligned}
dr \wedge dt &= \frac{\bar{r}^2 + a^2}{\bar{\rho}^2} l \wedge n - \frac{ia \sin \theta \bar{\Delta}}{2\sqrt{2}\bar{\rho}^4} l \wedge (\bar{\rho}_1 m - \bar{\rho}_1^* \bar{m}) + \frac{ia \sin \theta}{\sqrt{2}\bar{\rho}^2} n \wedge (\bar{\rho}_1 m - \bar{\rho}_1^* \bar{m}) \\
dr \wedge d\theta &= \frac{\bar{\Delta} \zeta}{2\sqrt{2}\bar{\rho}^4} l \wedge (\bar{\rho}_1 m + \bar{\rho}_1^* \bar{m}) - \frac{\zeta}{\sqrt{2}\bar{\rho}^2} n \wedge (\bar{\rho}_1 m + \bar{\rho}_1^* \bar{m}) \\
dr \wedge d\phi &= -\frac{a}{\bar{\rho}^2} l \wedge n - \frac{i\bar{\Delta}}{2\sqrt{2}\bar{\rho}^4 \sin \theta} l \wedge (\bar{\rho}_1 m - \bar{\rho}_1^* \bar{m}) + \frac{i}{\sqrt{2}\bar{\rho}^2 \sin \theta} n \wedge (\bar{\rho}_1 m - \bar{\rho}_1^* \bar{m}) \\
d\theta \wedge dt &= \frac{\zeta \bar{r}^2 + a^2}{2\sqrt{2}\bar{\rho}^4} l \wedge (\bar{\rho}_1 m + \bar{\rho}_1^* \bar{m}) + \frac{\zeta \bar{r}^2 + a^2}{\sqrt{2}\bar{\Delta} \bar{\rho}^2} n \wedge (\bar{\rho}_1 m + \bar{\rho}_1^* \bar{m}) + \frac{ia \sin \theta \zeta}{\bar{\rho}^2} m \wedge \bar{m} \\
d\theta \wedge d\phi &= \frac{a\zeta}{2\sqrt{2}\bar{\rho}^4} l \wedge (\bar{\rho}_1 m + \bar{\rho}_1^* \bar{m}) + \frac{a\zeta}{\sqrt{2}\bar{\rho}^2 \bar{\Delta}} n \wedge (\bar{\rho}_1 m + \bar{\rho}_1^* \bar{m}) + \frac{i\zeta}{\bar{\rho}^2 \sin \theta} m \wedge \bar{m}
\end{aligned} \tag{5.45}$$

With these preliminaries we may proceed to calculate the spin coefficients for the VEK spacetime.

5.4.3 The spin coefficients

The standard method of introducing the spin coefficients is by identifying them with the Ricci rotation coefficients[36][17][37][38][39](see also[40]) or by employing the 2-spinor formalism[41]. However, for the sake of compactness and computational simplicity we make use of the Cartan formalism as described in Penrose and Rindler[42]. This formalism requires us to calculate only the exterior derivatives of the null forms l , n and m . The

spin coefficients then appear in algebraic combinations as coefficients of the components of these exterior differentials. We first recall the expressions for dl , dn , dm as given in [42]. Our expressions differ from Penrose and Rindler in that we have replaced the primed spin coefficients by their un-primed equivalents $\tau' = -\pi$, $\sigma' = -\lambda$, $\tilde{\rho}' = -\mu$ and $\kappa' = -\nu$. We have also written out the expression for $d\bar{m}$. The bars on the spin coefficients denote complex conjugation.

$$\begin{aligned}
dl &= -\left((- \alpha - \bar{\beta} + \bar{\tau})l \wedge m + (-\beta + \tau - \bar{\alpha})l \wedge \bar{m} + (\epsilon + \bar{\epsilon})l \wedge n\right) \\
&\quad - \left(+(\bar{\rho} - \tilde{\rho})m \wedge \bar{m} - \bar{\kappa}m \wedge n - \kappa\bar{m} \wedge n\right) \\
dn &= -\left((- \nu)l \wedge m + (-\bar{\nu})l \wedge \bar{m} + (\gamma + \bar{\gamma})l \wedge n + (-\mu + \bar{\mu})m \wedge \bar{m} + (-\alpha + \pi - \beta)m \wedge n\right) \\
&\quad - \left((- \bar{\alpha} + \bar{\pi} - \beta)\bar{m} \wedge n\right) \\
dm &= \left((\gamma - \bar{\gamma} + \bar{\mu})l \wedge m + \bar{\lambda}l \wedge \bar{\mu} + (-\bar{\pi} - \tau)l \wedge n + (\beta - \bar{\alpha})m \wedge \bar{m}\right) \\
&\quad + \left(+\tilde{\rho} - \epsilon + \bar{\epsilon}\right)m \wedge n + \sigma\bar{m} \wedge n \\
d\bar{m} &= \left((\bar{\gamma} - \gamma + \mu)l \wedge \bar{m} + \lambda l \wedge m + (-\pi - \bar{\tau})l \wedge n + (\bar{\beta} - \alpha)\bar{m} \wedge m\right) \\
&\quad + \left(\bar{\rho} - \bar{\epsilon} + \epsilon\right)m \wedge n + \bar{\sigma}m \wedge n
\end{aligned} \tag{5.46}$$

We now proceed to calculate the exterior derivatives of l, n . The rest may be obtained simply once these are given as we shall show below.

We find that

$$\begin{aligned}
dl &= l_1 dr \wedge d\theta + l_2 d\theta \wedge d\phi \\
dm &= m_1 dr \wedge dt + m_2 d\theta \wedge dt + m_3 dr \wedge d\theta + m_4 dr \wedge d\phi + m_5 d\theta \wedge d\phi
\end{aligned} \tag{5.47}$$

where

$$\begin{aligned}
l_1 &= -\frac{2a^2 \sin \theta \cos \theta}{\Delta} \\
l_2 &= -2a \sin \theta \cos \theta \\
m_1 &= -\frac{i\bar{r}a \sin \theta}{\sqrt{2}\bar{\rho}_1^2 R \tan(r/R)} \\
m_2 &= -\frac{a(a - i\bar{r} \cos \theta)}{\sqrt{2}\bar{\rho}_1^2} \\
m_3 &= -\frac{\bar{r}}{\sqrt{2}\zeta R \tan(r/R)} \\
m_4 &= -\frac{i\bar{r} \sin \theta (\bar{r}^2 - a^2 + 2ia\bar{r} \cos \theta)}{\sqrt{2}\bar{\rho}_1^2 R \tan(r/R)} \\
m_5 &= -\frac{i(\bar{r}^2 + a^2)(\bar{r} \cos \theta + ia)}{\sqrt{2}\bar{\rho}_1^2}
\end{aligned} \tag{5.48}$$

It is now necessary to express dl and dm in terms of the wedge products of l, n, m, \bar{m} .

With the help of the expressions for the coordinate forms in equation(5.44) we find that

$$\begin{aligned} dl &= l_{lm}l\wedge m + l_{l\bar{m}}l\wedge\bar{m} + l_{m\bar{m}}m\wedge\bar{m} \\ dm &= m_{ln}l\wedge n + m_{lm}l\wedge m + m_{l\bar{m}}l\wedge\bar{m} + m_{nm}n\wedge m + m_{n\bar{m}}n\wedge\bar{m} + m_{m\bar{m}}m\wedge\bar{m} \end{aligned} \quad (5.49)$$

where

$$\begin{aligned} l_{lm} &= -\frac{\sqrt{2}\alpha^2\zeta\bar{\rho}_1\sin\theta\cos\theta}{\bar{\rho}^4} \\ l_{l\bar{m}} &= l_{lm}^* = -\frac{\sqrt{2}\alpha^2\zeta\bar{\rho}_1^*\sin\theta\cos\theta}{\bar{\rho}^4} \\ l_{m\bar{m}} &= -\frac{ia\zeta\bar{\Delta}\cos\theta}{\bar{\rho}^4} \\ m_{ln} &= \frac{i\sqrt{2}a\bar{\rho}^2\sin\theta}{\bar{\rho}^2\bar{\rho}_1R\tan(r/R)} \\ m_{lm} &= -\frac{\bar{\Delta}\bar{\rho}_1\bar{r}}{2\bar{\rho}^4R\tan(r/R)} \\ m_{l\bar{m}} &= 0 \\ m_{nm} &= \frac{\bar{\rho}_1\bar{r}}{\bar{\rho}^2R\tan(r/R)} \\ m_{n\bar{m}} &= \frac{(\bar{r}\cos\theta + ia)\zeta}{\sqrt{2}\bar{\rho}_1^2\sin\theta} \end{aligned} \quad (5.50)$$

We are now left with dn and $d\bar{m}$. At this stage dn may be obtained simply by noticing that

$$n = \frac{1}{2}\frac{\bar{\Delta}}{\bar{\rho}^2}l + dr \quad (5.51)$$

so that

$$dn = d\left(\frac{1}{2}\frac{\bar{\Delta}}{\bar{\rho}^2}l\right) = d\left(\frac{1}{2}\frac{\bar{\Delta}}{\bar{\rho}^2}\right)\wedge dl + \frac{1}{2}\frac{\partial}{\partial r}\left(\frac{\bar{\Delta}}{\bar{\rho}^2}\right)dr\wedge l + \frac{1}{2}\frac{\partial}{\partial\theta}\left(\frac{\bar{\Delta}}{\bar{\rho}^2}\right)d\theta\wedge l \quad (5.52)$$

From the relations(5.47), evaluating the derivatives with respect to r and θ and using equations(5.44) we get

$$dn = n_{ln}l\wedge n + n_{m\bar{m}}m\wedge\bar{m} \quad (5.53)$$

where

$$\begin{aligned} n_{ln} &= \frac{2\bar{\Delta}\bar{r}^2}{\bar{\rho}^4R\tan(r/R)} - \frac{1}{\bar{\rho}^2}\left(\frac{\bar{r}^2}{R\tan(r/R)} - m(1 - 2\sin^2(r/R))\right) \\ n_{m\bar{m}} &= -\frac{ia\bar{\Delta}\zeta\cos\theta}{\bar{\rho}^4} \end{aligned} \quad (5.54)$$

As to the expression for $d\bar{m}$ it suffices to obtain it by complex conjugating dm .

We now equate the algebraic combinations of the spin coefficients in (5.46) to the corresponding coefficients in equations(5.49) and (5.53) and solve the equations to obtain

$$\begin{aligned}
\kappa &= \nu = \sigma = \lambda = 0 \\
\epsilon &= \frac{ia \cos \theta}{2\bar{\rho}^2 R \tan(r/R)} (\bar{r} - \zeta R \tan(r/R)) \\
\bar{\rho} &= -\frac{\bar{r}}{\bar{\rho}^2 R \tan(r/R)} \left(\bar{r} + \left(\frac{\zeta R \tan(r/R)}{\bar{r}} \right) ia \cos \theta \right) \\
\mu &= -\frac{\bar{\Delta} \bar{r}}{2\bar{\rho}^4 R \tan(r/R)} \left(\bar{r} + \left(\frac{\zeta R \tan(r/R)}{\bar{r}} \right) ia \cos \theta \right) \\
\tau &= -\frac{ia \bar{r} \sin \theta}{\sqrt{2\bar{\rho}^2 \bar{\rho}_1} R \tan(r/R)} \left(\bar{r} + \left(\frac{\zeta R \tan(r/R)}{\bar{r}} \right) ia \cos \theta \right) \\
\pi &= \frac{ia \bar{r} \sin \theta}{\sqrt{2\bar{\rho}^2 \bar{\rho}_1^*} R \tan(r/R)} \left(\bar{r} + \left(\frac{\zeta R \tan(r/R)}{\bar{r}} \right) ia \cos \theta \right) \\
\beta &= \frac{(\bar{r} \cos \theta + ia)\zeta}{2\sqrt{2}\bar{\rho}_1^2 \sin \theta} - \frac{ia \bar{r} \sin \theta}{\sqrt{2\bar{\rho}^2 \bar{\rho}_1} R \tan(r/R)} \left(\bar{r} - \left(\frac{\zeta R \tan(r/R)}{\bar{r}} \right) ia \cos \theta \right) \\
\gamma &= -\frac{ia \bar{\Delta} \cos \theta}{4\bar{\rho}^4 R \tan(r/R)} (\bar{r} + \zeta R \tan(r/R)) - \frac{\bar{\Delta} \bar{r}^2}{2\bar{\rho}^4 R \tan(r/R)} \\
&\quad \frac{1}{2\bar{\rho}^2} \left(\frac{\bar{r}^2}{R \tan(r/R)} - M(1 - 2 \sin^2(r/R)) \right) \\
\alpha &= \pi - \bar{\beta}
\end{aligned} \tag{5.55}$$

We now substitute these spin coefficients into the eighteen standard Newman-Penrose equations given, for instance, in[36][17][37][38][42][39][40] to obtain the following equations

$$D\bar{\rho} = \bar{\rho}^2 + \Phi_{00} \tag{5.56}$$

$$0 = \Psi_0 \tag{5.57}$$

$$D\tau = \bar{\rho}(\tau + \bar{\pi}) + \tau(\epsilon - \bar{\epsilon}) + \Psi_1 + \Phi_{01} \tag{5.58}$$

$$D\alpha - \delta^* \epsilon = \alpha(\bar{\rho} + \bar{\epsilon} - 2\epsilon) - \bar{\beta}\epsilon + \pi(\epsilon + \bar{\rho}) + \Phi_{10} \tag{5.59}$$

$$D\beta - \delta\epsilon = \beta(\bar{\rho} - \bar{\epsilon}) - \epsilon(\bar{\alpha} - \bar{\pi}) + \Psi_1 \tag{5.60}$$

$$D\gamma - \underline{D}\epsilon = \alpha(\tau + \bar{\pi}) + \beta(\bar{\tau} + p\bar{i}) - \epsilon(\gamma + \bar{\gamma}) + \tau\pi + \Psi_2 + \Phi_{11} - \Lambda \tag{5.61}$$

$$-\delta^* \pi = \pi(\pi + \alpha - \bar{\beta}) + \Phi_{20} \tag{5.62}$$

$$D\mu - \delta\pi = \bar{\rho}\mu + \pi(\bar{\pi} - \bar{\alpha} + \beta) + \Psi_2 + 2\Lambda \tag{5.63}$$

$$-\underline{D}\pi = \mu(\pi + \bar{\tau}) + \pi(\gamma - \bar{\gamma}) + \Psi_3 + \Phi_{21} \tag{5.64}$$

$$0 = -\Psi_4 \tag{5.65}$$

$$\delta\bar{\rho} = \bar{\rho}(\bar{\alpha} + \beta) + \tau(\bar{\rho} - \bar{\rho}) - \Psi_1 + \Phi_{01} \tag{5.66}$$

$$\delta\alpha - \delta^* \beta = \mu\bar{\rho} + \alpha\bar{\alpha} + \beta\bar{\beta} - 2\alpha\beta + \gamma(\bar{\rho} - \bar{\rho}) + \epsilon(\mu - \bar{\mu}) - \Psi_2 + \Phi_{11} + \Lambda \tag{5.67}$$

$$-\delta^* \mu = \pi(\mu - \bar{\mu}) + \mu(\alpha + \bar{\beta}) - \Psi_3 + \Phi_{21} \tag{5.68}$$

$$-\underline{D}\mu = \mu^2 + \mu(\gamma + \bar{\gamma}) + \Phi_{22} \tag{5.69}$$

$$\delta\gamma - \underline{D}\beta = \gamma(\tau - \alpha - \beta) + \mu\tau - \beta(\gamma - \bar{\gamma} - \mu) + \Phi_{12} \tag{5.70}$$

$$\delta\tau = \tau(\tau + \beta - \bar{\alpha}) + \Phi_{02} \quad (5.71)$$

$$\underline{D}\bar{\rho} - \delta^*\tau = -\bar{\rho}\bar{\mu} + \tau(\bar{\beta} - \alpha - \bar{\tau}) + \bar{\rho}(\gamma + \bar{\gamma}) - \Psi_2 - 2\Lambda \quad (5.72)$$

$$\underline{D}\alpha - \delta^*\gamma = \alpha(\bar{\gamma} - \bar{\mu}) + \gamma(\bar{\beta} - \bar{\tau}) - \Psi_3 \quad (5.73)$$

And the eight Bianchi identities

$$\begin{aligned} D\Psi_1 - \delta^*\Psi_0 &= -3\kappa\Psi_2 + 2(\epsilon + 2\bar{\rho})\Psi_1 + (\pi - 4\sigma)\Psi_0 + [Ricci] \\ D\Psi_2 - \delta^*\Psi_1 &= -2\kappa\Psi_3 + 3\bar{\rho}\Psi_2 + 2(\pi - \alpha)\Psi_1 - \lambda\Psi_0 + [Ricci] \\ D\Psi_3 - \delta^*\Psi_2 &= -\kappa\Psi_4 - 2(\epsilon - \bar{\rho})\Psi_3 + 3\pi\Psi_2 - 2\lambda\Psi_1 + [Ricci] \\ D\Psi_4 - \delta^*\Psi_3 &= -(4\epsilon - \bar{\rho})\Psi_4 + 2(2\pi + \alpha)\Psi_3 - 3\lambda\Psi_2 + [Ricci] \\ \underline{D}\Psi_0 - \delta\Psi_1 &= (4\gamma - \mu)\Psi_0 - 2(2\tau + \beta)\Psi_1 + 3\sigma\Psi_2 + [Ricci] \\ \underline{D}\Psi_1 - \delta\Psi_2 &= \nu\Psi_0 + 2(\gamma - \mu)\Psi_1 - 3\tau\Psi_2 + 2\sigma\Psi_3 + [Ricci] \\ \underline{D}\Psi_2 - \delta\Psi_3 &= 2\nu\Psi_1 - 3\mu\Psi_2 - 2(\tau - \beta)\Psi_3 + \sigma\Psi_4 + [Ricci] \\ \underline{D}\Psi_3 - \delta\Psi_4 &= 3\nu\Psi_2 - 2(\gamma + 2\mu)\Psi_3 - (\tau - 4\beta)\Psi_4 + [Ricci] \end{aligned} \quad (5.74)$$

where the cumbersome Ricci terms have been merely indicated. We may note, however, that by employing the compacted spin coefficient formalism given, for instance, in[42] the Ricci terms also may be exhibited in a direct manner. In the above the notation is standard except that we have used \underline{D} instead of Δ to avoid confusion with the Schwarzschild counterpart of the $\bar{\Delta}$ already figuring in our notation. We note that the $D, \underline{D}, \delta, \delta^*$ are the same as the vector fields $\tilde{l}, \tilde{n}, \tilde{m}, \tilde{\bar{m}}$ respectively, appearing in equations(5.41).

These expressions for the spin coefficients, the Newman-Penrose equations and the Bianchi identities contain, as limiting cases, both the corresponding Kerr and the VES results. As $R \rightarrow \infty$ we recover the Kerr spin coefficients and as $a \rightarrow 0$ we recover the VES counterparts.

Apart from the spin coefficient ϵ which is non-vanishing, $\kappa, \nu, \sigma, \lambda$ do vanish as in the Kerr case. That these are zero shows that the congruence of the principal null directions, l and n are shear-free. In the Kerr case this fact is sufficient to invoke the Goldberg-Sachs theorem to conclude that the Kerr spacetime is of Petrov type-D. In the VEK spacetime, however, in absence of a corresponding theorem, there is no alternative than to evaluate the Weyl scalars. A glance at the Newman-Penrose equations(5.67-5.73) shows that the Weyl scalars Ψ_0 and Ψ_4 vanish straight away. Thus it is immediately clear that the VEK spacetime is type-II. In Chapter 6, Section 6.4 we discuss that this is as it should be by showing that the VEK metric falls into a generalized Kerr-Schild class which therefore correspond to type-II spacetimes. It now remains to see whether Ψ_1 and Ψ_3 also vanish. If they do and if Ψ_2 is the only non-vanishing Weyl scalar and can be evaluated, we would not only have that the spacetime is type-D but also would be enabled to use the expression for Ψ_2 for calculating the Weyl spinor. Here we are prevented from directly verifying this due to the exceedingly cumbersome nature of the computations involved. A way out of this is

to notice that the expressions not containing the mass M do not contribute to the Weyl scalars. Therefore these terms add up to zero. The remaining terms containing M are not so difficult to evaluate and give the result that Ψ_1 and Ψ_3 also vanish. The remaining Weyl scalar Ψ_2 may be calculated in a way analogous to the Kerr case but is cumbersome and we shall not present the details here. Instead we take a brief look at the limiting case of the Kerr spacetime ($R \rightarrow \infty$) and then go on to exhibit, in detail, the classification of the special case of the VES spacetime wherein $a = 0$.

When we take the limit $R \rightarrow \infty$ the vacuum nature of the resulting Kerr spacetime allows us to use the Goldberg-Sachs theorem and put all the Weyl scalars except Ψ_2 to zero. The Ricci terms in the Bianchi identities go to zero. Then the Weyl scalar Ψ_2 is most easily calculated by invoking the Bianchi identities and substituting the Kerr spin coefficients into it as done for instance in [36]. We obtain

$$\begin{aligned} D\Psi_2 &= 3\tilde{\rho}\Psi_2 \\ \delta\Psi_2 &= 3\tau\Psi_2 \end{aligned} \tag{5.75}$$

Rewriting these equations and using the value of $\tilde{\rho}$ and τ we have

$$\begin{aligned} \frac{\partial}{\partial r} \log \Psi_2 &= \frac{-3}{\bar{\rho}_1^*} \\ \frac{\partial}{\partial \theta} \log \Psi_2 &= \frac{-3ia \sin \theta}{\bar{\rho}_1^*} \end{aligned} \tag{5.76}$$

Solving these equations and determining the constant of proportionality from the spin coefficient equations we get

$$\Psi_2 = -M(\bar{\rho}_1^*)^{-3} \tag{5.77}$$

where

$$\bar{\rho}_1^* = r - ia \cos \theta \tag{5.78}$$

As mentioned above a similar calculation of the VEK Weyl scalar requires a knowledge of the non-zero Ricci terms which turn out to have complicated expressions. We turn therefore to the simpler special case of the VES spacetime.

5.5 Classification of the VES Spacetime

As discussed in the previous chapters, the VES spacetime is a special case of the VEK spacetime describing a static, asymptotically non-flat black hole surrounded by matter distribution. It is a well-defined composite spacetime comprising a vacuum black hole spacetime matched to a non-vacuum exterior which, in turn, is matched to the Einstein universe as was done by Nayak, MacCallum and Vishveshwara[3]. This VES black hole contains the Schwarzschild black hole as a limiting case. As the background parameter $R \rightarrow \infty$ the Schwarzschild black hole is recovered.

Since the Schwarzschild black hole is of Petrov type-D it is natural to enquire as to the classification of the VES black hole. As in the VEK case, in the VES case also one cannot invoke a theorem like that of Goldberg and Sachs to determine the Petrov type on the basis of the nature of the spin coefficients alone. We now specialize the spin coefficients obtained in section 5.4 and evaluate the Weyl scalars explicitly. Taking $a = 0$ in equations(5.55) we get

$$\begin{aligned}
\kappa &= \sigma = \lambda = \nu = \epsilon = \pi = \tau = 0 \\
\tilde{\rho} &= -\frac{1}{R \tan(r/R)} \\
\mu &= -\frac{1}{2R \tan(r/R)} \left(1 - \frac{2M}{R \tan(r/R)} \right) \\
\beta &= \frac{\cot \theta}{2\sqrt{2\bar{r}}} \\
\gamma &= \frac{M}{2\bar{r}^2} \\
\alpha &= -\bar{\beta}
\end{aligned} \tag{5.79}$$

These expressions are analogs of the Schwarzschild counterparts given, for instance, in[17]. It is evident that that the Schwarzschild results are recovered as $R \rightarrow \infty$.

The Newman-Penrose equations become

$$D\tilde{\rho} = \tilde{\rho}^2 + \Psi_{00} \tag{5.80}$$

$$0 = \Psi_0 \tag{5.81}$$

$$0 = \Psi_1 + \Phi_{01} \tag{5.82}$$

$$D\alpha = \alpha\tilde{\rho} + \Phi_{10} \tag{5.83}$$

$$D\beta = \beta\tilde{\rho} + \Psi_1 \tag{5.84}$$

$$D\gamma = \Psi_2 + \Phi_{11} - \Lambda \tag{5.85}$$

$$0 = \Phi_{20} \tag{5.86}$$

$$D\mu = \tilde{\rho}\mu + \Psi_2 + 2\Lambda \tag{5.87}$$

$$0 = \Psi_3 + \Phi_{21} \tag{5.88}$$

$$0 = -\Psi_4 \tag{5.89}$$

$$\delta\tilde{\rho} = \tilde{\rho}(\alpha + \beta) - \Psi_1 + \Phi_{01} \tag{5.90}$$

$$\delta\alpha - \delta^*\beta = \mu\tilde{\rho} + \alpha^2 + \beta^2 - 2\alpha\beta - \Psi_2 + \Phi_{11} + \Lambda \tag{5.91}$$

$$-\delta^*\mu = \mu(\alpha + \beta) - \Psi_3 + \Phi_{21} \tag{5.92}$$

$$-\underline{D}\mu = \mu^2 + 2\mu\gamma + \Phi_{22} \tag{5.93}$$

$$\delta\gamma - \underline{D}\beta = \gamma(-\alpha - \beta) + \beta\mu + \Phi_{12} \tag{5.94}$$

$$0 = \Phi_{02} \tag{5.95}$$

$$\underline{D}\tilde{\rho} = -\tilde{\rho}\mu + 2\tilde{\rho}\gamma - \Psi_2 - 2\Lambda \tag{5.96}$$

$$\underline{D}\alpha - \delta^*\gamma = \alpha(\gamma - \mu) + \gamma\beta - \Psi_3 \tag{5.97}$$

Solving the above system of equations and using equations(5.79) we find that

$$\begin{aligned}
\Psi_0 &= 0 \\
\Psi_1 &= D\beta - \beta\tilde{\rho} = \frac{\partial}{\partial r}\beta - \beta\tilde{\rho} = 0 \\
\Psi_2 &= \frac{1}{3}(D\gamma + 2\delta\beta + D\mu + 4\beta^2) = \frac{-M}{R^2 \sin^2(r/R)R \tan(r/R)} \\
\Psi_3 &= \delta\gamma - \underline{D}\alpha - \alpha\mu = 0 \\
\Psi_4 &= 0
\end{aligned} \tag{5.98}$$

And

$$\begin{aligned}
\Phi_{01} &= \Phi_{10} = \Phi_{02} = \Phi_{20} = \Phi_{12} = \Phi_{21} = 0 \\
\Phi_{00} &= \frac{1}{R^2} \\
\Phi_{11} &= \frac{1}{4R^2} \left(1 - \frac{2M}{R \tan(r/R)} \right) \\
\Phi_{22} &= \frac{1}{4R^2} \left(1 - \frac{2M}{R \tan(r/R)} \right)^2 \\
\Lambda &= \frac{1}{4R^2} \left(1 - \frac{2M}{R \tan(r/R)} \right)
\end{aligned} \tag{5.99}$$

Gathering these results together we see first of all from equations(5.98) that apart from Ψ_0 , Ψ_4 , Ψ_1 and Ψ_3 all vanish and the only non-vanishing Weyl scalar is Ψ_2 . This shows that the VES spacetime is Petrov type-D, with repeated principal null directions l and n . By taking the limit $R \rightarrow \infty$ of Ψ_2 it is immediately verified that the VES Weyl scalar reduces to the Schwarzschild counterpart.

Next, turning to the Ricci terms above we see that the only non-vanishing quantities are the components Φ_{00} , Φ_{11} , Φ_{22} and the scalar Λ . The presence of these terms reflect the non-vacuum nature of the VES spacetime. As discussed in Chapter 2, the non-vacuum here refers to matter distribution satisfying reasonable energy conditions.

By taking $M = 0$ in the Ricci terms we see that

$$\begin{aligned}
\Phi_{00} &= \frac{1}{R^2} \\
\Phi_{11} &= \Phi_{22} = \Lambda = \frac{1}{4R^2}
\end{aligned} \tag{5.100}$$

The non-vanishing of these quantities reflect the asymptotically non-flat feature of the VES spacetime. We may recall the the limiting case $M = 0$ of the VES spacetime is the Einstein universe. The asymptotically flat result is recovered in the limit of R tending to infinity and the Ricci quantities vanish as expected.

In passing we note that the optical scalars are given by

$$\begin{aligned}\Theta &= \tilde{\rho} + \bar{\tilde{\rho}} = \frac{-2}{R \tan(r/R)} \\ \omega &= |\tilde{\rho} - \bar{\tilde{\rho}}| = 0 \\ |\sigma\bar{\sigma}| &= 0\end{aligned}\tag{5.101}$$

Thus we have established that the VES spacetime belongs to Petrov class-D. This lends strong support to the expectation that the VEK spacetime also falls into the same class. To our knowledge there is no result which indicates that the Petrov type is preserved in passing from the static to the stationary case. In absence of such a result we base our expectation that the VEK spacetime is also of type-D by considering the fact that firstly, both the limiting case of the Kerr spacetime ($R \rightarrow \infty$) and the special case of the VES spacetime ($a = 0$) are of type-D. Secondly, the existence of the Carter constant also supports this view. Thirdly as we shall discuss in Section 5.6 below, there exists a Newman-Janis type of complex transformation which generates twist in the VES spacetime to give the VEK spacetime. Lastly, as we shall show in Section 5.7, there exists a Killing-Yano tensor which remarkably ‘squares’ to give the Killing tensor. This tensor may be constructed from the Killing spinor which, in turn, is built up from the only non-vanishing Weyl scalar Ψ_2 and the metric spinor ϵ_{AB} . To proceed in these directions we first need to study the 2-spinor formalism to discuss the Killing spinor for the VEK spacetime.

5.6 The Killing Spinor

It is now necessary to recall some essentials of the 2-spinor formalism which provides the frame-work to define the metric and the Killing spinors. For details we refer, for instance, to [42] or [17].

5.6.1 Brief review of the 2-spinor formalism

In the 2-spinor formalism the basic entities are the spinors o^A and ι^A usually normalized by

$$o_A \iota^A = 1\tag{5.102}$$

Most of what follows may be built out of the o^A and ι^A and the above relations.

Indeed, it is helpful to keep the following analogy in mind. In the tensorial view the Newman-Penrose tetrads contain all the information from which the rest of the structures, the metric, the Killing and the Killing-Yano tensors may be expressed. Likewise, the basis spinors o^A and ι^A contain all the information from which the metric and the Killing spinors may be expressed.

The metric spinor ϵ^{AB} which is an antisymmetric spinor is defined by

$$\epsilon^{AB} = o^A \iota^B - \iota^A o^B \quad (5.103)$$

It satisfies the Jacobi identity

$$\epsilon_{A[B\epsilon_{CD]} = 0 \quad (5.104)$$

Just as tensor indices may be raised and lowered with the metric tensor, spinor indices may be so dealt with with the metric spinor. But the position of the indices is also to be given prominence. For instance, we have

$$\begin{aligned} \mu_B &= \epsilon_{AB} \mu^A = \mu^A \epsilon_{AB} \\ \mu^A &= \epsilon^{AB} \mu_B \end{aligned} \quad (5.105)$$

Any spinor $\mu^{A\dots F}$ can be expressed as the sum of the completely symmetrized spinor $\mu^{(A\dots F)}$ and products of the metric spinors with completely symmetric spinors of lower valence.

Thus it is necessary to consider only symmetric spinors.

A Hermitian spinor μ is one for which $\bar{\mu} = \mu$. The covariant constancy of the metric tensor is mirrored by the vanishing of the spinorial covariant derivative of the metric spinor

$$\nabla^{A'} \epsilon_{BC} = 0 \quad (5.106)$$

The 2-spinor formalism is related to the standard tensor formalism through the Infeld-Van der Warden symbols $\sigma^a_{AA'}$ as follows.

The Newman-Penrose tetrad is defined in terms of o^A and ι^A by

$$\begin{aligned} l^a &= \sigma^a_{AA'} o^A o^{A'} \\ n^a &= \sigma^a_{AA'} \iota^A \iota^{A'} \\ m^a &= \sigma^a_{AA'} o^A \iota^{A'} \\ \bar{m}^a &= \sigma^a_{AA'} \iota^A o^{A'} \end{aligned} \quad (5.107)$$

The normalization relations obeyed by the null tetrad follow naturally from the relations(5.102). By convention the Infeld-Van der Warden symbols are usually not written explicitly. They are inserted when needed for calculational purposes.

Thus, for example, the relation between the metric tensor and the metric spinor is written simply as

$$g_{ab} = \epsilon_{AB} \epsilon_{A'B'} \quad (5.108)$$

In addition to these other quantities there are that coming from the spinor decomposition of the Riemann tensor.

The Riemann tensor has the spinor expression

$$R_{abcd} = X_{ABCD}\epsilon_{A'B'}\epsilon_{C'D'} + \Phi_{ABC'D'}\epsilon_{A'B'}\epsilon_{CD} + \bar{\Phi}_{A'B'C'D'}\epsilon_{AB}\epsilon_{C'D'} + \bar{X}_{A'B'C'D'}\epsilon_{AB}\epsilon_{CD} \quad (5.109)$$

where

$$\begin{aligned} X_{ABCD} &= X_{(AB)(CD)} \\ \Phi_{ABC'D'} &= \Phi_{(AB)(C'D')} \end{aligned} \quad (5.110)$$

and

$$\begin{aligned} X_{ABCD} &= X_{CDAB} \\ \bar{\Phi}_{ABC'D'} &= \bar{\Phi}_{ABC'D'} \end{aligned} \quad (5.111)$$

Along with this we have the scalar Λ

$$\Lambda = \frac{1}{6}X_{AB}{}^{AB} \quad (5.112)$$

so that

$$X_{ABC}{}^B = 3\Lambda\epsilon_{AC}\Lambda = \bar{\Lambda} \quad (5.113)$$

This is an expression of the identity

$$R_{a[bcd]} = 0 \quad (5.114)$$

We further have

$$\begin{aligned} R &= 24\Lambda \\ R_{ab} &= 6\Lambda g_{ab} - 2\Phi_{ab} \end{aligned} \quad (5.115)$$

In terms of these quantities the Einstein field equations become

$$\begin{aligned} \Phi_{ab} &= 4\pi(T_{ab} - \frac{1}{4}T_c{}^c g_{ab}) \\ \Lambda &= \frac{1}{3}\pi T_c{}^c \end{aligned} \quad (5.116)$$

The Weyl spinor Ψ_{ABCD} is defined as the symmetric part of X_{ABCD}

$$\Psi_{ABCD} = X_{(ABCD)} = X_{A(BCD)} \quad (5.117)$$

We have

$$X_{ABCD} = \Psi_{ABCD} + \Lambda(\epsilon_{AC}\epsilon_{BD} + \epsilon_{AD}\epsilon_{BC}) \quad (5.118)$$

The full Riemann tensor(5.109) becomes

$$\begin{aligned} R_{abcd} &= \Psi_{ABCD}\epsilon_{A'B'}\epsilon_{C'D'} + \Psi_{A'B'C'D'}\epsilon_{AB}\epsilon_{CD} + \Phi_{ABC'D'}\epsilon_{A'D'}\epsilon_{CB} \\ &\quad + \bar{\Phi}_{A'B'C'D'}\epsilon_{AB}\epsilon_{C'D'} + 2\Lambda(\epsilon_{AC}\epsilon_{BD}\epsilon_{A'C'}\epsilon_{B'D'} - \epsilon_{AD}\epsilon_{BC}\epsilon_{A'D'}\epsilon_{B'C'}) \end{aligned} \quad (5.119)$$

The terms involving Ψ_{ABCD} alone give the Weyl tensor

$$C_{abcd} = \Psi_{ABCD}\epsilon_{A'B'}\epsilon_{C'D'} + \bar{\Psi}_{A'B'C'D'}\epsilon_{AB}\epsilon_{CD} \quad (5.120)$$

The Bianchi identity

$$R_{ab[cd;e]} = 0 \quad (5.121)$$

becomes

$$\nabla_{B'}^A X_{ABCD} = \nabla_B^{A'} \Phi_{CDA'B'} \quad (5.122)$$

Or

$$\begin{aligned} \nabla_{B'}^A \Psi_{ABCD} &= \nabla_{(B}^{A'} \Phi_{CD)A'B'} \\ \nabla^{CA'} \Phi_{CDA'D'} &= -3\nabla_{DB'} \Lambda \end{aligned} \quad (5.123)$$

This shows that when the vacuum Einstein field equations hold

$$\begin{aligned} \Phi_{ABC'D'} &= 0 \\ \Lambda &= 0 \end{aligned} \quad (5.124)$$

We have

$$\nabla^{AA'} \Psi_{ABCD} = 0 \quad (5.125)$$

And when matter is present there is a source term

$$\nabla^A B' \Psi_{ABCD} = 4\pi \nabla_{(B}^{A'} T_{CD)A'B'} \quad (5.126)$$

Equation(5.125) plays an important role in the existence of the Killing spinor for the Kerr spacetime.

In passing we note that the Newman-Penrose Weyl scalars are given in terms of the spinor basis o^A and ι^A by

$$\begin{aligned} \Psi_0 &= \Psi_{ABCD} o^A o^B o^C o^D \\ \Psi_1 &= \Psi_{ABCD} o^A o^B o^C \iota^D \\ \Psi_2 &= \Psi_{ABCD} o^A o^B \iota^C \iota^D \\ \Psi_3 &= \Psi_{ABCD} o^A \iota^B \iota^C \iota^D \\ \Psi_4 &= \Psi_{ABCD} \iota^A \iota^B \iota^C \iota^D \end{aligned} \quad (5.127)$$

The Ricci quantities are defined analogously. We now define the Killing spinor

5.6.2 The Killing spinor

A Killing spinor $\xi^{A\dots DK'\dots N'}$ is a symmetric spinor with r primed and s unprimed indices which satisfies

$$\nabla_Q^P \xi_{K\dots N}^{A\dots D} = 0 \quad (5.128)$$

As the terminology and the definition suggests, $\xi^{A...DK'...N'}$ is associated with a conserved quantity. To see this we need to contract $\xi^{A...DK'...N'}$ with a spinor analogue of a geodesic-vector and take the covariant derivative. For this we take a null vector p^a which may always be written in the spinor form $p^a = \bar{\pi}^A \pi'^a$ and contract $\xi^{A...DK'...N'}$ with the $\bar{\pi}^A \pi'^a$ s. Then demanding that

$$p^a \nabla_a \pi^{A'} = 0 \quad (5.129)$$

which essentially means that the flag plane of the spinor $\pi^{A'}$ is also parallelly propagated, the quantity

$$Q = \xi^{A...DK'...N'} \bar{\pi}_A \dots \bar{\pi}_D \pi_{Y'} \pi_{K'} \dots \pi_{N'} \quad (5.130)$$

is conserved. Indeed, taking the covariant derivative of Q we have

$$\begin{aligned} p^y \nabla_y Q &= p^y \nabla_y \xi^{A...DK'...N'} \bar{\pi}_A \dots \pi_{N'} = \nabla^{YY'} (\bar{\pi}_A \dots \bar{\pi}_D \pi_{Y'} \pi_{K'} \dots \pi_{N'}) \xi^{A...N'} \\ &\quad + \bar{\pi}_A \dots \bar{\pi}_D \pi_{Y'} \pi_{K'} \dots \pi_{N'} \nabla^{YY'} \xi^{A...N'} = 0 \end{aligned} \quad (5.131)$$

The first term vanishes due to parallel propagation of the flag plane of $\pi^{A'}$ (5.129) and the second term vanishes by the definition of the Killing spinor (5.128). This property of the Killing spinor may be compared and contrasted with that of the Killing tensor (5.21). Apart from the similarities, the additional requirement here is that the flag plane of $\pi^{A'}$ vanish and that the Killing spinor need not be symmetric in the primed and unprimed indices, ie, $r \neq s$. When $r = s$ the Killing spinor is Hermitian and Q is then a real conserved quantity essentially equivalent to the Carter constant for null geodesics. When $r \neq s$ however, the Killing spinor is complex and therefore, Q is also complex. It contains additional information related to the flag plane of $\pi^{A'}$ also. This information enables one to determine the propagation of polarization planes along null geodesics. Thus when the Killing spinor is complex, one cannot give it a direct interpretation associating it with a physical conserved quantity. Then one extracts a real quantity from Q by considering the quantity $|Q|$ by defining $\tilde{Q} = Q\bar{Q}$ after obtaining the solution of Q [31]. Another method, which is the one relevant to our purpose, is to obtain an indirect interpretation by using the Killing spinor, along with the metric spinor, to build up the Killing-Yano tensor. This is because the Killing spinor of a type-D spacetime is essentially complex as we now discuss.

From here onwards we shall be interested in the particular Killing spinors that is associated with the type-D nature of the spacetime. In type-D spacetimes there exists a symmetric spinor of valence two given by

$$\kappa_{AB} = \Psi_2^{-1/3} o_{(A} \iota_{B)} \quad (5.132)$$

By the definition (5.128) this satisfies

$$\nabla_{(A}^{A'} \kappa_{BC)} = 0 \quad (5.133)$$

This is to be contrasted with the definition of the metric spinor (5.103) which may be written in an equivalent form

$$\epsilon_{AB} = 2o_{[A} \iota_{B]} \quad (5.134)$$

and whose covariant derivative also vanishes.

This shows that the metric spinor is trivially a Killing spinor.

The metric spinor naturally exists for any spacetime. However, the existence of the Killing spinor κ_{AB} , as shown by Walker and Penrose, is intimately related to the type-D character of the spacetime. This has to do with the fact that κ_{AB} is, apart from the basis spinors o^A and ι^A , a multiple of the Weyl scalar Ψ_2 . Thus whereas ϵ_{AB} exists in any spacetime, including the case of the flat spacetime, the existence of κ_{AB} is restricted to type-D spacetimes. Indeed, from the definition(5.132) it is clear that on the one hand κ_{AB} as is defined is a Killing spinor only when Ψ_2 is the only non-vanishing Weyl scalar. On the other hand, it vanishes not only in flat spacetime but even for a conformally-flat spacetime such as, for instance, the Einstein universe. The latter feature is significant in that it allows for an extension of the Killing spinor from the asymptotically flat Kerr spacetime to that of the asymptotically non-flat VEK spacetime.

Coming back to equation(5.133), in the Kerr case, Walker and Penrose base their proof on the vacuum Bianchi identity(5.125). As stated in ref[42] the proof consists in rearranging the Bianchi identity equation(5.125) so that it becomes (5.133). Thus there exists an explicit complex conserved quantity along any null geodesic in a vacuum type-D spacetime.

After this review of the standard results we move on to the VEK spacetime.

5.6.3 Killing spinor and the VEK spacetime

The above discussion on the Killing spinor had two important assumptions. One is that the spacetime is of type-D. Another is that, in addition, the spacetime is of vacuum. The former is true in the VEK case also and ensures that the only non-zero Weyl scalar is Ψ_2 . The latter seems to restrict the existence of the Killing spinor as when the spacetime is of non-vacuum one no longer has the vacuum Bianchi identity(5.125) but rather the equation(5.126). Thus one is not certain whether equation(5.133) holds for the non-vacuum case also. Nevertheless, basing our expectations on the results obtained thus far, which strongly indicate that most of the standard Kerr results go through for the VEK case also, apart from subtle, non-trivial modifications we assume that equation(5.133) holds. Even if this would not be true, it might not be improbable that there exists a redefined Killing spinor which does satisfy equation(5.133). However, we do not pursue this point further in this thesis. We may remark that it is the existence of such unresolved issues, viz, how strong is the relation between the properties of the geodesics and the classification of the spacetime when the assumption of vacuum and asymptotic flatness is relaxed, which makes the present investigations so significant and pressing.

We now proceed to construct the Killing spinor κ_{AB} for the VEK spacetime.

The definition of a Killing spinor for a type-D spacetime has been given in equation(5.132) above. In order to construct it explicitly one needs the Weyl scalar Ψ_2 and also the basis spinors o^A and ι^A . The basis spinors may be obtained from the Newman-Penrose tetrad form l once a suitable choice of the Infeld-Vander Warden symbols is made. We note that the expression for the Killing spinor contains the product of the basis spinors o_A and ι_B which is all we need evaluate.

It is convenient to perform the following computations by going over to generalized Kerr-Schild coordinates. This makes it possible also to obtain the expression for the VEK Weyl scalar via a Newman-Janis complex algorithm. Since in Chapter 6 we shall treat the generalized Kerr-Schild approach, we refer to that chapter for the details. Here we note that the generalized Kerr-Schild transformation is given by

$$\begin{aligned} du &= dt - \frac{\bar{r}^2 + a^2}{\Delta} dr \\ d\phi &= d\bar{\phi} - \frac{a}{\Delta} dr \end{aligned} \quad (5.135)$$

The tetrad forms(5.36) now become

$$\begin{aligned} e^0 &= \frac{\bar{\Delta}}{\bar{\rho}} (du - a \sin^2 \theta d\bar{\phi}) - \frac{\bar{\rho}^2}{\Delta} \\ e^1 &= \frac{\bar{\rho}}{\Delta} dr \\ e^2 &= \frac{\bar{\rho}}{\zeta} d\theta \\ e^3 &= \frac{\sin \theta}{\bar{\rho}} ((\bar{r}^2 + a^2) d\bar{\phi} - a du) \end{aligned} \quad (5.136)$$

We may pick out the tetrad coefficients e_a^A from the relation

$$e^A = e_a^A dx^a \quad (5.137)$$

The Infeld-Van Der Warden symbols can be chosen from the tetrad coefficients to be

$$\sigma_0^{A\dot{B}} = \frac{1}{\sqrt{2}(1 - \frac{2M\bar{r}}{\bar{\rho}^2})} \begin{pmatrix} 1 & 0 \\ 0 & 1 \end{pmatrix}. \quad (5.138)$$

$$\sigma_1^{A\dot{B}} = \frac{1}{\sqrt{2}} \begin{pmatrix} -\frac{\sqrt{\bar{\Delta} + a \sin \theta}}{1 - \frac{2M\bar{r}}{\bar{\rho}^2}} & \frac{\bar{\rho}}{\sqrt{\bar{\Delta}}} \\ \frac{\bar{\rho}}{\sqrt{\bar{\Delta}}} & \frac{\sqrt{\bar{\Delta} - a \sin \theta}}{1 - \frac{2M\bar{r}}{\bar{\rho}^2}} \end{pmatrix}. \quad (5.139)$$

$$\sigma_2^{A\dot{B}} = \frac{\bar{\rho}}{\sqrt{2}\zeta} \begin{pmatrix} 0 & i \\ -i & 0 \end{pmatrix}. \quad (5.140)$$

$$\sigma_a^{A\dot{B}} = \frac{\sin \theta}{\sqrt{2}(1 - \frac{2Mr}{\bar{\rho}^2})} \begin{pmatrix} \frac{2Mr a \sin \theta}{\bar{\rho}^2} + \sqrt{\Delta} & 0 \\ 0 & \frac{2Mr a \sin \theta}{\bar{\rho}^2} - \sqrt{\Delta} \end{pmatrix}. \quad (5.141)$$

By means of the $\sigma_a^{A\dot{B}}$ and the relation

$$l^A \bar{l}^{\dot{B}} = \sigma_a^{A\dot{B}} l_a \quad (5.142)$$

we find the expression for the Killing spinor to be

$$\kappa_{AB} = \frac{\Psi_2^{-1/3}}{2\bar{\rho}\sqrt{1 - \frac{2Mr}{\bar{\rho}^2}}} \begin{pmatrix} \sqrt{\Delta} - a \sin \theta & 0 \\ 0 & \sqrt{\Delta} + a \sin \theta \end{pmatrix}. \quad (5.143)$$

It remains to find the Weyl scalar. To obtain it we proceed from expression for the VES Weyl scalar given in equation(5.98) and rewrite it as

$$\Psi_2^{-1/3} = \frac{-M \cos(r/R)}{R^3 \sin^3(r/R)} \quad (5.144)$$

The Newman-Janis algorithm amounts to making the complex transformation

$$R \sin(r/R) \rightarrow (R \sin(r/R)) + i\chi a \cos \theta \quad (5.145)$$

where

$$\chi = \sqrt{1 - \frac{\sin^2(r/R)}{\cos^2 \theta}} \quad (5.146)$$

Under this transformation Ψ_2 becomes

$$\Psi_2^{1/3} = \frac{-M \cos(r/R)}{\sqrt{R^2 - a^2 \sin(r/R) + i \cos(r/R) a \cos \theta}} \quad (5.147)$$

This reduces to the special case of the VES Weyl scalar as $a = 0$ and the limiting Kerr Weyl scalar as $R \rightarrow \infty$.

The Weyl scalar Ψ_2 vanishes when $M = 0$. Thus it is not possible to make use of it for the case $M = 0$. In most work involving the Weyl scalar as applied to the study of particle angular momentum, as for instance, by Faridi[34], M is scaled off. Following the same procedure we use instead of Ψ_2 given in the above equation, the quantity Ψ given by

$$\Psi^{1/3} = \frac{-\cos(r/R)}{\sqrt{R^2 - a^2 \sin(r/R) + i \cos(r/R) a \cos \theta}} \quad (5.148)$$

Substituting this in equation(5.143) we arrive at the expression for the Killing spinor of the VEK spacetime as

$$\kappa_{AB} = -\frac{\sqrt{R^2 - a^2 \sin(r/R) + i \cos(r/R) a \cos \theta}}{2\bar{\rho} \cos(r/R) \sqrt{1 - \frac{2Mr}{\bar{\rho}^2}}} \begin{pmatrix} \sqrt{\Delta} - a \sin \theta & 0 \\ 0 & \sqrt{\Delta} + a \sin \theta \end{pmatrix} \quad (5.149)$$

This may be written in compact form using our notation as

$$\kappa_{AB} = -\frac{\bar{r} + i \cos(r/R)a \cos \theta}{2\bar{\rho} \cos(r/R) \sqrt{1 - \frac{2Mr}{\rho^2}}} \begin{pmatrix} \sqrt{\Delta} - a \sin \theta & 0 \\ 0 & \sqrt{\Delta} + a \sin \theta \end{pmatrix} \quad (5.150)$$

This expression contains both the special case($a = 0$) of the VES Killing spinor and the limiting case($R \rightarrow \infty$) of the VEK Killing spinor

The VES Killing spinor is given by

$$\kappa_{AB} = -\frac{R^3 \sin^2(r/R) \tan(r/R)}{\sqrt{1 - \frac{2M}{R \tan(r/R)}}} \begin{pmatrix} \sqrt{\Delta} & 0 \\ 0 & \sqrt{\Delta} \end{pmatrix} \quad (5.151)$$

And the Kerr Killing spinor is given by

$$\kappa_{AB} = -\frac{r + ia \cos \theta}{2\rho \sqrt{1 - \frac{2Mr}{\rho^2}}} \begin{pmatrix} \sqrt{\Delta} - a \sin \theta & 0 \\ 0 & \sqrt{\Delta} + a \sin \theta \end{pmatrix} \quad (5.152)$$

Having constructed κ_{AB} for the VEK spacetime, some remarks are in order.

In the Kerr case, proceeding along the above lines Hughston and Sommers[43] have shown that for any vacuum spacetime possessing a Killing spinor χ^{AB} there exists a (complex) Killing vector k^a given by

$$k^a = \nabla_B^{A'} \chi^{AB} \quad (5.153)$$

They have further shown[42] that this vector satisfies the relations $k_{(a;b)} = 0$ without invoking the vacuum assumption. Moreover Floyd[30] and Penrose[32] have shown that in the Kerr spacetime the Killing vector k^a which arises out of the Killing spinor κ_{AB} implies that the bivector

$$F_{ab} = i(\kappa_{AB} \epsilon_{A'B'} - \epsilon_{AB} \kappa_{A'B'}) \quad (5.154)$$

satisfies

$$F_{a(b;c)} = 0 \quad (5.155)$$

The bivector F_{ab} is identified as the Killing-Yano tensor. We base our work on the same expression with the Kerr quantities replaced by the VEK counterparts.

5.7 The Killing-Yano Tensor

The Killing-Yano tensor is an antisymmetric tensor or a differential form which satisfies

$$F_{a(b\dots cd;e)} = 0 \quad (5.156)$$

As with the Killing tensor and the Killing spinor, the Killing-Yano tensor is associated with a conserved quantity. Indeed taking the covariant derivative of the expression

$$J_a = F_{ab\dots cd} p^b \dots p^c p^d \quad (5.157)$$

we have

$$p^e(J_{a;e}) = p^e p^{b;e} \dots p^c p^d F_{ab\dots cd} + \dots F_{ab\dots cd;e} p^e p^b \dots p^c p^d = 0 \quad (5.158)$$

The terms other than the last vanish due to the geodesic equations and the last term vanishes by the definition of the Killing-Yano tensor(5.156).

Since we shall be interested only in a Killing-Yano tensor of rank two, we shall confine ourselves to it. The above definition(5.156) then reduces to

$$F_{a(b;c)} = 0 \quad (5.159)$$

The associated conserved quantity is then

$$J^b = F_a{}^b p^a \quad (5.160)$$

That is, J^a is a conserved vector field. This property plays a key role in defining an angular momentum-like structure for the VEK spacetime, naturally subsuming the Kerr case. It is now necessary to obtain an explicit expression for F_{ab} in the VEK case.

Employing the definition(5.154) and substituting the expression for the Killing spinor(5.152) into it, it is straight-forward to calculate F_{ab} component-wise. We find that

$$F_{ab} = \begin{pmatrix} 0 & -a \cos \theta & \frac{a\bar{r} \sin \theta}{\zeta} & 0 \\ a \cos \theta & 0 & 0 & -a^2 \sin^2 \theta \cos \theta \\ -\frac{a\bar{r} \sin \theta}{\zeta} & 0 & 0 & \frac{\bar{r}(\bar{r}^2 + a^2) \sin \theta}{\zeta} \\ 0 & a^2 \sin^2 \theta \cos \theta & -\frac{\bar{r}(\bar{r}^2 + a^2) \sin \theta}{\zeta} & 0 \end{pmatrix} \quad (5.161)$$

Or

$$\begin{aligned} F &= \frac{1}{2} F_{ab} dx^a \wedge dx^b \\ &= -a \cos \theta (du - a \sin^2 \theta d\phi) \wedge dr + \frac{\bar{r}}{\zeta} \sin \theta (adt - (\bar{r}^2 + a^2) d\phi) \wedge d\theta \end{aligned} \quad (5.162)$$

The contravariant form of the Killing-Yano tensor is given by

$$F^{ab} = \begin{pmatrix} 0 & \frac{a \cos \theta (\bar{r}^2 + a^2)}{\bar{\rho}} & \frac{-a\bar{r} \sin \theta \zeta}{\bar{\rho}^2} & 0 \\ -\frac{a \cos \theta (\bar{r}^2 + a^2)}{\bar{\rho}} & 0 & 0 & \frac{-a^2 \cos \theta}{\bar{\rho}^2} \\ \frac{a\bar{r} \sin \theta \zeta}{\bar{\rho}^2} & 0 & 0 & \frac{\zeta \bar{r}}{\bar{\rho}^2 \sin \theta} \\ 0 & \frac{a^2 \cos \theta}{\bar{\rho}^2} & \frac{-\zeta \bar{r}}{\bar{\rho}^2 \sin \theta} & 0 \end{pmatrix} \quad (5.163)$$

Taking the limit $R \rightarrow \infty$ we recover the Killing-Yano tensor for the Kerr spacetime. It is easily seen that the resulting expression coincides with the one given, for instance, in Faridi [34].

$$F_{ab} = \begin{pmatrix} 0 & -a \cos \theta & ar \sin \theta & 0 \\ a \cos \theta & 0 & 0 & -a^2 \sin^2 \theta \cos \theta \\ -ar \sin \theta & 0 & 0 & r(r^2 + a^2) \sin \theta \\ 0 & a^2 \sin^2 \theta \cos \theta & -r(r^2 + a^2) \sin \theta & 0 \end{pmatrix} \quad (5.164)$$

Or

$$\begin{aligned}
 F &= \frac{1}{2} F_{ab} dx^a \wedge dx^b \\
 &= -a \cos \theta (du - a \sin^2 \theta d\phi) \wedge dr + \frac{\bar{r}}{\zeta} \sin \theta (adt - (\bar{r}^2 + a^2) d\phi) \wedge d\theta \quad (5.165)
 \end{aligned}$$

Taking $a = 0$ in(5.161) we recover the VES expression

$$F_{ab} = \begin{pmatrix} 0 & 0 & 0 & 0 \\ 0 & 0 & 0 & 0 \\ 0 & 0 & 0 & R \sin^3(r/R) \sin \theta \\ 0 & 0 & -R \sin^3(r/R) \sin \theta & 0 \end{pmatrix} \quad (5.166)$$

Or

$$F = \frac{1}{2} F_{ab} dx^a \wedge dx^b = R \sin^3(r/R) \sin \theta d\phi \wedge d\theta \quad (5.167)$$

Having obtained the Killing-Yano tensor we have constructed the key quantities which are associated directly or indirectly, with the Carter constant and the type-D nature of the VEK spacetime.

5.8 Concluding Remarks

In this chapter we have focused on a study of the Carter constant and the classification of the spacetime via the Newman-Penrose formalism. In the Kerr spacetime much of this is well established. The VEK spacetime on which we have based our investigations has an additional feature in that it describes a non-vacuum asymptotically non-flat rotating black hole. The black hole is surrounded by matter distribution which satisfies reasonable energy conditions.

Starting with a discussion of Carter's discovery of the fourth constant in the Kerr case, we have shown by construction that the Carter constant exists in the VEK spacetime also. From the Carter constant we have obtained the Killing tensor and brought out its significance by considering the special case of the Schwarzschild spacetime wherein the Killing tensor becomes reducible.

Next, taking into account the fact that in the Kerr spacetime, the Killing tensor is related to the Killing-Yano tensor which, in turn, is related to the type-D nature of the spacetime, we have investigated the classification of the VEK spacetime. By employing the Newman-Penrose formalism we have calculated the spin coefficients for the VEK spacetime. We have shown that unlike the Kerr case there is a non-vanishing spin coefficient ϵ . Even though the rest of the results mirror that in the Kerr case, their expressions are considerably complicated. These spin coefficients contain as limiting cases the Kerr and the VES counterparts and of course the Schwarzschild ones also. The Bianchi identities

contain non-zero Ricci terms also in addition to the Weyl scalars.

Motivated by the significance of the type-D nature of a black hole spacetime we have studied the classification of the VEK spacetime. We have demonstrated explicitly and in detail, that the VES spacetime is type-D. We have shown that the only non-vanishing Weyl scalar is Ψ_2 . Turning to the Ricci terms, the only non-zero terms are Φ_{00} , Φ_{11} , Φ_{22} and the scalar Λ . That these terms which vanish in the Schwarzschild case do not do so here shows that the spacetime is non-vacuum. In the Einstein universe also the Ricci terms are non-zero which brings out the asymptotically non-flat nature of the spacetime. The optical scalars ω and σ vanish as in the Schwarzschild case whereas the optical scalar Θ is modified because of the background.

We have discussed the 2-spinor formalism and constructed the Killing spinor for the VEK spacetime. By means of the Killing spinor we have calculated the Killing-Yano tensor and shown that in the limit $R \rightarrow \infty$ this coincides with the Killing-Yano tensor of the Kerr spacetime.

With this we have not only brought out the essential features of the VEK spacetime associated with the separability properties and the Petrov classification but also constructed the quantities that go into supporting an angular momentum structure as we shall see in the following chapter.

**BLACK HOLES
IN
COSMOLOGICAL BACKGROUNDS**

*A thesis
submitted for the degree of
Doctor of Philosophy
in the Faculty of Science
University of Calicut, India*

B. S. Ramachandra

**Indian Institute of Astrophysics
Bangalore, India**

March 2003

Chapter 6

Geodetic Particle Angular Momentum in the VEK Spacetime

6.1 Introduction

In the present chapter we deploy the geometrical quantities constructed in Chapter 5 to the investigation of their relation to a possible angular momentum-like structure in the VEK spacetime defined by the Killing-Yano tensor. As in Chapter 5, these studies involve an interplay of diverse concepts. These are the structure of the Killing and the Killing-Yano tensors, the generalized Kerr-Schild transformation and the background-black hole decomposition. We set up the stage for a fruitful study of these topics in the non-vacuum, asymptotically non-flat VEK spacetime. Thus the results obtained not only give insights into the nature of the VEK spacetime but to the limiting case of the Kerr spacetime also. We begin by giving a simplified account of the phase-space or symplectic formalism given in an unpublished preprint by Samuel and Vishveshwara[33]. We shall employ this approach throughout this chapter. An alternative approach to the investigation of particle angular momentum in the Kerr spacetime has been given by Faridi [34].

In the previous chapter we have investigated the separability properties of the geodesics and the classification of the spacetime. The remarkable fact is that the two lines of investigation both lead to the Carter constant. This makes the problem of interpretation of the Carter constant particularly interesting as it does not admit any clear physical interpretation. Some work related to such interpretation relevant to our present investigations is that of Samuel and Vishveshwara[33] and Faridi[34]. It is well-known that in the limiting case of the Schwarzschild spacetime, the Carter constant reduces to the square of the particle angular momentum. Taking this clue, Samuel and Vishveshwara suggested a definition for the angular momentum about any axis for a particle in geodesic motion around a Kerr black hole. They showed that a physically reasonable definition was indeed possible based on a natural separation of the Hamiltonian into two parts, a kinetic part admitting a large symmetry group and a potential part with a smaller symmetry group. They showed that their definition of angular momenta satisfied the bracket relations expected of them. Fur-

ther, they calculated the precession of the angular momentum vector to first order in the angular momentum parameter a .

Faridi gave a construction of the Killing-Yano tensor for the Kerr metric and obtained the Carter constant. He showed that the Killing-Yano tensor was related to the angular momentum of Newtonian mechanics. The equation of precession has a non-trivial solution only for the case of a slowly rotating Kerr black hole valid to first order in the angular momentum parameter a . This led him to interpret the Carter constant as the squared length of the precessing angular momentum vector.

Turning to our present investigation of the particle angular momentum in the VEK spacetime we may make the following observations. In curved spacetime, the definition of physical quantities is non-trivial due to the absence of an isometry group as in the flat spacetime. In the flat spacetime the Poincare group allows us to define the energy, momentum and angular momentum for a free particle. The momentum of the particle can be identified as the generator of spatial translations, the energy as the generator of time translation and the angular momentum as the generator of rotations. Due to the natural action of the Poincare group on Minkowski spacetime, there is a meaningful notion of a global translation or rotation. In a general curved spacetime however, it is not possible to define any of these quantities in a natural manner. Nevertheless, in a stationary, axisymmetric spacetime the isometries associated with the Killing vectors do enable us to define physically significant quantities which are conserved. In the special case of the static spherically symmetric spacetime, it is possible to define the energy and the three components of the angular momentum about the centre of symmetry using the timelike Killing vector field. These quantities are conserved in the motion and asymptotically coincide with their flat counterparts. In the stationary, axisymmetric case of the Kerr spacetime only the energy and the angular momentum about the axis of symmetry can be defined. This is due to the absence of a natural action of the full rotation group on an axisymmetric spacetime.

Thus it appears that in a curved spacetime, physical quantities can be defined only when they are conserved. In the absence of such a criterion, one does not have any clue as to how to construct such quantities. This is contrary to the situation in the flat spacetime. There, for instance, due to the existence of the Poincare group, it is possible to define the angular momentum of a particle in a potential which is not spherically symmetric, even though it is not conserved. This definition relies on the separation of the Hamiltonian into a 'kinetic' and a 'potential' term. The first is spherically symmetric and depends only on the metric and not on the potential. The second term is the potential term which is not spherically symmetric. The first has a large symmetry group whereas the second has a smaller one. The kinetic part of the Hamiltonian may be used to define physical quantities like the angular momentum. Though it is not conserved in the motion, it can be meaningfully defined.

In the static, spherically symmetric Schwarzschild spacetime, we may define physical quantities by an analogous separation of the Hamiltonian into a kinetic and a potential part. This is due to the separation of the metric into a background and a black hole term called the background black hole decomposition introduced by Ramachandra and Vishveshwara[21] as discussed in Chapter 2. In the Kerr spacetime such a separation is possible by going over into the Kerr-Schild coordinates. Thus in the Kerr spacetime, a physically reasonable definition of the angular momentum may be given as shown by Samuel and Vishveshwara. As already mentioned their definition is based on the Killing-Yano tensor.

Therefore, in view of the above discussion, it would seem that defining the particle angular momentum in the VEK spacetime is far from trivial. It is well known that even in the Kerr spacetime such a definition is not at all straight-forward. There, attempts have been made to relate the Killing and the Killing-Yano tensors to particle angular momentum but still, a complete clarification of the role of these quantities is lacking. In this chapter it is our intention to investigate some of these issues in the context of the non-vacuum, asymptotically non-flat VEK spacetime.

As usual we recover the Kerr results as limiting cases of the VEK counterparts.

As has been pointed out in Chapter 3, we recall that when we speak here of conserved quantities like ‘mass’, ‘energy’ and ‘angular momentum’ in the VEK spacetime we really mean that these quantities have as limiting cases their usual counterparts defined in an asymptotically flat spacetime. We shall continue to call these as simply mass, energy and angular momentum respectively for convenience.

The present chapter is organized as follows. In Section 6.2, we discuss the phase space formalism and show how to project quantities on spacetime to space. In Section 6.3, we discuss the relation between the Killing and the Killing-Yano tensors. We show that the Killing-Yano tensor constructed in Chapter 5 leads to exactly the Killing tensor. After a brief discussion on the Killing tensor, we discuss the significance of the Killing-Yano tensor. In Section 6.4, we discuss the background black hole decomposition for the quantities in the VEK spacetime as was done in the VES case in Chapter 2. In Section 6.5, we use the Killing-Yano tensor to define vector fields which satisfy the bracket relations and can be considered as analogues of the generators of particle angular momentum and discuss the corresponding bracket relations. We present calculations on the precession of particle angular momentum to first order in the angular momentum parameter a . Section 6.6 carries some concluding remarks.

6.2 The Phase Space Formalism

Along with purely geometrical methods the use of Lagrangian and Hamiltonian methods in General Relativity has been wide-spread since the beginning of the subject itself. In the study of geodesics one employs these or the Hamilton-Jacobi method. Depending on the situation, one or the other approach may be found more suitable in carrying on the investigations. In the present case we have found the Hamiltonian or phase space approach to be convenient for our studies.

The phase space or symplectic formalism allows one to deal with scalar analogues of the corresponding tensors. These scalars are obtained by contracting the tensors with geodesic vector fields. Thus, for instance, one avoids dealing with the Lie derivative and the connection coefficients. Instead, one has only to deal with the Poisson bracket.

This formalism also enables us to project tensors on spacetime to tensors on space. Moreover, it is independent of the existence of a metric on the spacetime. It differs from the Geroch formalism which employs the metric tensor to project tensors onto the hypersurface orthogonal to the time-like Killing vector field.

Let \mathcal{C} be the configuration space, ξ^a a vector field on \mathcal{C} and $\tilde{\mathcal{C}}$ be the 3-manifold of the flow of ξ^a . Then there exists a natural mapping

$$\pi : \mathcal{C} \rightarrow \tilde{\mathcal{C}} \quad (6.1)$$

which assigns each point of \mathcal{C} to the flow of ξ^a on which it lies. By means of this mapping various geometrical quantities may be projected onto $\tilde{\mathcal{C}}$. The only quantities relevant to our work are functions, vector fields and forms.

A function f on \mathcal{C} is projectible if there exists a function \tilde{f} on $\tilde{\mathcal{C}}$ from which f is obtained by pulling \tilde{f} to \mathcal{C}

$$f = \tilde{\pi}^* \tilde{f} \quad (6.2)$$

This implies f is preserved by the flow of ξ and satisfies

$$\mathcal{L}_\xi f = 0 \quad (6.3)$$

In coordinate form this may be written as

$$\frac{\partial f}{\partial x^0} = 0 \quad (6.4)$$

Next, a vector field X is projectible if $X(f)$ is a projectible function provided f is also projectible. That is

$$\mathcal{L}_\xi X(f) = \mathcal{L}_\xi(i_X df) = i_{[\xi, X]} df + i_X d\mathcal{L}_\xi f = 0 \quad (6.5)$$

The second term vanishes since f is projectible. Here we have made use of the relation

$$\mathcal{L} = i_X d + di_X \quad (6.6)$$

Therefore the condition becomes

$$(\mathcal{L}_\xi X)f = 0 \quad (6.7)$$

This tells us that $\mathcal{L}_\xi X$ is a vertical vector field, ie, proportional to ξ . In terms of coordinates this means that the spatial components of X satisfy

$$\frac{\partial X^k}{\partial x^0} = 0 \quad (6.8)$$

and the time component X^0 remains unrestricted.

If $X = X^a \frac{\partial}{\partial x^a}$ is a projectible vector field, its projection is given by

$$\tilde{X}(\tilde{f}) = X(\pi^* \tilde{f}) \quad (6.9)$$

In terms of coordinates this means that one drops the time components and \tilde{X} is simply

$$\tilde{X} = X^k \frac{\partial}{\partial x^k} \quad (6.10)$$

Turning to forms, a 1-form α is projectible if $\alpha(X)$ is a projectible function provided X is a projectible vector field. That is

$$\mathcal{L}_\xi(\alpha(X)) = \mathcal{L}i_X \alpha = i_{[\xi, X]} \alpha + i_X \mathcal{L}_\xi \alpha = 0 \quad (6.11)$$

Since X is arbitrary both the terms on the right hand side must vanish separately

$$\begin{aligned} i_X \alpha &= 0 \\ \mathcal{L}_\xi \alpha &= 0 \end{aligned} \quad (6.12)$$

In terms of coordinates this takes the form

$$\begin{aligned} \alpha_0 &= 0 \\ \frac{\partial \alpha_k}{\partial x^0} &= 0 \end{aligned} \quad (6.13)$$

Now that we have shown how to project functions, vector fields and 1-forms it is easy to generalize the results to tensors.

In analogy with vector fields contravariant tensors are projectible if their Lie derivatives with respect to ξ have only time components. That is, the projection of

$$F = F^{ab} \frac{\partial}{\partial x^a} \otimes \frac{\partial}{\partial x^b} \quad (6.14)$$

is

$$\tilde{F} = F^{kl} \frac{\partial}{\partial x^k} \otimes \frac{\partial}{\partial x^l} \quad (6.15)$$

Next, in analogy with 1-forms covariant tensors are projectible if their Lie derivative vanishes and the tensors have no time components. The projection of a 2-form $\beta = \beta_{ab}dx^a \otimes dx^b$ is

$$\tilde{\beta} = \beta_{kl}dx^k \otimes dx^l \quad (6.16)$$

The above discussion was centred on the configuration space. We now consider the phase space Γ . Since \mathcal{C} is four dimensional, Γ is an eight dimensional manifold.

Let ξ be a vector field on \mathcal{C} . The quantity

$$\xi = \xi^a p_a \quad (6.17)$$

is then a function on Γ . Let \mathcal{M} be the submanifold of Γ defined by $\xi = \text{const} = q$ on \mathcal{M} . Then the 2-form ω_Γ on Γ can be pulled back to \mathcal{M} by means of the inclusion mapping

$$i : \mathcal{M} \hookrightarrow \Gamma \quad (6.18)$$

to give the 2-form

$$\omega = i^* \omega_\Gamma \quad (6.19)$$

Because ξ is constant on \mathcal{M} the vector field X_ξ is tangent to \mathcal{M} and in the kernel of ω . Thus

$$i_{X_\xi} \omega = i^*(i_{X_\xi} \omega_\Gamma) = i^* d\xi = di^* \xi = dq = 0 \quad (6.20)$$

The flows of the vector field X_ξ foliates \mathcal{M} into a six dimensional space $\tilde{\Gamma}$ and there is a natural mapping

$$\pi' : \mathcal{M} \rightarrow \tilde{\Gamma} \quad (6.21)$$

ω is π' projectible since equation(6.20) is satisfied and since

$$\mathcal{L}_{X_\xi} \omega = i_{X_\xi} d\omega + di_{X_\xi} \omega = 0 \quad (6.22)$$

as ω is a closed form. The projection $\tilde{\omega}$ is given by

$$\omega = \pi'^* \tilde{\omega} \quad (6.23)$$

$\tilde{\Gamma}$ is endowed with a symplectic 2-form $\tilde{\omega}$. The Hamiltonian \mathcal{H} is also projectible since

$$X_\xi(\mathcal{H}) = \{\mathcal{H}, \xi\} = 0 \quad (6.24)$$

The reduction of Γ to $\tilde{\Gamma}$ allows us to reduce the dynamics on Γ to that on $\tilde{\Gamma}$ via the Hamiltonian

$$\tilde{\mathcal{H}} = \frac{1}{2} \frac{q^2}{g_{00}} + \frac{1}{2} g^{kl} (p_k - qA_k)(p_l - qA_l) \quad (6.25)$$

where

$$A_k = \frac{g_{0k}}{g_{00}} \quad (6.26)$$

We now connect the phase space formalism to the usual spacetime counterpart.

Consider a particle moving in the spacetime \mathcal{Q} . The phase space Γ associated with \mathcal{Q} is defined as the cotangent bundle over \mathcal{Q} , $\Gamma = T^*\mathcal{Q}$. If \mathcal{Q} has coordinates x^a , $a = 0, 1, 2, 3$, Γ has coordinates (x^a, p_a) . Γ is an eight dimensional manifold endowed with a 1-form

$$\theta_\Gamma = p_a dx^a \quad (6.27)$$

This defines the symplectic 2-form

$$\omega_\Gamma = d\theta_\Gamma = dp_a \wedge dx^a \quad (6.28)$$

which by construction, is naturally closed.

$$d\omega_\Gamma = dd\theta_\Gamma = 0 \quad (6.29)$$

It is also non-degenerate. That is, $i_X \omega_\Gamma = 0 \Rightarrow X = 0$.

The symplectic form leads to an association between functions on Γ and vector fields. If f is a function on Γ we have

$$i_{X_f} \omega_\Gamma = df \quad (6.30)$$

defines an unique vector field X_f on Γ . If f and g are two functions on Γ , the Poisson bracket is defined by

$$\{f, g\} = X_g(f) \quad (6.31)$$

where X_g is given by

$$X_g = \frac{\partial g}{\partial p_a} \frac{\partial}{\partial x^a} - \frac{\partial g}{\partial x^a} \frac{\partial}{\partial p_a} \quad (6.32)$$

The above discussion is entirely independent of the existence of a metric.

We now consider the metric tensor g_{ab} on \mathcal{Q} . The Hamiltonian is

$$\mathcal{H} = \frac{1}{2} g^{ab} p_a p_b \quad (6.33)$$

The dynamical vector field associated with it is defined by

$$X_{\mathcal{H}} \omega_\Gamma = d\mathcal{H} \quad (6.34)$$

where

$$X_{\mathcal{H}} = \frac{\partial \mathcal{H}}{\partial p_a} \frac{\partial}{\partial x^a} - \frac{\partial \mathcal{H}}{\partial x^a} \frac{\partial}{\partial p_a} \quad (6.35)$$

This implies that if τ is an affine parameter we have the Hamilton equations

$$\begin{aligned} \frac{dx^a}{d\tau} &= \frac{\partial \mathcal{H}}{\partial p_a} = \{x^a, \mathcal{H}\} \\ \frac{dp_a}{d\tau} &= -\frac{\partial \mathcal{H}}{\partial x^a} = \{p_a, \mathcal{H}\} \end{aligned} \quad (6.36)$$

The above equations are equivalent to the geodesic equation

$$u^b u_{a;b} = 0 \quad (6.37)$$

with $u^a = \frac{dx^a}{d\tau}$. The connection between spacetime isometries and the phase space counterparts is as follows.

Let the metric admit an isometry. That is, there exists a Killing vector field ξ^a on \mathcal{Q} and the Killing equations are satisfied

$$\mathcal{L}_\xi g_{ab} = \xi_{(a;b)} = 0 \quad (6.38)$$

Or equivalently

$$\mathcal{L}_\xi g^{ab} = g^{ab,c} \xi^c - g^{cb} \xi^a{}_c - g^{ac} \xi^b{}_c \quad (6.39)$$

ξ is the infinitesimal generator of a point transformation of the system. In phase space this transformation is equivalent to a canonical transformation generated by the function $f = \xi^a p_a$ given by

$$\begin{aligned} \delta x^a &= \epsilon \{x^a, f\} = \epsilon \xi^a \\ \delta p_a &= \epsilon \{p_a, f\} = -\epsilon \xi^b{}_{,a} p_b \end{aligned} \quad (6.40)$$

As an example, let ξ be the timelike Killing vector in flat spacetime. Then the quantity $E = \xi^a p_a$ is the energy of the particle. E is a constant of the motion since from equation(6.39)

$$\frac{dE}{d\tau} = \{E, \mathcal{H}\} = -\frac{1}{2} (g^{ab,c} \xi^c - g^{cb} \xi^a{}_c - g^{ac} \xi^b{}_c) p_a p_b = 0 \quad (6.41)$$

Thus, an isometry of the spacetime implies a constant of the motion which is linear in the four-momentum p_a . ξ is the physical quantity conjugate to the cyclic coordinate singled out by the isometry. We shall find that this point is significant in that it implies that non-linear, in particular, quadratic constants of motion do not correspond to Killing vector fields. Thus, to provide a frame-work to incorporate such non-linear constants of motion we need a generalization of Killing vectors to Killing tensors. In Chapter 5, Section 5.3 we introduced the Killing tensor K^{ab} . The analogue of the Lie derivative of the metric with respect to a Killing vector may be written as

$$[K, g]_{SN}^{abc} = 2K^{d(a} g_{,d}^{bc)} - 2g^{d(a} K_{,d}^{bc)} = 0 \quad (6.42)$$

We now consider the phase space view.

If a spacetime admits a Killing tensor, there exists a quadratic constant of motion $K = K^{ab} p_a p_b$ which satisfies

$$\frac{dK}{d\tau} = \{K, \mathcal{H}\} = -\frac{1}{2} ([K, g]_{SN}^{abc}) p_a p_b p_c = 0 \quad (6.43)$$

The defined in equation(6.42) is known as the Schouten-Nijenhuis bracket. It is a generalization of the Lie bracket to symmetric tensor fields of rank greater than one. The Schouten-Nijenhuis bracket has the following properties.

1. It coincides with the Lie derivative if one of its arguments is a vector field and with the Lie bracket if both are vector fields.
2. Ordinary derivatives in equation(6.42) may be replaced by covariant derivatives without affecting the expression.
3. It is antisymmetric in its arguments and the Jacobi identity is satisfied.

In the spacetime view therefore, one needs to use with the Schouten-Nijenhuis bracket while dealing with the Killing tensor. The phase space view allows us to avoid this. In phase space one has to deal only with the Poisson bracket of functions. Instead of dealing directly with the Killing tensor, for example, one deals with the function $K = K^{ab}p_a p_b$.

With this we have not only discussed the frame-work on which the discussion in this chapter will be based but also given some motivation to prefer the phase space approach over the conventional spacetime approach. We now go on to relate the properties of the geodesics to the classification of the spacetime via the Killing and the Killing-Yano tensors.

6.3 Relation Between the Killing and the Killing-Yano Tensors

Following on the construction of the Killing-Yano tensor, it was pointed out by Floyd that the Killing tensor may be expressed in terms of the Killing-Yano tensor as

$$K^{ab} = F^{ac}F_c^b \quad (6.44)$$

The Killing-Yano tensor may therefore be regarded as a 'square root' of the Killing tensor.

It is pertinent to relate the Killing-Yano tensor to the Carter constant. Contracting F_{ab} with a four-momentum p_a we have

$$J^b = F^{ab}p_a \quad (6.45)$$

This is parallelly propagated along geodesics

$$J^a_{;b}u^b = 0 \quad (6.46)$$

And since the Carter constant is expressed through the Killing tensor we may substitute the expression for the Killing tensor in terms of the Killing-Yano tensor to obtain

$$K^{ab}p_a p_b = F^{ac}F_c^b = -J^a J_a \quad (6.47)$$

Thus one sees that it may be possible to relate J^a to the particle angular momentum.

We now focus on the Killing and the Killing-Yano tensors corresponding to the VEK spacetime and constructed in Sections 5.3 and 5.7.

First we elaborate in more detail the relation between the metric, the Killing and the Killing-Yano tensors.

Since F^{ab} may be considered as a ‘square root’ of K^{ab} and since the tetrad coefficients e_A^a may be considered as a square root of the metric tensor, it is interesting to express the Killing tensor as

$$K^{ab} = \eta^{AB} k_A^a k_B^b \quad (6.48)$$

where the k_A^a may be considered as the tetrad coefficients for the Killing tensor. Now expressing the Killing tensor in terms of the Killing-Yano tensor we have

$$K^{ab} = -g_{cd} F^{ca} F^{db} = \eta^{AB} e_{cA} e_{dB} F^{ca} F^{db} \quad (6.49)$$

Comparing equations(6.48) and (6.49) we have

$$k_A^a k_B^b = -(e_{cA} F^{ca})(e_{dB} F^{db}) \quad (6.50)$$

From this we may express the tetrad coefficients of the Killing tensor in terms of the tetrad coefficients of the metric tensor and the Killing-Yano tensor as

$$k_A^a = -ie_{cA} F^{ac} \quad (6.51)$$

where the i has been included to take care of the negative sign in equation(6.50) We may also write the relations between the tetrad coefficients and the other quantities in matrix form

$$\begin{aligned} g &= e^T e \\ K &= k^T k \\ k &= ieF \\ F &= -ie^{-1} k \end{aligned} \quad (6.52)$$

The last equation in the above obtained by inverting the third shows that we may interpret the Killing-Yano tensor, in turn, as apart from the imaginary unit, the product of the ‘square roots’ of the metric and the Killing tensors.

We exhibit here the tetrad coefficients for the VEK spacetime since knowing these is equivalent to knowing the Killing and the metric tensors. We have

$$e_a^A = \begin{pmatrix} \frac{\sqrt{\Delta}}{\bar{\rho}} & 0 & 0 & \frac{-a \sin^2 \theta}{\bar{\rho}} \\ 0 & \frac{\bar{\rho}}{\sqrt{\Delta}} & 0 & 0 \\ 0 & 0 & \frac{\bar{\rho}}{\zeta} & 0 \\ 0 & 0 & 0 & \frac{(\bar{r}^2 + a^2) \sin \theta}{\bar{\rho}} \end{pmatrix} \quad (6.53)$$

And

$$k_a^A = \begin{pmatrix} 0 & \frac{-ia \cos \theta \bar{\rho}}{\sqrt{\Delta}} & 0 & 0 \\ \frac{-a \cos \theta \sqrt{\Delta}}{\bar{\rho}} & 0 & 0 & \frac{ia^2 \cos \theta \sin^2 \theta \sqrt{\Delta}}{\bar{\rho}} \\ \frac{i\bar{r}a \sin \theta}{\bar{\rho}} & 0 & 0 & \frac{-i\bar{r} \sin \theta (\bar{r}^2 + a^2)}{\bar{\rho}} \\ 0 & 0 & \frac{-i\zeta \bar{r}}{\bar{\rho}} & 0 \end{pmatrix} \quad (6.54)$$

We note also the relations

$$\begin{aligned} \det(e_a^A) &= \frac{\bar{\rho}^2 \sin \theta}{\zeta} \\ \det(k_a^A) &= \frac{a^2 \cos^2 \theta \zeta \bar{r}^2}{\bar{\rho}^2 \sin \theta} \\ \det(F^{ab}) &= \frac{a^2 \cos^2 \theta \zeta^2 \bar{r}^2}{\bar{\rho}^4 \sin^2 \theta} \end{aligned} \quad (6.55)$$

We now express the metric, the Killing and the Killing-Yano tensor in terms of the Newman-Penrose tetrad. We have

$$\begin{aligned} ds^2 &= 2(l \otimes n - m \otimes \bar{m}) \\ K &= -2(a^2 \cos^2 \theta l \otimes n + \bar{r}^2 m \otimes \bar{m}) \\ F &= -a \cos \theta l \wedge n + i\bar{r} m \wedge \bar{m} \end{aligned} \quad (6.56)$$

6.3.1 Some remarks on the Killing and the Killing-Yano tensors

It is instructive to discuss the above form of the Killing and the Killing-Yano tensors with respect to the Kerr case.

In the Kerr case there exist theorems which imply that[9].

1. A type-D vacuum solution admits a Killing tensor

$$K_{ab} = (A^2 + B^2)(l_a n_b + n_b l_a) + B^2 g_{ab} \quad (6.57)$$

with

$$A + iB = \text{const}(\Psi)^{-1/3} \quad (6.58)$$

2. If a spacetime admits a non-degenerate Killing-Yano tensor, then this tensor can be written as

$$F_{ab} = A(l_a n_b - n_a l_b) + iB(m_a \bar{m}_b - \bar{m}_a m_b) \quad (6.59)$$

From equations(6.56) we immediately verify that the above relations hold with $A = -a \cos \theta$ and $B = \bar{r}$. The Kerr counterparts are, as usual, contained as limiting cases. In view of this it would be interesting to see whether analogous theorems can be formulated in the non-vacuum, asymptotically non-flat case also. However, we shall not pursue

this point here.

We now turn to discuss the possibility of defining angular momentum-like quantities.

By construction and also from the discussion in the previous section it follows that the quantity $K = K^{ab}p_a p_b$ is a quadratic constant of the motion. In Chapter 5 we have given some motivation to expect that the Carter constant, and therefore, the Killing tensor is somehow related to the analogue of angular momentum of the particle. To this end we considered the limiting case of the Schwarzschild spacetime. In the VEK case, as in the Kerr spacetime, there are no natural definitions of analogues of the angular momentum about the x and y axes. It is still possible to see whether there exist vector fields \hat{L}_x and \hat{L}_y which are not Killing vectors but, nevertheless, have the properties of angular momentum-like operators. If such vector fields exist, then in terms of these the Killing tensor can be expressed analogous to the Schwarzschild case. As shown by Samuel and Vishveshwara, such a decomposition does not exist even in Kerr case. Their argument goes as follows.

If L_x, L_y, L_z are angular momentum operators they must possess the following properties.

1. They must satisfy the Lie bracket relations

$$[L_j, L_k] = \epsilon_{jkl} L_l \quad (6.60)$$

2. Each orbit of these vector fields should form a two dimensional submanifold of Q .

If we define S as the three dimensional submanifold of Q generated by the vector fields L_x, L_y, L_z and ξ , the normal to S would be orthogonal to these four vector fields. If K^{ab} can be expanded in terms of the L_x, L_y, L_z it follows that the normal to S is annihilated by K^{ab} . But this is a contradiction since the Killing tensor of a stationary, axially symmetric spacetime is non-degenerate.

$$\det(K_{ab}) \neq 0 \quad (6.61)$$

As to the possibility that a non-linear combination of K^{ab} and the Killing tensors formed out of the Killing vectors may admit the decomposition the same argument shows that the normal to S is an eigenvector of K_b^a with constant eigen values. As we shall show below the eigenvalues of K_b^a are doubly degenerate.

Therefore though the Carter constant can be interpreted as the 'square' of the angular momentum in the Schwarzschild and the VES cases, such an interpretation fails in the general case.

The inability to relate the Killing tensor to the particle angular momentum motivates us to turn our attention to the Killing-Yano tensor.

6.3.2 Significance of the Killing-Yano tensor

In Chapter 5, Section 5.7 we have discussed some properties of the Killing-Yano tensor. We wish to find what grounds there are to expect that this tensor may be related to the particle angular momentum. As with the Killing tensor, it is instructive to examine the limiting Schwarzschild case of $R \rightarrow \infty$, $a = 0$ when the Killing-Yano tensor(5.162) acquires the form

$$F = r^3 \sin \theta d\theta \wedge d\phi \quad (6.62)$$

Going over to cartesian coordinates (t, x, y, z) by the transformation

$$\begin{aligned} t &= t \\ x &= r \sin \theta \cos \phi \\ y &= r \sin \theta \sin \phi \\ z &= r \cos \theta \end{aligned} \quad (6.63)$$

we find that

$$F = z dx \wedge dy + x dy \wedge dz + y dz \wedge dx \quad (6.64)$$

Or

$$F_{ab} = \epsilon_{abcd} x^c \xi^d \quad (6.65)$$

where, ξ^a is the time-like Killing vector $(1, 0, 0, 0)$.

The vector $J^b = F^{ab} p_a$ has components

$$\begin{aligned} J^0 &= 0 \\ J^x &= y p_z - z p_y \\ J^y &= z p_x - x p_z \\ J^z &= x p_y - y p_x \end{aligned} \quad (6.66)$$

And the following Poisson bracket relations expected of the angular momentum components in flat space are satisfied

$$\begin{aligned} \{J^x, J^y\} &= J^z \\ \{J^y, J^z\} &= J^x \\ \{J^z, J^x\} &= J^y \end{aligned} \quad (6.67)$$

By means of the projection formalism given in Section 6.2 we project F to space. We see that F projects to

$$\tilde{F} = z dx \wedge dy + x dy \wedge dz + y dz \wedge dx. \quad (6.68)$$

where the tilde refers to the projected quantity.

The three-dual of \tilde{F} has the components

$$\begin{aligned} \mathcal{G}_i &= \frac{1}{2} \epsilon_{ijk} \tilde{F}^{jk} \\ &= (x, y, z) \end{aligned} \quad (6.69)$$

This is the co-vector field normal to the spheres on which the angular operators act. Thus we see that the hyper-surfaces orthogonal to the dual of the spatial projection of the Killing-Yano tensor are the orbits of the rotation group. We note that the quantity

$$Tr(K) = g_{ab}K^{ab} \quad (6.70)$$

$$= -F^{ab}F_{ab} \quad (6.71)$$

$$= -2(x^2 + y^2 + z^2) \quad (6.72)$$

is constant on the spheres defined by the spherical symmetry. The angular momentum components can also be defined in terms of \tilde{F} as

$$L^i = \tilde{F}^{ji}p_j \quad (6.73)$$

These coincide with the J 's defined above.

The analysis of the above limiting case reveals, therefore, that if we wish to relate the Killing-Yano tensor to angular momentum-like quantities, the following steps are necessary.

1. Make a transformation that brings the metric to a form analogous to a flat metric. We generalize this to our requirement to mean that the metric be expressed as a sum of the background metric plus another term.
2. Going over to cartesian-like coordinates. The above step should be performed before this is made possible.
3. Project the Killing-Yano tensor onto space following the formalism of Section 6.2.
4. Find its three dimensional dual $\mathcal{G} = \mathcal{G}_i dx^i$ and check whether it is hypersurface orthogonal ie, $\mathcal{G} \wedge d\mathcal{G} = 0$.
5. Find the surfaces to which \mathcal{G} is orthogonal.

The first two steps consist in making a suitable transformation for the metric to facilitate the use of cartesian-like coordinates. This is accomplished by a generalized Kerr-Schild transformation.

In the Kerr case it is well known that casting the metric in a Kerr-Schild form enables one to write the metric as a combination of the flat and a term composed of the null tetrad form l . Since the Killing-Yano tensor is independent of the 'mass' term M it naturally remains unaffected by the absence of the source and therefore refers rather to the background spacetime. Thus, expressing F in terms of Kerr-Schild coordinates should bring it to a form analogous to that in the Schwarzschild case. That this is indeed the case is borne out by the work of Samuel and Vishveshwara[33], and Faridi[34] as already mentioned. It remains for us to see whether the Killing-Yano tensor of the VEK spacetime may also be expressed in terms of coordinates analogous to the Kerr-Schild coordinates. In our investigations

on the VES spacetime we have seen that the VES metric may be cast in a generalized Kerr-Schild form. We have introduced a ‘background black hole decomposition’ to exploit this feature and employ it to the study of conserved quantities. We do a similar analysis in the present case and show that such a decomposition gives much insight into the nature of the quantities associated with the VEK spacetime.

6.4 The Background-Black Hole Decomposition

We recall that the background-black hole decomposition allows us to exploit features associated with a generalized Kerr-Schild form of the metric. We first develop this decomposition for the VEK case and then consider the significance of casting the metric in a generalized Kerr-Schild form.

Recalling the procedure followed in Chapter 2 we first decompose the Newman-Penrose tetrad forms into background and black hole terms. In terms of the generalized Boyer-Lindquist coordinates it is not possible to achieve this. Therefore we need to go over to a transformation to new coordinates $(u, r, \theta, \tilde{\phi})$ by

$$\begin{aligned} du &= dt - \frac{\bar{r}^2 + a^2}{\Delta} dr \\ d\phi &= d\tilde{\phi} - \frac{a}{\Delta} dr \end{aligned} \quad (6.74)$$

In terms of these coordinates the metric assumes the form

$$ds^2 = \left(1 - \frac{2Mr}{\bar{\rho}^2}\right) du^2 + 2dudr - \frac{\bar{\rho}^2}{\zeta^2} d\theta^2 - \frac{\bar{\Sigma}^2 \sin^2 \theta}{\bar{\rho}^2} d\tilde{\phi}^2 + \frac{4Mra \sin^2 \theta}{\bar{\rho}^2} dud\tilde{\phi} - 2a \sin^2 \theta dr d\tilde{\phi} \quad (6.75)$$

$$g_{ab} = g_{ab}^E + h l_a^E l_b^E \quad (6.76)$$

where

$$h = -\frac{2Mr}{\bar{\rho}^2} \quad (6.77)$$

In terms of these coordinates the Newman-Penrose tetrad forms become

$$\begin{aligned} l &= l_a dx^a = du - a \sin^2 \theta d\tilde{\phi} \\ n &= n_a dx^a = \frac{\bar{r}^2 + a^2}{2\bar{\rho}^2} l + dr - \frac{Mr}{\bar{\rho}^2} l \\ m &= m_a dx^a = \frac{i \sin \theta}{\sqrt{2\bar{\rho}_1}} (adu - (\bar{r}^2 + a^2) d\tilde{\phi}) - \frac{\bar{\rho}^2}{\sqrt{2\bar{r}_1}} d\theta \\ \bar{m} &= \frac{-i \sin \theta}{\sqrt{2\bar{\rho}_1^*}} (adu - (\bar{r}^2 + a^2) d\tilde{\phi}) - \frac{\bar{\rho}^2}{\sqrt{2\bar{\rho}_1^*}} d\theta \end{aligned} \quad (6.78)$$

and the following relations are useful.

$$\begin{aligned} l \wedge n &= (du - a \sin^2 \theta d\tilde{\phi}) \wedge dr \\ m \wedge \bar{m} &= -a \sin \theta (adu - (\tilde{r}^2 + a^2)d\phi) \wedge d\theta \end{aligned} \quad (6.79)$$

We now express all the tetrad forms in terms of the corresponding Einstein background quantities.

$$\begin{aligned} l &= l_E \\ n &= n_E - \frac{Mr}{\tilde{\rho}^2} l_E \\ m &= m_E \\ l \otimes n &= l_E \otimes n_E - \frac{Mr}{\tilde{\rho}^2} l_E \otimes l_E \\ m \otimes \bar{m} &= m_E \otimes \bar{m}_E \end{aligned} \quad (6.80)$$

the subscript E referring to the Einstein universe.

In terms of the decomposed tetrad forms the metric becomes

$$ds^2 = 2(l \otimes l - m \otimes \bar{m}) = 2(l_E \otimes n_E - m_E \otimes \bar{m}_E) - \frac{2Mr}{\tilde{\rho}^2} l_E \otimes l_E \quad (6.81)$$

This may be written in the form

$$\begin{aligned} ds^2 &= ds_E^2 - \frac{2Mr}{\tilde{\rho}^2} l_E \otimes l_E \\ g_{ab} &= g_{ab}^E - \frac{2Mr}{\tilde{\rho}^2} l_a^E l_b^E \end{aligned} \quad (6.82)$$

Since l_a^E is null its index can equally be raised with g^{ab} or g_E^{ab}

$$g^{ab} l_b = g_E^{ab} l_b \quad (6.83)$$

The present form of the quantities facilitate the introduction of cartesian-like coordinates by another transformation

$$\begin{aligned} t &= u - r \\ x &= (R \sin(r/R) \cos \tilde{\phi} + a \cos(r/R) \sin \tilde{\phi}) \sin \theta \\ y &= (R \sin(r/R) \sin \tilde{\phi} - a \cos(r/R) \cos \tilde{\phi}) \sin \theta \\ z &= R \sin(r/R) \cos \theta \end{aligned} \quad (6.84)$$

And the full metric may be expressed as

$$ds^2 = dt^2 - d\bar{x}^2 - d\bar{y}^2 - d\bar{z}^2 - \frac{(\bar{x}d\bar{x} + \bar{y}d\bar{y} + \bar{z}d\bar{z})^2}{(R^2 - \bar{x}^2 - \bar{y}^2 - \bar{z}^2)} + hl_E \otimes l_E \quad (6.85)$$

The Newman-Penrose tetrad form l assumes the form

$$l = dt - \frac{\bar{r}\bar{x} - a\bar{y}}{\bar{r}^2 + a^2} dx + \frac{\bar{r}\bar{y} + a\bar{x}}{\bar{r}^2 + a^2} dy + \frac{\bar{z}}{\bar{r}} \quad (6.86)$$

The metric given by equation(6.82) is of a generalized Kerr-Schild form. As $R \rightarrow \infty$ the metric reduces to the Kerr metric in a Kerr-Schild form

$$g_{ab} = \eta_{ab} + h_F l_a^F l_b^F \quad (6.87)$$

where F refers to the flat background.

The fact that the VEK metric is expressible in a generalized Kerr-Schild form is significant. It is known that a metric which is expressible in a Kerr-Schild form are algebraically special[9] of type-II. Indeed, from the Kerr-Schild form(6.87) it can be shown[44] that

$$R_{bcd}^a l^b l^d = -\ddot{h} l^a l_c \quad (6.88)$$

This leads to the condition

$$l_{[e} R_{a]bcd} l^b l^d = 0 \quad (6.89)$$

In the case of a vacuum spacetime the Riemann tensor coincides with the Weyl tensor and therefore the above condition becomes

$$l_{[e} C_{a]bcd} l^b l^d = 0 \quad (6.90)$$

which implies that the spacetime represented by a metric which can be expressed in a Kerr-Schild form is of type-II. The tetrad form l corresponds to a repeated null direction of the Weyl tensor. The Goldberg-Sachs theorem which is applicable in the vacuum case then implies that l is also shear-free.

When the metric is of a generalized Kerr-Schild form also it is known that the corresponding spacetime is of type-II. However, due to the absence of a theorem like that of Goldberg and Sachs, one cannot conclude that l is shear-free. But as we have shown explicitly, the VEK metric is indeed type-D.

We now proceed to decompose the various geometrical quantities introduced above.

First, the Hamiltonian takes the form

$$\mathcal{H} = \frac{1}{2} g^{ab} p_a p_b = \frac{1}{2} g_E^{ab} p_a p_b - h(l \cdot p)^2 \quad (6.91)$$

Thus the four-momentum is given by

$$p_a = g_{ab} \dot{x}^b = g_{ab}^E \dot{x}^b - h(l \cdot p) l_a \quad (6.92)$$

This may be written in the form

$$p_a = p_a^E - h(l \cdot p)l_a \quad (6.93)$$

where p_a^E is the four-momentum of a particle corresponding to the metric of the Einstein universe. We note that $l^E \cdot p = l \cdot p^E$ since l is null.

The energy and the azimuthal angular momentum are therefore given by

$$\begin{aligned} E &= E_E - h(l \cdot p) \\ p_\phi &= p_\phi^E + a \sin^2 \theta h(l \cdot p) \end{aligned} \quad (6.94)$$

where we have substituted the expressions for the components of l .

In terms of the cartesian-like coordinates we have

$$\begin{aligned} E &= E_E - h(l \cdot p) \\ p_z &= p_z^E - \frac{zh}{\bar{r}}(l \cdot p) \end{aligned} \quad (6.95)$$

Next, the Killing tensor may be decomposed as

$$\begin{aligned} K &= -2(a^2 \cos^2 \theta l \otimes n + \bar{r}^2 m \otimes \bar{m}) \\ &= -2(a^2 \cos^2 \theta l_E \otimes n_E + \bar{r}^2 m_E \otimes \bar{m}_E) + \frac{2M\bar{r}}{\bar{\rho}^2} a^2 \cos^2 \theta l_E \otimes l_E \end{aligned} \quad (6.96)$$

This may be written in the form

$$\begin{aligned} K &= K_E + \frac{2M\bar{r}}{\bar{\rho}^2} a^2 \cos^2 \theta l_E \otimes l_E \\ K_{ab} &= K_{ab}^E - a^2 \cos^2 \theta h l_a^E l_b^E \end{aligned} \quad (6.97)$$

In this form the eigenvalues of the Killing tensor are easy to find. We see that l_a^E is an eigenvector of K_E^{ab}

$$K^{ab} l_a^E = K_E^{ab} l_b^E = a^2 \cos^2 \theta l_E^b \quad (6.98)$$

The eigenvalues are given by

$$\begin{aligned} K^{ab} l_a^E n_b^E &= K_E^{ab} l_b^E = a^2 \cos^2 \theta \\ K^{ab} m_a^E \bar{m}_b^E &= K_E^{ab} m_b^E = \bar{r}^2 \end{aligned} \quad (6.99)$$

The decomposed form of the Killing-Yano tensor is

$$F = F_E \quad (6.100)$$

Explicitly, the expression is the same as that obtained in Chapter 5 where if we recall, it was calculated directly in terms of generalized Kerr-Schild coordinates

$$F_{ab} = \begin{pmatrix} 0 & -a \cos \theta & \frac{a\bar{r} \sin \theta}{\zeta} & 0 \\ a \cos \theta & 0 & 0 & -\frac{a^2 \sin^2 \theta \cos \theta}{\bar{r}(\bar{r}^2 + a^2)} \\ -\frac{a\bar{r} \sin \theta}{\zeta} & 0 & 0 & \frac{\bar{r}(\bar{r}^2 + a^2) \sin \theta}{\zeta} \\ 0 & a^2 \sin^2 \theta \cos \theta & -\frac{\bar{r}(\bar{r}^2 + a^2) \sin \theta}{\zeta} & 0 \end{pmatrix} \quad (6.101)$$

Or

$$\begin{aligned} F &= \frac{1}{2} F_{ab} dx^a \wedge dx^b \\ &= -a \cos \theta (du - a \sin^2 \theta d\phi) \wedge dr + \frac{\bar{r}}{\zeta} \sin \theta (adt - (\bar{r}^2 + a^2) d\phi) \wedge d\theta \end{aligned} \quad (6.102)$$

$$F^{ab} = \begin{pmatrix} 0 & \frac{a \cos \theta (\bar{r}^2 + a^2)}{\bar{\rho}} & \frac{-a\bar{r} \sin \theta \zeta}{\bar{\rho}^2} & 0 \\ -\frac{a \cos \theta (\bar{r}^2 + a^2)}{\bar{\rho}} & 0 & 0 & \frac{-a^2 \cos \theta}{\bar{\rho}^2} \\ \frac{a\bar{r} \sin \theta \zeta}{\bar{\rho}^2} & 0 & 0 & \frac{\zeta \bar{r}}{\bar{\rho}^2 \sin \theta} \\ 0 & \frac{a^2 \cos \theta}{\bar{\rho}^2} & \frac{-\zeta \bar{r}}{\bar{\rho}^2 \sin \theta} & 0 \end{pmatrix} \quad (6.103)$$

In terms of the Newman-Penrose tetrad F takes the simple form

$$\begin{aligned} F &= -a \cos \theta l \wedge l + i\bar{r} m \wedge \bar{m} \\ F_{ab} &= -a \cos \theta (l_a n_b - l_b n_a) + i\bar{r} (m_a \bar{m}_b - m_b \bar{m}_a) \end{aligned} \quad (6.104)$$

This immediately allows us to find the eigenvector and the eigenvalues of F . We find that l is an eigenvector of F

$$F_{ab} l^a = -a \cos \theta l_b \quad (6.105)$$

and the eigenvalues are given by

$$\begin{aligned} F_{ab} l^a n^b &= a \cos \theta \\ F_{ab} m^a \bar{m}^b &= -i\bar{r} \end{aligned} \quad (6.106)$$

6.5 Particle Angular Momentum

Before we proceed to cast this into a cartesian-like form we need to perform the steps outlined in Section 5. To this end we project the Killing-Yano tensor onto space

$$\tilde{F}^{ab} = \begin{pmatrix} 0 & 0 & \frac{-a^2 \cos \theta}{\bar{\rho}^2} \\ 0 & 0 & \frac{\zeta \bar{r}}{\bar{\rho}^2 \sin \theta} \\ \frac{a^2 \cos \theta}{\bar{\rho}^2} & \frac{-\zeta \bar{r}}{\bar{\rho}^2 \sin \theta} & 0 \end{pmatrix} \quad (6.107)$$

Its three dimensional dual is given by

$$\mathcal{G}_a = \frac{\sqrt{|g|}}{2} \epsilon_{abc} \tilde{F}^{bc} \quad (6.108)$$

Evaluating the components we find

$$\begin{aligned}\mathcal{G}_1 &= \frac{\sqrt{|g|}\bar{r}}{\bar{\rho}^2 \sin \theta} \\ \mathcal{G}_2 &= \frac{\sqrt{|g|}a^2 \cos \theta}{\bar{\rho}^2}\end{aligned}\quad (6.109)$$

whence

$$\mathcal{G} = \mathcal{G}_a dx^a = \frac{\bar{\Sigma}}{\sqrt{\Delta}\bar{\rho}\zeta}(\bar{r}dr + a^2 \cos \theta \sin \theta d\theta) \quad (6.110)$$

This expression simplifies to

$$\mathcal{G} = \frac{\bar{r}dr + a^2 \cos \theta \sin \theta d\theta}{\sqrt{1 - \frac{2Mr}{\bar{\rho}^2}}} \quad (6.111)$$

It is a straight-forward verification that

$$\mathcal{G} \wedge d\mathcal{G} = 0 \quad (6.112)$$

Thus \mathcal{G} is hypersurface orthogonal. We therefore write

$$\mathcal{G} = gdf \quad (6.113)$$

where $g = \sqrt{\xi \cdot \xi}$ and

$$f = \frac{1}{2}(\bar{r}^2 + a^2 \sin^2 \theta) \quad (6.114)$$

Therefore the surfaces orthogonal to \mathcal{G} are given by

$$\bar{r}^2 + a^2 \sin^2 \theta = \text{constant} \quad (6.115)$$

In accordance with the steps(5) we identify these as the surfaces on which the angular momentum operators act. To find these operators we need to make a transformation to the cartesian-like coordinates defined by equations(6.84) under which the Killing-Yano tensor acquires the form

$$F_{ab} = \begin{pmatrix} 0 & 0 & 0 & a \\ 0 & 0 & \bar{z} & -\bar{y} \\ 0 & -\bar{z} & 0 & \bar{x} \\ -a & \bar{y} & -\bar{x} & 0 \end{pmatrix} \quad (6.116)$$

Or

$$F = a dt \wedge dz + \bar{z} dx \wedge dy + \bar{x} dy \wedge dz + \bar{y} dz \wedge dx \quad (6.117)$$

We see that this form of the Killing-Yano tensor is similar, apart from the time component containing a , to that in the limiting case of the Schwarzschild spacetime given by equation(6.68).

We note that the dual of F is given by

$$\mathcal{F} = \begin{pmatrix} 0 & \bar{x} & \bar{y} & \bar{z} \\ -\bar{x} & 0 & a & 0 \\ -\bar{y} & -a & 0 & 0 \\ -\bar{z} & 0 & 0 & 0 \end{pmatrix} \quad (6.118)$$

We find that

$$d\mathcal{F} = 0 \quad (6.119)$$

Therefore \mathcal{F} may be written as $\mathcal{F} = dA$ where A may be thought of as a vector potential. For \mathcal{F} we find that

$$A = -\frac{1}{2}(\bar{x}^2 + \bar{y}^2 + \bar{z}^2)dt - \frac{1}{2}a\bar{y}dx + \frac{1}{2}a\bar{x}dy \quad (6.120)$$

We now proceed to see whether the analogy with the Schwarzschild case may be built up. We project to space to obtain

$$\tilde{F}_{ab} = \begin{pmatrix} 0 & 0 & 0 & 0 \\ 0 & 0 & \bar{z} & -\bar{y} \\ 0 & -\bar{z} & 0 & \bar{x} \\ 0 & \bar{y} & -\bar{x} & 0 \end{pmatrix} \quad (6.121)$$

Or

$$\tilde{F} = \bar{z}dx \wedge dy + \bar{x}dy \wedge dz + \bar{y}dz \wedge dx \quad (6.122)$$

This has a similar form as the Schwarzschild counterpart.

Its three dimensional dual is

$$\mathcal{G} = \bar{x}dx + \bar{y}dy + \bar{z}dz \quad (6.123)$$

Thus we now define the angular momentum on space via

$$\tilde{L}^i = \tilde{F}^{ji}p_j \quad (6.124)$$

Its three components are

$$\begin{aligned} \tilde{L}_x &= x_i \tilde{F}^{ji} p_j \\ \tilde{L}_y &= y_i \tilde{F}^{ji} p_j \\ \tilde{L}_z &= z_i \tilde{F}^{ji} p_j \end{aligned} \quad (6.125)$$

These components define vector fields on space given by

$$\begin{aligned} \tilde{L}_x &= x_i \tilde{F}^{ji} \frac{\partial}{\partial x^j} \\ \tilde{L}_y &= y_i \tilde{F}^{ji} \frac{\partial}{\partial x^j} \\ \tilde{L}_z &= z_i \tilde{F}^{ji} \frac{\partial}{\partial x^j} \end{aligned} \quad (6.126)$$

We lift these vector fields to spacetime. Since the time component is left unspecified the lifts are not unique. We fix the time component by imposing that the lifts be orthogonal to the timelike Killing vector ξ with respect to the flat metric

$$L^a \eta_{ab} \xi^b = 0 \quad (6.127)$$

This means that the time components of these vector fields are zero. Now the angular momentum components thus defined by this fixing

$$\begin{aligned} L_x &= yp_z - zp_y \\ L_y &= zp_x - xp_z \\ L_z &= xp_y - yp_x \end{aligned} \quad (6.128)$$

satisfy the Poisson bracket relations

$$\begin{aligned} \{L_x, L_y\} &= L_z \\ \{L_y, L_z\} &= L_x \\ \{L_z, L_x\} &= L_y \end{aligned} \quad (6.129)$$

These definitions of angular momentum lead to physically meaningful results as we shall show below

We study the dynamical evolution of the angular momentum vector to first order in a and to second order in $1/R$. To do this we need to find the equations of motion for L_x, L_y, L_z given by

$$\begin{aligned} \dot{L}_x &= \{L_x, \mathcal{H}\} \\ \dot{L}_y &= \{L_y, \mathcal{H}\} \\ \dot{L}_z &= \{L_z, \mathcal{H}\} \end{aligned} \quad (6.130)$$

Using the expression for the Hamiltonian given in equation(6.91) we find

$$\begin{aligned} \dot{L}_z &= 0 \\ \dot{L}_x &= \frac{h l_a p^a a}{R^2 \sin^2(r/R)} L_y, \\ \dot{L}_y &= -\frac{h l_a p^a a}{R^2 \sin^2(r/R)} L_x \end{aligned}$$

where the dot denotes differentiation with respect to the proper time parameter ' τ '.

This means that the angular momentum vector of the particle precesses about that of the VEK black hole, preserving its magnitude. In higher orders there appears to be no such straight-forward interpretation. Moreover it is possible that then the magnitude of the vector too changes with ' τ ' as is true in the Kerr case.

In Chapter 4, we have seen that the gyroscopic precession in the VEK spacetime departs significantly from that in the the Kerr case. Here we have an analogous precession of the angular momentum-like vector which is a dynamical quantity.

6.6 Concluding Remarks

In this chapter we have carried out a detailed investigation of the particle angular momentum structure in the VEK spacetime. We have been motivated by the need to understand the nature of quantities that go into defining the angular momentum vector in the spacetime of a stationary, axisymmetric black hole when the spacetime is surrounded by matter distribution and the background is no longer asymptotically flat.

We have investigated the relation between the Killing and the Killing-Yano tensors. The Killing tensor has been obtained as the ‘square’ of the Killing-Yano tensor. Both these tensors have been expressed through the Newman-Penrose tetrads to further clarify their structure. We have shown that these tensors contain the Kerr counterparts as limiting cases. By constructing a tetrad for the Killing tensor we have further exhibited the relations between the metric, the Killing and the Killing-Yano tensors. The eigenvalues of these tensors have been calculated.

We have introduced the background-black hole decomposition for the VEK spacetime and discussed the generalized Kerr-Schild (and the Kerr-Schild as a special case) transformation and its significance. By employing this decomposition we have expressed the Newman-Penrose tetrad in terms of background and black hole terms. Further, we have split the Hamiltonian, the four-momentum, and the Killing tensor into background and black hole terms. We have shown that the Killing-Yano tensor has only a background term.

Focusing on the Killing-Yano tensor we have employed the phase space formalism to project it to the three dimensional space. By means of the projected tensor we have defined quantities analogous to the components of particle angular momentum. These components satisfy the Poisson bracket relations expected of them. We have shown that to first order in the angular momentum parameter and to second order in the inverse of the background parameter, the angular momentum vector precesses about the rotational axis preserving its magnitude.

Thus we see that in the VEK spacetime it is possible to define an analogue of the particle angular momentum associated with the Killing-Yano tensor. In spite of the apparent similarity to the Kerr case, there is here a considerable modification in that the background parameter now figures in a significant manner. Lastly, all of the above results reduce to

the Kerr counterparts as the background parameter tends to infinity. Thus, the entire discussion may be taken over, over by specialization to the Kerr case.

**BLACK HOLES
IN
COSMOLOGICAL BACKGROUNDS**

*A thesis
submitted for the degree of
Doctor of Philosophy
in the Faculty of Science
University of Calicut, India*

B. S. Ramachandra

**Indian Institute of Astrophysics
Bangalore, India**

March 2003

Chapter 7

Conclusion

In the present thesis we have investigated two prototypes of black holes in non-flat backgrounds. We have been motivated by the need to understand the natures of black holes when the well-known features of asymptotic flatness and time independence are given up. Our approach has been to study specific examples in order to gain insight into the nature of black holes wherein one or both the above features are absent. In this thesis, however, we retain time independence. We have taken as specific examples the family of solutions given by Vaidya that represent black holes in cosmological backgrounds. One of this represents the Kerr black hole and the other represents the Schwarzschild black hole, in the background of the Einstein universe. We may, however, note that these spacetimes are in reality non-vacuum solutions that in the limit go over to the respective black holes and the Einstein universe. These spacetimes may be viewed as those of black holes surrounded by matter distribution satisfying reasonable energy conditions. The basic purpose of this study is to compare and contrast the well known properties of the usual black holes with those in non-vacuum surroundings. We now give a brief summary of the results obtained.

7.1 Summary of Results

We have begun by investigating the Vaidya-Einstein-Schwarzschild(VES) black hole constructed by Nayak, Mac Callum and Vishveshwara. This VES spacetime is asymptotically non-flat but is time independent. The event horizon coincides with the Killing horizon. By studying this spacetime, we have shown that the introduction of the non-flat background modifies the Schwarzschild results considerably. As opposed to the Schwarzschild case, the nature of the null geodesics is drastically affected. The time-like circular geodesics behave in a radically different manner as compared with their Schwarzschild counterparts. Regarding the classical tests- the gravitational redshift is modified from that in the Schwarzschild spacetime and the perihelion precession and light bending undergo an increase.

We have next focused on the Vaidya-Einstein-Kerr(VEK) black hole. The VEK event horizon is a Killing horizon as in the case of the Kerr spacetime. By concentrating on the

geometry of the event horizon, we have shown that the background gives rise to significant modifications in the geometrical and physical quantities associated with the black hole. The event horizon shrinks from its limiting Kerr magnitude as the background influence increases and the stationary limit surface gets more distorted. This manifests itself as an enlargement of the ergosphere. The distortion of the horizon can be ascertained by computing its equatorial and polar circumferences and studying the variation of the oblateness parameter. The oblateness parameter is given by the difference of the equatorial and polar circumferences divided by the equatorial circumference. We have studied this by two different approaches. In the first instance, to compare the results with those obtained by Smarr in the Kerr case, we have varied the distortion parameter without varying the background parameter. In this formalism the equatorial circumference remains the same as that of the Kerr horizon which of course varies with the distortion parameter. Nevertheless, the polar circumference progressively decreases but more slowly than in the Kerr case. The combined effect is that the oblateness parameter increases more slowly as compared with the Kerr case. In a sense, these computations reveal the variation of the oblateness modified by the background and as compared with the Kerr horizon.

We have showed that further insight can be gained into the structure of the horizon by investigating the oblateness as an explicit function of the angular momentum parameter and the background parameter. As we have pointed out there exist both modulated and direct effects.

The modulated effect is obtained by varying the angular momentum parameter for different fixed values of the background parameter. Here we have found a totally unexpected effect. That is, whereas the equatorial circumference increases monotonically with the angular momentum parameter for all values of the background parameter, the polar circumference first decreases as the angular momentum parameter increases, starting from the Kerr value, and then increases after a critical value of the background parameter. Nevertheless, the oblateness parameter increases with the angular momentum parameter for all values of the background parameter. On the other hand the direct effect is obtained by varying the circumferences with the background parameter. Here, one sees that both the equatorial and the polar circumferences decrease as the background parameter decreases, ie as the background influence increases. However, the oblateness parameter increases as the background parameter decreases.

Another quantity that indicates the change in the geometry of the event horizon is its surface area. As was done in the case of the circumferences, we have studied two different effects of the background on the area. First the modulation of rotation by the background and second the direct effect of the background. In the first case, for large values of the background parameter the area decreases monotonically with the angular momentum parameter as in the Kerr case. Then for a critical range of values of the background parameter the area increases, attains a maximum and then, decreases. Finally for small values of the

background parameter it increases monotonically with the angular momentum parameter. This effect is also a novel one which reveals the peculiarity of the background influence. Next, we have the direct effect of the background. As the background parameter decreases thereby enhancing the background effect, the area decreases and asymptotically approaches the Kerr value as the background effect goes down.

Turning to the angular velocity of the VEK event horizon, we have shown that it goes up significantly as the background influence increases. By means of the surface gravity of the VEK horizon we have shown that the extreme VEK black hole occurs as in the Kerr case. However the equatorial tangential velocity defined in analogy with the Kerr case is no longer that of light. Motivated by this we have classified the VEK black hole into two types. We have shown that in addition to the extreme type, another type of black hole the 'limiting black hole' may be defined for which this velocity is that of light.

By investigating the intrinsic geometry as represented by the Gaussian curvature we have shown that the VEK black hole may be classified into two distinct classes. The first class consists of black holes with positive Gaussian curvature and the second consists of black holes with negative Gaussian curvature. In the Kerr case studied by Smarr, this classification is on the basis of two constant 'limiting' values of the distortion parameter. In the VEK case however, the corresponding 'limiting' values are no longer constants but depend on the angular momentum parameter and the background parameter the background parameter. The topology of the VEK event horizon is that of a 2-sphere as may be expected for any normal black hole.

From a study of the geometry we have moved on to investigate some physical effects in the VEK spacetime. By studying circular geodesics we have shown that there is a significant departure of the VEK results from the usual Kerr counterparts. This is due to the matching of the Vaidya spacetime to the Einstein universe wherein there are no circular geodesics at all. In the Kerr spacetime only one null circular geodesic exists. Corresponding to this there is one co-rotating and one counter-rotating orbit. Timelike geodesics exist all the way up to infinity. In contrast, the VEK case allows two different possibilities depending on the background parameter.

In the first case two null circular geodesics are present. There is an inner null geodesic and an outer null geodesic. Each of these have one co-rotating and one counter-rotating orbit. Timelike geodesics exist between the inner and the outer null geodesics.

In the second case only one null geodesic exists. Corresponding to this is one co and one counter-rotating orbit. There is a complete absence of timelike circular geodesics. The impact parameter also reflects this feature as we have shown in the special case of the VES spacetime.

By investigating the phenomena of gyroscopic precession in the VEK spacetime we have shown that the background affects the precession in both modulated and direct effects. The first torsion which in the Kerr case coincided with the Schwarzschild Keplerian frequency now no longer coincides with the VES generalized Keplerian frequency. It is now a function of the angular momentum parameter as well in contrast to the Kerr case. This brings about a pronounced modification of the results from the Kerr case. In particular this gives rise to a generalized version of the Schiff precession. Moreover, even in the special cases of the generalized versions of the Fokker-De Sitter precession in the VES spacetime, the background prevents the first torsion from being equivalent to the generalized Keplerian frequency. Finally, the generalized version of the Thomas precession in the Einstein universe is also considerably modified.

As mentioned in the introductory chapter, a study of the Carter constant and the Petrov classification sheds light on the connection between the properties of the geodesics and the classification of the gravitational field. Thus, starting with a discussion of Carter's discovery of the fourth constant in the Kerr case, we have shown by construction that the Carter constant exists in the VEK spacetime also. From the Carter constant we have obtained the Killing tensor and brought out its significance by considering the special case of the Schwarzschild spacetime wherein the Killing tensor becomes reducible.

Next, taking into account the fact that in the Kerr spacetime, the Killing tensor is related to the Killing-Yano tensor which, in turn, is related to the type-D nature of the spacetime, we have investigated the classification of the VEK spacetime. By employing the Newman-Penrose formalism we have calculated the spin coefficients for the VEK spacetime. We have shown that unlike the Kerr case there is a non-vanishing spin coefficient ϵ . Even though the rest of the results mirror that in the Kerr case, their expressions are considerably complicated. These spin coefficients contain as limiting cases the Kerr and the VES counterparts and of course the Schwarzschild ones also. The Bianchi identities contain non-zero Ricci terms also in addition to the Weyl scalars.

Motivated by the significance of the type-D nature of a black hole spacetime we have studied the classification of the VEK spacetime. We have demonstrated explicitly and in detail, that the VES spacetime is type-D. We have shown that the only non-vanishing Weyl scalar is Ψ_2 . Turning to the Ricci terms, the only non-zero terms are Φ_{00} , Φ_{11} , Φ_{22} and the scalar Λ . That these terms which vanish in the Schwarzschild case do not do so here shows that the spacetime is non-vacuum. In the Einstein universe also the Ricci terms are non-zero which brings out the asymptotically non-flat nature of the spacetime. The optical scalars ω and σ vanish as in the Schwarzschild case whereas the optical scalar Θ is modified because of the background.

We have discussed the 2-spinor formalism and constructed the Killing spinor for the VEK spacetime. By means of the Killing spinor we have calculated the Killing-Yano tensor and shown that in the limit of the background parameter tending to infinity this coincides with the Killing-Yano tensor of the Kerr spacetime.

With the above apparatus in hand, we have investigated the relation between the Killing and the Killing-Yano tensors. The Killing tensor has been shown to be a 'square' of the Killing-Yano tensor. Both these tensors have been expressed through the Newman-Penrose tetrads to further clarify their structure. We have shown that these tensors contain the Kerr counterparts as limiting cases. By constructing a tetrad for the Killing tensor we have further exhibited the relations between the metric, the Killing and the Killing-Yano tensors. The eigenvalues of these tensors have been calculated.

We have introduced the background-black hole decomposition and discussed the Kerr-Schild and the generalized Kerr-Schild transformations and their implications for the Kerr and the VEK cases respectively. By employing this decomposition we expressed the Newman-Penrose tetrad in terms of background and black hole terms. Further, we have split the Hamiltonian, the four-momentum, and the Killing tensor into background and black hole terms. We have shown that the Killing-Yano tensor has only a background term.

Focusing on the Killing-Yano tensor we have employed the phase space formalism to project it to space. By means of the projected tensor we have defined quantities analogous to the components of particle angular momentum. These components satisfy the Poisson bracket relations expected of them. We have shown that to first order in the angular momentum parameter and to second order in the inverse of the background parameter, the angular momentum vector precesses along the central black hole preserving its magnitude.

The above results clearly demonstrate that the effect of the background on the properties of the usual black holes are significant. We see that the results may be classified into three groups. In the first, the properties of the black holes are *retained*. Such is the case with the gravitational redshift discussed in Chapter 2 and the existence of the Carter constant and the Petrov classification of the VES spacetime discussed in Chapter 5. These prove to be similar to that in the flat case. In the second case, the properties of the black holes are considerably *modified*. This is the case with the perihelion precession, the bending of light considered in Chapter 2, the geometry of the ergosphere, the angular velocity, topology, and the nature of the spin coefficients corresponding to the VEK black hole as shown in Chapter 5. In the third case, the properties of the black holes are *radically altered*. This includes the behavior of circular geodesics and the classification of the timelike geodesics in the VES spacetime discussed in Chapter 2, circular geodesics in the VEK spacetime and the nature of gyroscopic precession discussed in Chapter 4. Thus the background has a significant impact at various levels of complexity, from minor modifications to total depar-

ture from the standard cases.

We have shown that a study of specific examples gives considerable insight into the nature of black holes which are not asymptotically flat. The effect of the background on the properties of the usual black holes is clear and patent. As a prototype the Vaidya cosmological black holes on which we have based our investigations are specific and restricted. It is not at all unlikely that the above effects may be retained or even enhanced in more realistic models.

We now proceed to discuss some significant issues that suggest themselves in course of our investigations.

7.2 Discussion

In the following, we enumerate and discuss some of the significant issues that have arisen and need to be addressed further.

1. From the above summary we have seen that the influence of the non-flat background on physical and geometrical properties of the black hole is three-fold in that they are either *retained*, *modified* or *radically altered*. It would be instructive to perform a detailed classification of physical phenomena based on these criteria. Such a study can play the role of an issue by itself.
2. In our investigations on the VEK black hole we have seen that the surface area of the horizon behaves in a *radically altered* manner in contrast to the Kerr black hole. The physical reason behind this behavior may not be obvious since the VEK black hole is surrounded by matter distribution. Moreover, it is not clear as to how the rotation of the background itself contributes to this effect. It would be interesting and instructive to study this issue in detail.
3. The angular velocity of the VEK horizon increases monotonically as the background influence increases. As in the case of the surface area, the part that the rotation of the background plays in bringing about this effect would be of considerable interest.
4. It is well known that the surface area of the black hole plays a significant role in that it serves as a point of departure for black hole thermodynamics. In the Kerr case, the variation of the mass of the black hole may be expressed in terms of the variations of the surface area and the angular momentum with constant coefficients which turn out to be essentially the surface gravity and the angular velocity of the

horizon respectively. In the VEK case, however, as borne out by our preliminary investigations(not included in the present thesis) the corresponding coefficients are not constants but functions of the mass, the angular momentum and the background parameters. Moreover, it seems to be possible to admit the variation of the background parameter as an additional contribution. This feature, together with the *radically altered* behavior of the area indicates that it is not unlikely that there may be a significant departure from the standard black hole thermodynamics. Along with these, there is associated, the physical interpretation of the area as analogous to the entropy of the black hole. In the VEK spacetime in contrast to the Kerr case, we may have to take into account a possible additional contribution to the black hole entropy from the matter surrounding the black hole. Thus, a study of black hole thermodynamics of the VEK black hole starting from an investigation of the behavior of the surface area seems to be an important and promising issue.

5. Another issue has to do with the way in which Machian ideas are associated with our investigations. In the case of the Kerr black hole, the dragging of inertial frames and related phenomena are often considered as a manifestation of the so called Mach principle. This is because of the effect of the black hole on its surrounding. The vacuum, flat background itself obviously has no direct influence on the physical phenomena associated with the black hole. In the VEK case, on the other hand, there is clearly an effect of the background on the physical phenomena as well as on the black hole. This is a novel feature arising out of the non-flat background. In this respect, the background-black hole decomposition that we have introduced may be of help in separating out the effects of the black hole from Machian effects due to the background representing the matter content of the rest of the universe.
6. The question of stability that we alluded to in Chapter 1 comes up again here in the form of the stability of the VEK spacetime. As is well-known, the usual black hole spacetimes are stable whereas the Einstein universe is not. It is not clear as to the nature of the stability of a composite spacetime subsuming both the black hole and the Einstein universe. The stability or otherwise of a composite spacetime that yields either the black hole or the Einstein universe as limiting cases is an open question.
7. Lastly, apart from the VES and the VEK black holes which have the Einstein universe as background, one would like to have more realistic models. There remains here the issue of time independence. As mentioned in the beginning, in the present thesis we have retained time independence but relaxed asymptotic flatness. A more realistic situation, however, would necessitate the relaxation of time independence also. This would entail, for instance, the extension of the background from a static to an expanding universe, in accordance with observational data. In his investigations on the cosmological-black hole metrics, Vaidya originally gave a metric which was supposed to incorporate a black hole in the Robertson-Walker universe. However, it

can be shown that the 'event horizon' of this spacetime does not satisfy the defining property of the black hole as being a null surface with the light cone tangential to it. Thus, it fails to be a one-way membrane and as such cannot be called an event horizon at all. Therefore, this spacetime fails to qualify as a candidate for being a black hole. Therefore, arriving at a suitable generalization of the black hole in a time dependent universe is indeed a basic issue that needs to be addressed. Here also, the background-black hole decomposition may be useful in generating new solutions that incorporate black holes in non-flat and non-static backgrounds.

To conclude, we have made a beginning in attempting to understand the nature of black holes in non-flat backgrounds when the standard features of the well-known black holes namely vacuum exterior and asymptotic flatness are given up. As we have pointed out in the above paragraphs, there are several interesting and significant issues that need to be addressed and tackled in order to arrive at a more realistic picture of black holes in non-flat backgrounds. Such investigations, however, must be reserved for the future.

**BLACK HOLES
IN
COSMOLOGICAL BACKGROUNDS**

*A thesis
submitted for the degree of
Doctor of Philosophy
in the Faculty of Science
University of Calicut, India*

B. S. Ramachandra

**Indian Institute of Astrophysics
Bangalore, India**

March 2003

Bibliography

- [1] C.V. Vishveshwara. “ Black Holes in Cosmological Backgrounds”, in *The Universe - Visions and Perspectives*, eds N. Dadhich and A. Kembhavi, (Kluwer Academic, Dordrecht, 2000).
- [2] P.C. Vaidya, *Pramana*, 8, 512(1977).
- [3] K.R. Nayak, M.A.H. MacCallum and C.V. Vishveshwara, “ Black Holes in non-flat backgrounds: The Schwarzschild black hole in the Einstein universe”, *Phys.Rev.D* **63**, 024020(2000).
- [4] Tipler F J, *Nature*, **270**, 500(1977)
- [5] Joshi P S and Narlikar J V, *Pramana*, **18**, 385(1982)
- [6] Hayward S *Black Holes: New horizons*, eprint arXiv: gr-qc/0008071
- [7] Ashtekar 2002, *Class. Quant. Grav* **19** 1195-1225
- [8] McVittie, *Mon. Not. Astron. Soc.*, **93** 325(1933).
- [9] Kramer, Stephani, Herlt, MacCallum, “Exact Solutions of Einstein’s Field Equations”, (Cambridge University Press, Cambridge 1980).
- [10] Andrzej Krasinski, “Inhomogeneous Cosmological models”, (Cambridge University Press, 1998).
- [11] Sussman, R, *J. Math. Phys.***29**, 1177(1988b).
- [12] Einstein and Straus, *Rev. Mod. Phys* **17**, 120(1945).
- [13] Gautreau, *Phys. Rev D***29**, 198(1983).
- [14] Brauer, *Phys. Rev D***45**, 1836(1992).
- [15] A. Chamorro, *Gen. Rel. Grav* **20**, (No 12, 1988).
- [16] C.W. Misner, K.S. Thorne and J.A. Wheeler, “Gravitation”, W.H. Freeman and co, New York, (1973).

- [17] S. Chandrasekhar, "The mathematical theory of black holes" Oxford University press, (1983).
- [18] K. R. Nayak and C. V. Vishveshwara, *GRG*, **29** 291(1997).
- [19] A. R. Prasanna, *Phys. Rev D***43**, 1418(1993).
- [20] B.R. Iyer and C.V. Vishveshwara, *Phys.Rev.D*,**48**, 5706(1993).
- [21] Ramachandra B S and Vishveshwara C V, 2002 *Class.Quant.Grav* **19** 127-141
- [22] K.R. Nayak, B.S. Ramachandra, and C.V. Vishveshwara "The Kerr Black Hole in the Background of the Einstein Universe", Preprint, To be submitted for publication.
- [23] Greene R D, Schucking E L and Vishveshwara C V, 1975 *J.Math.Phys* **16** 153
- [24] Smarr L, 1973 *Phys.Rev.D* **7** 289
- [25] Christodoulou, 1971 *Phys.Rev.Letters* **25** 1596
- [26] 1979 *General Relativity - An Einstein Centenary Survey* ed Hawking S W and Israel W (Cambridge, England)
- [27] Rindler W and Perlick V, 1990 *Gen. Rel. Grav* **22** 9.
- [28] Carter B, 1968 *Commun.Math.Phys* **10** 280-310.
- [29] 1973 *Ann.N.Y. Acad. Sci* **224** 125.
- [30] Floyd R, 1973 *The dynamics of Kerr fields* (PhD thesis, London).
- [31] Walker M and Penrose R, 1970 *Commun.Math.Phys* **18** 265-274.
- [32] Penrose R, 1973 *Ann.N.Y. Acad.Sci.*, **224**, 125-34.
- [33] Samuel J and Vishveshwara C V, *The Killing two form and particle angular momentum in Kerr spacetime* unpublished preprint.
- [34] Faridi A M, 1986 *Gen.Rel.Grav* **18** No 3.
- [35] Carter B, 1973 *Black Holes* ed De Witt C and De Witt B S (Gordon and Breach, New York).
- [36] Chandrasekhar, 1979 *General Relativity - An Einstein Centenary Survey* ed Hawking S W and Israel W (Cambridge, England).
- [37] Carmeli M, 1977 *Group Theory and General Relativity*, McGraw Hill Inc.
- [38] Carmeli M, 1982 *Classical Fields*, John Wiley.
- [39] Flaherty E J, *Hermitian and Kahlerian Geometry in General Relativity* (Springer-Verlag Berlin Heidelberg New York).

- [40] O'Neill B, 1995 *The Geometry of Kerr Black Holes* (A K Peters, Wellesley, Massachusetts).
- [41] Stewart J M, 1993 *Advanced General Relativity* (Cambridge Monographs on Mathematical Physics, Cambridge).
- [42] Penrose R and Rindler W, 1984 *Spinors and Spacetime Vols I, II* (Cambridge Monographs on Mathematical Physics, Cambridge).
- [43] Hughston L P and Sommers P, 1973 *Comm. Math. Phys.*, **32**, 147-52.
- [44] Felice De and Clarke C J S, *Relativity on curved manifolds* Cambridge Monographs on Mathematical Physics, Cambridge.

NIB 3001

TH
523.8875

RAM/B